

# 1. DESCRIZIONE RIDUTTORI

# 1. DESCRIPTION OF GEAR UNITS

# 1. GETRIEBE-BESCHREIBUNG

**EM**  
Versione  
Version  
Ausführung

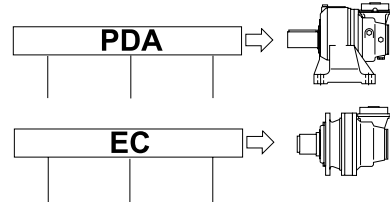
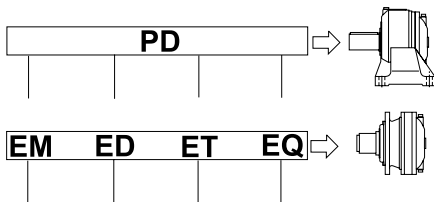

**1**  
Stadi  
Stages  
Ettapes

1 2 3 4

2 3 4

**020**  
Grandezza  
Size  
Größe

010, 010, 010  
020, 020, 020, 020

010, 010, 010  
020, 020, 020

**MR**  
Configurazione uscita  
Output configuration  
Abtriebsanordnung

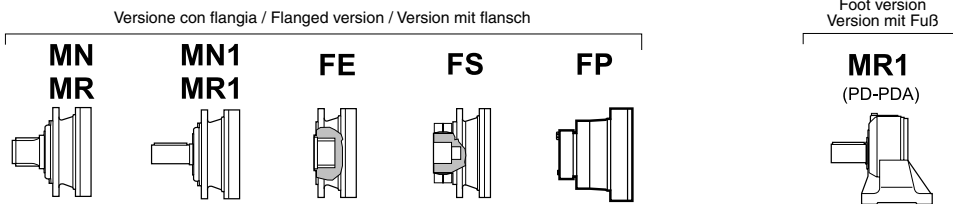

**3.50**  
Rapporto effettivo  
Effective ratio  
Effektives Übersetzungsverhältnis

↓ Vedere tabelle dati tecnici / See data sheet / Siehe Tabelle der technischen Daten ( $i_{eff}$ )

$i_{eff}$	1500			1000			500			$T_{max}$ [Nm]	$P_2$ [kW]
	$n_2$ [rpm]	$T_2$ [Nm]	$P_2$ [kW]	$n_2$ [rpm]	$T_2$ [Nm]	$P_2$ [kW]	$n_2$ [rpm]	$T_2$ [Nm]	$P_2$ [kW]		
<b>EM 1020</b>											
3.08	487	888	45.3	325	1003	34.1	162	1235	21.0	2800	
3.50	429	972	43.6	286	1098	32.9	143	1351	20.2	2800	

**S-45CR1**  
Configurazione entrata  
Input configuration  
Antriebsanordnung

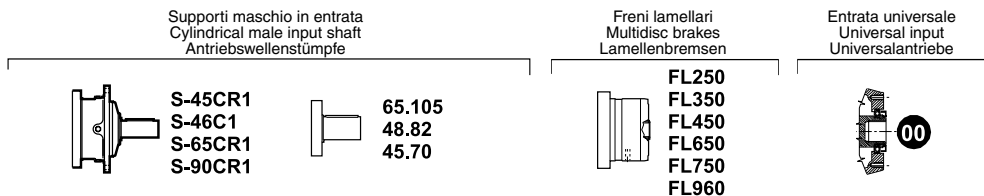

**B3**  
Posizione di montaggio  
Mounting position  
Einbaulage

B3 V5A V6A B3D B3A B3B B3C  
B6 V5B V6B B6C B6A B6B B6D  
B7 V5C V6C B7A B7B B7C B7D  
B8 V5D V6D B8B B8A B8C B8D  
V5  
V6

Esempio di designazione  
Model code example  
Beispiel der kennzeichnung

**EM/1020/MR/3.50/S-45CR1/B3**

# 1. DESCRIPTION DES RÉDUCTEURS

# 1. DESCRIPCIÓN DE LOS REDUCTORES

# 1. DESCRIÇÃO DOS REDUTORES

**EM**  
Version  
Versión  
Versão

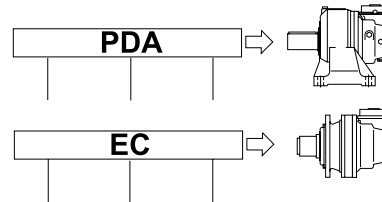
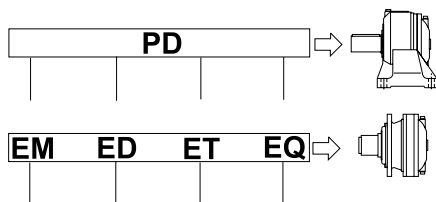

**1**  
Étapes  
Etapas  
Estágio

1 2 3 4

2 3 4

**020**  
Grandeur  
Tamaño  
Tamanho

010, 010, 010  
020, 020, 020, 020

010, 010, 010  
020, 020, 020

**MR**  
Configuration sortie  
Configuración de la salida  
Configuração de saída

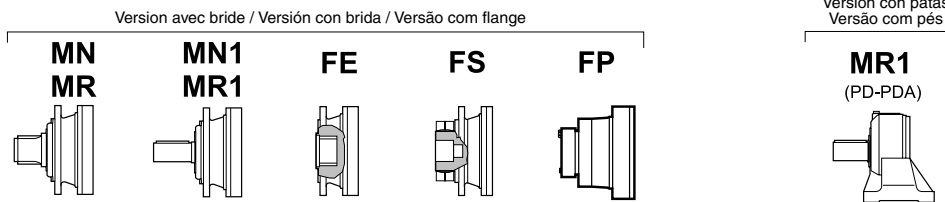

**3.50**  
Rapport effectif  
Relación efectiva  
Relação efetiva

↓ Voir tableau des caractéristiques techniques / Véase la tabla de datos técnicos / Consultar a tabla de dados técnicos (i<sub>eff</sub>)

i <sub>eff</sub>	1500			1000			500			T <sub>2max</sub> [Nm]	P <sub>2</sub> [kW]
	n <sub>2</sub> [rpm]	T <sub>2</sub> [Nm]	P <sub>2</sub> [kW]	n <sub>2</sub> [rpm]	T <sub>2</sub> [Nm]	P <sub>2</sub> [kW]	n <sub>2</sub> [rpm]	T <sub>2</sub> [Nm]	P <sub>2</sub> [kW]		
<b>EM 1020</b>											
3.08	487	888	45.3	325	1003	34.1	162	1235	21.0	2800	
3.50	429	972	43.6	286	1098	32.9	143	1351	20.2	2800	

**S-45CR1**  
Configuration entrée  
Configuración de la entrada  
Configuração de entrada

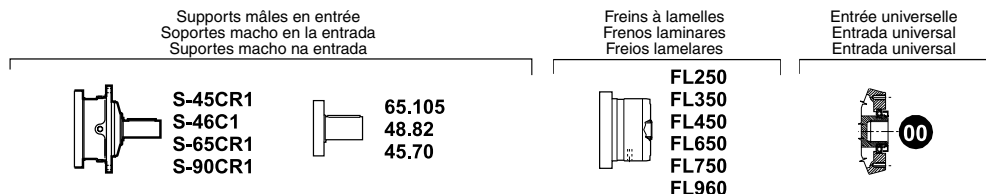

**B3**  
Position de montage  
Posición de montaje  
Posição de montagem

B3 V5A V6A B3D B3A B3B B3C  
B6 V5B V6B B6C B6A B6B B6D  
B7 V5C V6C B7A B7B B7C B7D  
B8 V5D V6D B8B B8A B8C B8D  
V5  
V6

Exemple de désignation / Ejemplo de identificación / Exemplo de designação  
**EM/1020/MR/3.50/S-45CR1/B3**

## 2. DESCRIZIONI TECNICHE

### Rapporto di riduzione $i_{eff}$

Rappresenta la relazione fra la velocità in ingresso  $n_1$  ed uscita del riduttore  $n_2$ . La modularità della gamma proposta da Brevini Riduttori permette la disponibilità di altri rapporti oltre a quelli indicati: consultare Brevini Riduttori per la eventuale disponibilità di ulteriori rapporti.

### Coppia in uscita $T_2$ [Nm]

Valore della coppia in uscita riduttore riferita ad una durata di 10000 ore di funzionamento, calcolata secondo I.S.O. (D.P. 6336).

Tale valore (fattore di applicazione uguale ad 1) è indicato sia per i riduttori con versione in linea che angolari in relazione alle diverse velocità in ingresso.

### Coppia massima $T_{2MAX}$ [Nm]

Coppia massima d'uscita ammissibile, come punta o per brevi durate. Per azionamenti che comportano un elevato numero di avviamenti o inversioni, anche la coppia massima di impiego deve essere opportunamente limitata in relazione alla resistenza degli ingranaggi o degli alberi.

### Coppia nominale $T_N$ [Nm]

È la coppia convenzionale che caratterizza la grandezza del riduttore. Trova corrispondenza nella coppia limite secondo I.S.O. (D.P. 6336) del rapporto più forte di ogni grandezza.

### Potenza in uscita $P_2$ [kW]

Combinazione del valore di coppia relativo ad una durata di 10000 h alla relativa velocità in uscita riduttore. Per le versioni angolari i suddetti valori fanno riferimento ad una versione con ingresso universale. Nei casi in cui il valore della potenza nominale nell'applicazione considerata superi il valore della potenza termica del riduttore in oggetto, occorre prevedere un apposito circuito ausiliario di raffreddamento dell'olio.

### Potenza termica $P_T$ [kW]

Potenza che può essere trasmessa in continuo dal riduttore, in determinate condizioni di funzionamento, relativamente alle massime temperature ammissibili per il riduttore. Vedere il capitolo: Potenza termica.

### Velocità in ingresso $n_1$ [ $\text{min}^{-1}$ ]

I valori di velocità in ingresso indicati nel catalogo sono tre per coprire la maggior parte delle applicazioni del settore industriale.

## 2. TECHNICAL DESCRIPTIONS

### Reduction ratio $i_{eff}$

It represents the ratio between gear unit input and output speed.

The modularity of the Brevini Riduttori range offers the availability of other ratios in addition to those given: consult Brevini Riduttori for the availability of further ratios.

### Output torque $T_2$ [Nm]

Gear unit output torque referred to 10000 hours of operation, calculated according to I.S.O. (D.P. 6336).

This value (application factor equal to 1) is given for gear units with inline and right-angle versions according to the different input speeds.

### Max. torque $T_{2MAX}$ [Nm]

Max. permissible output torque, as peak or for short periods.

For drives involving a high number of starts or reversals, also the max. operational torque must be opportunely limited according to the fatigue resistance of the gears or shafts.

### Nominal torque $T_N$ [Nm]

The conventional torque characterizing the size of the gear unit.

It corresponds to the limit torque according to I.S.O. (D.P. 6336) of the strongest ratio of each size.

### Nominal power $P_2$ [kW]

A combination of the torque value relevant to a duration of 10000 h at the relative gear unit output speed.

For right-angle units the above values refer to a version with universal input.

In those cases when the nominal power value in the application considered exceeds the relevant gear unit thermal rating, a special auxiliary oil cooling circuit must be provided.

### Thermal rating $P_T$ [kW]

The power that can be transmitted continuously by the gear unit, in given operating conditions, relevant to the max. permissible temperatures for the gear unit. See chapter: Thermal rating.

### Input speed $n_1$ [ $\text{min}^{-1}$ ]

The catalogue gives three input speed values to cover the majority of applications in the industrial sector.

## 2. TECHNISCHE BESCHREIBUNGEN

### Übersetzungsverhältnis $i_{eff}$

Stellt das Verhältnis zwischen Antriebsdrehzahl  $n_1$  und Abtriebsdrehzahl  $n_2$  dar. Das Baukastensystem der Brevini Riduttori Getriebe bietet neben den aufgeführten weitere Übersetzungsverhältnisse an: wenden Sie sich an Brevini Riduttori für Auskünfte über weitere verfügbare Übersetzungsverhältnisse.

### Abtriebsdrehzahl $T_2$ [Nm]

Wert der Abtriebsdrehzahl des Getriebes bezogen auf eine Dauer von 10000 Betriebsstunden, berechnet laut I.S.O. (D.P. 6336).

Dieser Wert (Anwendungsfaktor gleich 1) gilt sowohl für In-Line- wie auch für die Winkelgetriebe entsprechend den verschiedenen Antriebsdrehzahlen.

### Maximales Drehmoment $T_{2MAX}$ [Nm]

Maximal zulässiges Abtriebsdrehmoment, sowohl als Spitze wie auch für kurze Dauer. Bei Antrieben mit einer hohen Anzahl von Starts oder Umsteuerungen muss auch das maximale Betriebsdrehmoment entsprechend der Ermüdungsbeständigkeit der Zahnräder oder Wellen begrenzt werden.

### Nenn Drehmoment $T_N$ [Nm]

Das konventionelle Drehmoment, das die Getriebegröße bezeichnet.

Es entspricht dem Grenzdrehmoment laut I.S.O. (D.P. 6336) des höchsten Drehmomentverhältnisses jeder Größe.

### Abtriebsleistung $P_2$ [kW]

Kombination des Drehmomentwerts für eine Dauer von 10000 Stunden mit der Abtriebsdrehzahl des Getriebes. Bei Winkelgetrieben beziehen sich die Werte auf eine Ausführung mit Universalantrieb. Bei allen Fällen, in denen die Nennleistung bei der in Betracht gezogenen Anwendung den Wert der Wärmeleistung des Getriebes übertrifft, muss ein geeignetes zusätzliches Kühlsystem installiert werden.

### Wärmeleistung $P_T$ [kW]

Leistung, die kontinuierlich vom Getriebe unter bestimmten Betriebsbedingungen abgegeben werden kann in Bezug auf die für das Getriebe zulässigen Höchsttemperaturen. Siehe Kapitel: Wärmeleistung.

### Antriebsdrehzahl $n_1$ [ $\text{min}^{-1}$ ]

Die drei im Katalog angegebenen Werte der Antriebsdrehzahlen decken den größten Teil der Anwendungen des Industriebereichs ab.

## 2. DESCRIPTIONS TECHNIQUES

### Rapport de réduction $i_{\text{eff}}$

Il représente la relation entre la vitesse en entrée  $n_1$  et la vitesse en sortie du réducteur  $n_2$ . La modularité de la gamme proposée par Brevini Riduttori permet de disposer d'autres rapports en plus de ceux indiqués: consulter Brevini Riduttori pour l'éventuelle disponibilité d'autres rapports.

### Couple de sortie $T_2$ [Nm]

La valeur du couple de sortie se réfère à une durée de 10000 heures de fonctionnement, calculée selon I.S.O. (D.P. 6336).

Cette valeur (facteur d'application égal à 1) convient tant pour les réducteurs version en ligne que pour ceux angulaires en rapport avec les différentes vitesses en entrée.

### Couple maximum $T_{2\text{MAX}}$ [Nm]

Couple maximum de sortie admissible, comme crête ou pour de courtes durées. Pour des entraînements qui comportent un nombre élevé de démarrages ou d'inversions, même le couple maximum doit être convenablement limité par rapport à la résistance des engrenages ou des arbres.

### Couple nominal $T_N$ [Nm]

C'est le couple conventionnel qui caractérise la grandeur du réducteur. Son correspondant est le couple limite selon I.S.O. (D.P. 6336) du rapport le plus élevé de chaque grandeur.

### Puissance de sortie $P_2$ [kW]

Combinaison de la valeur de couple pour une durée de 10000 heures avec la vitesse de sortie du réducteur correspondant. Pour les versions angulaires, les valeurs sus-citées se réfèrent à une version avec prédisposition d'entrée universelle. Si la valeur de la puissance nominale de l'application concernée dépasse la valeur de la puissance thermique du réducteur en question, il faudra alors prévoir un circuit auxiliaire de refroidissement de l'huile.

### Puissance thermique $P_T$ [kW]

Puissance qui peut être transmise en continu par le réducteur, dans des conditions de fonctionnement données, relativement aux températures maximales admissibles pour le réducteur. Voir chapitre: Puissance thermique.

### Vitesse d'entrée $n_1$ [ $\text{min}^{-1}$ ]

Les valeurs de vitesse d'entrée indiquées dans le catalogue sont au nombre de trois et permettent une adaptation optimale à la plupart des applications du secteur industriel.

## 2. DESCRIPCIONES TÉCNICAS

### Relación de reducción $i_{\text{er}}$

Es la relación entre las velocidades de entrada  $n_1$  y de salida del reductor  $n_2$ . La gama ofrece muchas otras relaciones además de las indicadas: contacte con Brevini Riduttori para obtener más información.

### Par de salida $T_2$ [Nm]

Es el par de salida del reductor para 10000 horas de duración calculado según ISO (D.P. 6336).

El valor (factor de aplicación=1) se indica tanto para los reductores en línea como para los angulares en relación con distintas velocidades de entrada.

### Par máximo $T_{2\text{MAX}}$ [Nm]

Es el máximo par de salida admisible, como pico o en intervalos cortos. Si el accionamiento realiza arranques o inversiones frecuentes es preciso limitarlo de acuerdo con la resistencia de los engranajes o de los ejes.

### Par nominal $T_N$ [Nm]

Es el par convencional que corresponde al tamaño del reductor. Coincide con el par límite ISO (D.P. 6336) de la relación más grande de cada tamaño.

### Potencia de salida $P_2$ [kW]

Combina el par para 10000 horas de duración con la velocidad de salida del reductor. Los valores arriba indicados se refieren a una versión angular con entrada universal. Cuando la potencia nominal de la aplicación es mayor que la potencia térmica del reductor es preciso instalar un circuito auxiliar para enfriar el aceite.

### Potencia térmica $P_T$ [kW]

Potencia que el reductor puede transmitir de manera continua en determinadas condiciones de funcionamiento para la máxima temperatura admitida por el mismo. Véase el capítulo: Potencia térmica.

### Velocidad de entrada $n_1$ [ $\text{min}^{-1}$ ]

Los tres valores de velocidad que aparecen en el catálogo cubren la mayor parte de las aplicaciones industriales.

## 2. DESCRIÇÕES TÉCNICAS

### Relação de redução $i_{\text{eff}}$

Representa a relação entre a velocidade de entrada  $n_1$  e de saída do reductor  $n_2$ . A modularidade da gama proposta pela Brevini Riduttori permite a disponibilidade de outras relações além daquelas indicadas: consultar a Brevini Riduttori para obter a eventual disponibilidade de relações adicionais.

### Torque de saída $T_2$ [Nm]

Valor do torque de saída do reductor com referência a uma duração de 10000 horas de funcionamento, calculada conforme a ISO (D.P. 6336). Esse valor (fator de aplicação igual a 1) é indicado para os reductores nas versões em linha e angulares em relação às diversas velocidades de entrada.

### Torque máximo $T_{2\text{MAX}}$ [Nm]

Torque máximo de saída admissível, como pontas ou para durações curtas. Para acionamentos que implicam um número elevado de partidas ou inversões, também o torque máximo de emprego deve ser limitado de forma adequada em relação à resistência das engrenagens ou dos eixos.

### Torque nominal $T_N$ [Nm]

É o torque convencional que caracteriza o tamanho do reductor. Encontra correspondência com o torque de limite conforme a ISO (D.P. 6336) da maior relação de cada tamanho.

### Potência de saída $P_2$ [kW]

Combinação do valor de torque relativo a uma duração de 10000 horas à velocidade de saída respectiva do reductor. Para as versões angulares, os valores mencionados anteriormente fazem referência a uma versão com entrada universal. Nos casos em que o valor da potência nominal na aplicação considerada ultrapasse o valor da potência térmica do reductor em questão, será necessário prever um circuito auxiliar apropriado de arrefecimento do óleo.

### Potência térmica $P_T$ [kW]

Potência que pode ser transmitida de maneira contínua pelo reductor em determinadas condições de funcionamento em relação às temperaturas máximas admissíveis para o reductor. Consultar o capítulo: Potência térmica.

### Velocidade de entrada $n_1$ [ $\text{min}^{-1}$ ]

Os valores de velocidade de entrada indicados no catálogo são três para cobrir a maior parte das aplicações do setor industrial.

### 3. FATTORE DI SERVIZIO

#### Fattore di applicazione $K_A$

Il fattore di applicazione viene definito dal tipo di motore primo e dal tipo di macchina azionata dal riduttore. Si tratta di un valore empirico stabilito dalle norme attraverso l'esperienza storica delle diverse applicazioni e tiene conto delle variazioni di carico, degli urti della trasmissione e della incertezza relative alla variazione dei parametri che concorrono alla trasmissione della potenza.

L'importanza della macchina azionata è fondamentale nella individuazione del fattore  $K_A$  in quanto i motori utilizzati in combinazione con i riduttori sono normalmente elettrici oppure idraulici e quindi classificati come motorizzazioni ad azionamento uniforme.

Deve essere moltiplicato per la coppia (o la potenza) nominale di funzionamento per ottenere la coppia (o la potenza) di riferimento da confrontare con il valore a catalogo.

Nel caso di motori primi diversi da quelli indicati o nel caso si debbano calcolare durate diverse dalle 10000 ore previste, preghiamo consultare il Servizio Tecnico Commerciale di Brevini Riduttori.

La tabella seguente riporta alcuni valori del fattore di applicazione.

MACCHINA COMANDATA DRIVEN MACHINE ANGETRIEBENE MASCHINE	$K_A$
<b>Agitatori/Mescolatori</b> Agitators/Mixer Rühr-/Mischwerke	
Sostanze liquide Pure liquids Flüssige Stoffe	1
Sostanze semi-liquide Liquid and solids Halbflüssige Stoffe	1.25
Liquido non omogeneo Liquid- variable density Nicht homogene Flüssigkeiten	1.25
<b>Lavorazione pietra ed argilla</b> Clay working machine Stein- und Tonverarbeitung	
Pressa per mattoni Brick press Ziegelpressen	1.75
Macchina per mattonelle Briquette machine Maschinen zur Fliesenherstellung	1.75
Compattatori Compactors Müllverdichter	2
<b>Convogliatori</b> Conveyors-general purpose Förderer	

### 3. SERVICE FACTOR

#### Application factor $K_A$

The application factor is defined by the type of prime mover and the type of machine driven by the gear unit. This is an empirical value fixed by the standards through the historic experience of the various applications and takes into account the variations of load, transmission impacts and uncertainty relative to the variation of parameters involved in the transmission of power.

The importance of the machine driven is essential in identifying the  $K_A$  factor, since the motors used in combination with the gear units are normally electric or hydraulic and therefore classed as uniform drive motorizations.

It must be multiplied by the nominal operating torque (or power) in order to obtain the reference torque (or power) to be compared with the catalogue value.

With prime movers different from those indicated or in the event durations other than the foreseen 10000 hours are to be calculated, please consult the Brevini Riduttori technical commercial assistance service.

The following table gives several application factor values.

MACCHINA COMANDATA DRIVEN MACHINE ANGETRIEBENE MASCHINE	$K_A$
A vite Worm conveyor Schneckenförderer	1
Alimentati uniformemente Uniformly loaded or fed Gleichmäßige Beschickung	1
<b>Per ciclo continuo</b> Heavy duty Dauerbetrieb	
non uniformemente alimentati not uniform fed Ungleichmäßige Beschickung	1.25
con inversione del moto Reciprocating or shaker mit Bewegungsumsteuerung	1.75
<b>Gru</b> Cranes Kran	
<b>Da porto</b> Dry dock Hafenkran	
Sollevamento carico Main Hoist Lastenheben	2.5
Sollevamento ausiliario Auxiliary Hoist Hilfskran	2.5

### 3. BETRIEBSFAKTOR

#### Anwendungsfaktor $K_A$

Der Anwendungsfaktor hängt vom Typ des Primärmotors und der Art der vom Getriebe angetriebenen Maschine ab. Es handelt sich um einen empirischen Wert, der auf den für die verschiedenen Anwendungen durch Erfahrung festgelegte Normen beruht und der die Laständerungen, die Übertragungswucht und die Ungewissheit der Parameteränderung bei der Leistungsübertragung einbezieht. Die angetriebene Maschine ist bei der Festlegung des Faktors  $K_A$  von grundlegender Bedeutung, da es sich bei den mit den Getrieben eingesetzten Motoren meist um Elektro- oder Hydraulikmotoren handelt, die als gleichförmige Antriebsmotoren klassifiziert sind.

Er muss mit dem Nennbetriebsdrehmoment (oder der Nennleistung) multipliziert werden, um das Bezugsdrehmoment (oder die Bezugsleistung) für den Vergleich mit dem Katalogwert zu erhalten.

Bei anderen als den angegebenen Primärmotoren oder bei von 10000 Stunden abweichender Dauer bitten wir Sie, sich an den technischen Kundendienst von Brevini Riduttori zu wenden.

Die folgende Tabelle enthält einige Werte des Anwendungsfaktors.

MACCHINA COMANDATA DRIVEN MACHINE ANGETRIEBENE MASCHINE	$K_A$
Sollevamento braccio Boom Hoist Auslegerhub	2.5
Rotazione braccio Slewing Drive Auslegerdrehung	2.5
Traslazione gru Traction Drive Kranbewegung	3
<b>Container</b> Container Container	
Sollevamento container Main Hoist Container - Heben	3
Sollevamento braccio Boom Hoist Auslegerhub	2
<b>Applicazione industriale</b> Industrial Duty Industrieanwendung	
Sollevamento principale Main Hauptbezeuge	2.5
Sollevamento ausiliario Auxiliary Hilfsbezeuge	2.5

### 3. FACTEUR DE SERVICE

#### Facteur d'application $K_A$

Le facteur d'application est défini par le type de moteur primaire et par le type de machine menée. Il s'agit d'une valeur empirique fixée par les normes par le biais de l'historique des différentes applications et tient compte des variations de charge, des chocs de la transmission et l'incertitude relative à la variation des paramètres qui participent à la transmission de la puissance.

L'importance de la machine menée est fondamentale pour la détermination du facteur  $K_A$  dans la mesure où les moteurs utilisés en combinaison avec les réducteurs sont normalement électriques ou hydrauliques et donc classés comme motorisations à entraînement uniforme. Elle doit être multipliée par le couple (ou la puissance) nominale de fonctionnement pour obtenir le couple (ou la puissance) de référence à comparer avec la valeur du catalogue.

Dans le cas de moteurs primaires différents de ceux indiqués ou dans le cas de calcul de durées différentes des 10000 heures prévues, consulter le service technico-commercial Brevini Riduttori.

Le tableau suivant donne quelques valeurs du facteur d'application.

MACHINES MENÉES MÁQUINA GOBERNADA MÁQUINA COMANDADA	$K_A$
<b>Agitateurs/Mélangeurs</b> <b>Agitadores/Mezcladores</b> <b>Agitadores/Misturadores</b>	
Substances liquides	
Líquidos	1
Substâncias líquidas	
Substances semi-liquides	
Semilíquidos	1.25
Substâncias semilíquidas	
Liquides de densité variable	
Líquidos no homogéneos	1.25
Líquido não homogêneo	
<b>Briques, travail de l'argile</b> <b>Elaboración de piedra y arcilla</b> <b>Processamento de pedra e argila</b>	
Presses à briques	
Prensas para ladrillos	1.75
Prensas para tijolos	
Machines à briquettes	
Máquinas para fabricar azulejos	1.75
Máquina para azulejos	
Compacteurs	
Compactadoras	2
Compactadores	
<b>Convoyeurs</b> <b>Transportadores</b> <b>Transportadores</b>	

### 3. FACTOR DE SERVICIO

#### Factor de aplicación $K_A$

El factor de aplicación está definido por el tipo de motor principal y el tipo de máquina accionado por el reductor. Es un valor empírico que refleja las experiencias realizadas con numerosas aplicaciones. Toma en cuenta las variaciones de carga, los choques de la transmisión y la incertidumbre acerca de cómo varían los parámetros involucrados en la transmisión de potencia.

El tipo de máquina accionada es fundamental para determinar el factor  $K_A$ , ya que los motores que se combinan con reductores son normalmente eléctricos o hidráulicos y se considera que el accionamiento es uniforme.

El factor de aplicación se multiplica por el par (o por la potencia) nominal de funcionamiento para obtener un par (o una potencia) de referencia que se compara con el valor del catálogo.

Si los motores principales son diferentes de los indicados o la duración prevista no es 10000 horas, se ruega consultar con el servicio técnico de Brevini Riduttori.

La tabla indica algunos valores para el factor de aplicación.

MACHINES MENÉES MÁQUINA GOBERNADA MÁQUINA COMANDADA	$K_A$
À vis	
de tornillo	1
De parafuso	
Uniformément alimentés	
Alimentación uniforme	1
Alimentados uniformemente	
<b>Pour cycle continu</b> <b>Para ciclo continuo</b> <b>Para ciclo contínuo</b>	
non uniformément alimentés	
Alimentación no uniforme	1.25
alimentados não uniformemente	
réversibles	
con inversión del movimiento	1.75
com inversão de movimento	
<b>Grue</b> <b>Grúas</b> <b>Guindaste</b>	
<b>Portuaire</b> <b>para puertos</b> <b>De porto</b>	
Levage charge	
Elevación de la carga.5	2.5
Içamento de carga	
Levage auxiliaire	
Elevación auxiliar.5	2.5
Içamento auxiliar	

### 3. FATOR DE SERVIÇO

#### Fator de aplicação $K_A$

O fator de aplicação é definido pelo tipo de máquina motriz e pelo tipo de máquina acionada pelo reductor. Trata-se de um valor empírico estabelecido pelas normas através da experiência histórica das diversas aplicações e leva em consideração as variações de carga, os impactos da transmissão e a incerteza relativas à variação dos parâmetros que concorrem para a transmissão da potência. A importância da máquina acionada é fundamental na determinação do fator  $K_A$ , porque os motores utilizados em combinação com os reductores normalmente são elétricos ou hidráulicos e, portanto, são classificados como motorizações com acionamento uniforme. Deve ser multiplicado pelo torque (ou a potência) nominal de funcionamento para obter o torque (ou a potência) de referência a ser comparado com o valor do catálogo.

No caso de máquinas motrizes diferentes daquelas indicadas ou caso seja necessário calcular durações diferentes das 10000 horas previstas, consultar o Serviço Técnico Comercial da Brevini Riduttori.

A tabela a seguir indica alguns valores do fator de aplicação.

MACHINES MENÉES MÁQUINA GOBERNADA MÁQUINA COMANDADA	$K_A$
Levage bras	
Elevación del brazo.5	2.5
Içamento braço	
Rotation bras	
Rotación del brazo.5	2.5
Rotação braço	
Translation grue	
Traslación de la grúa 3	3
Translação guindaste	
<b>Conteneurs</b> <b>Container</b> <b>Contêiner</b>	
Levage conteneurs	
Elevación de un container 3	3
Içamento de contêiner	
Levage bras	
Elevación del brazo	2
Içamento braço	
<b>Application industrielle</b> <b>Aplicaciones industriales</b> <b>Aplicação industrial</b>	
Levage principal	
Elevación principal.5	2.5
Içamento principal	
Levage auxiliaire	
Elevación auxiliar.5	2.5
Içamento auxiliar	

MACCHINA COMANDATA DRIVEN MACHINE ANGETRIEBENE MASCHINE	K <sub>A</sub>	MACCHINA COMANDATA DRIVEN MACHINE ANGETRIEBENE MASCHINE	K <sub>A</sub>	MACCHINA COMANDATA DRIVEN MACHINE ANGETRIEBENE MASCHINE	K <sub>A</sub>
Bridge		Ciclo continuo- a vite		Lavorazione tronco	
Bridge	3	Continuous screw operation	1.75	Main log	1.75
Brückenkran		Kontinuierlicher Schneckenbetrieb		Verarbeitung von Baumstämmen	
Movimentazione carrello		Ciclo intermittente- a vite		Piallatrice	
Trolley Travel	3	Intermittent screw operation	1.75	Slab	1.75
Laufkatzen		Schnecken - Aussetzbetrieb		Hobelmaschine	
<b>Trituratori</b>		<b>Alimentatori</b>		Trasbordatore	
<b>Crusher</b>		<b>Feeders</b>		Transfer	1.25
<b>Schredderanlagen</b>		<b>Beschickungseinrichtungen</b>		Umlader	
Pietre e metalli		A piastre		Scortecciatrice	
Stone or ore	1.75	Apron	1.25	Debarking drums	1.75
Steine und Metall		Platten		Rindenschälmaschine	
<b>Draghe</b>		A nastro		Alimentazione piallatrice	
<b>Dredges</b>		Belt	1.25	Planer feed	1.25
<b>Nassbagger</b>		Band		Hobelmaschinen - Zuführer	
Avvolgicavo		A vite		Trasbordatore a catena	
Cable reel	1.25	Screw	1.25	Transfers -chain	1.5
Kabelaufwickler		Schnecken		Kettenumlader	
Convogliatore		<b>Industria alimentare</b>		<b>Lavorazione metalli</b>	
Conveyors	1.25	<b>Food industry</b>		<b>Metal mills</b>	
Förderer		<b>Lebensmittelindustrie</b>		<b>Metallverarbeitung</b>	
Testa portafresa		Lavorazione cereali		Ribaltatori	
Cutter head drives	2	Cereal cooker	1	Reversing	2
Fräskopf		Getreideverarbeitung		Kipper	
Setacci		mescolatori per pasta		Spingitore lingotti	
Screen drives	1.75	Dough mixer	1.25	Slab pushers	1.5
Siebe		Teigmischer		Barrenandrücker	
Convogliatore a tazze		Triturazione carne		Tranciatrici	
Stackers	1.25	Meat grinders	1.25	Shears	2
Eimerförderer		Fleischmühlen		Schneidpressen	
Verricelli di manovra		<b>Sollevatori/Elevatori</b>		Trafila	
Winches	1.25	<b>Hoists</b>		Wire drawing	1.25
Winden		<b>Hebewerke</b>		Drahtziehmaschine	
<b>Elevatori</b>		Ciclo continuo		Aspo	
<b>Elevators</b>		Heavy duty	1.75	Wire Winding machine	1.5
<b>Hebewerke</b>		Dauerbetrieb		Haspel	
A tazze		Ciclo intermittente		<b>Lavorazione nastri</b>	
Bucket	1.25	Medium duty	1.25	<b>Metal strip processing machinery</b>	
Becherwerke		Aussetzbetrieb		<b>Bearbeitung von Metallbändern</b>	
Scala mobile		Sollevamento cassonetto		Nastratrici	
Escalators	1	Skip hoist	1.25	Bridles 1.25	
Rolltreppe		Kippvorrichtungen		Bandwickler	
<b>Estrusori</b>		<b>Macchine di lavaggio</b>		Avvolgitrice. Svolgitrice	
<b>Extruders</b>		<b>Laundry</b>		Coilers & uncoilers	1
<b>Strangpressen</b>		<b>Wäschereien</b>		Aufwickler. Abwickler	
In generale		Bottali		Rifilatrice	
General	1.5	Tumblers	1.25	Edge trimmers	1.25
Allgemein		Tumbler		Beschneidemaschine	
<b>Plastica</b>		Lavatrice		Spianatrice	
<b>Plastics</b>		Washers	1.5	Flatteners	1.25
<b>Kunststoff</b>		Waschmaschinen		Planiermaschine	
A velocità variabile		<b>Macchine per legno</b>		Regolazione cilindri	
Variable speed drive	1.5	<b>Lumber industry</b>		Pinch rolls	1.25
Mit regelbarer Drehzahl		<b>Holzbearbeitungsmaschinen</b>		Andrückrollen	
A velocità fissa		Convogliatori		Trattamento rottami	
Fixed speed drive	1.75	Conveyors-burner	1.25	Scrap choppers	1.25
Mit fester Drehzahl		Förderer		Abfallschere	
<b>Gomma</b>		A ciclo continuo		Tranciatrici	
<b>Rubber</b>		Main or heavy duty	1.5	Shears	2
<b>Gummi</b>		Dauerbetrieb		Schneidpressen	

<b>MACHINES MENÉES MÁQUINA GOBERNADA MÁQUINA COMANDADA</b>	<b>K<sub>A</sub></b>	<b>MACHINES MENÉES MÁQUINA GOBERNADA MÁQUINA COMANDADA</b>	<b>K<sub>A</sub></b>	<b>MACHINES MENÉES MÁQUINA GOBERNADA MÁQUINA COMANDADA</b>	<b>K<sub>A</sub></b>
Ponts		Cycle continu- à vis		Machines à travailler les grumes	
Puente 3	<b>3</b>	Ciclo continuo - de tornillo	<b>1.75</b>	Aserraderos	<b>1.75</b>
Ponte rolante		Ciclo contínuo - de parafuso		Processamento de tronco	
Manutention chariot		Cycle intermittent- à vis		Raboteuses	
Desplazamiento del carro 3	<b>3</b>	Ciclo intermitente - de tornillo	<b>1.75</b>	Cepilladoras	<b>1.75</b>
Movimentação carrinho		Ciclo intermitente – de parafuso		Plaina	
<b>Broyeurs</b>		<b>Alimentateurs</b>		Transferts	
<b>Trituradoras</b>		<b>Alimentadores</b>		Transbordadores	<b>1.25</b>
<b>Trituradores</b>		<b>Alimentadores</b>		Transbordador	
Cailloux et métaux		À plateaux		Écorceuses	
Piedras y metales	<b>1.75</b>	Planchas	<b>1.25</b>	Descortezadoras	<b>1.75</b>
Pedras e metais		De placas		Descascador	
<b>Dragues</b>		Bande transporteuse		Chaînes d'alimentation des raboteuses	
<b>Dragas</b>		Cinta	<b>1.25</b>	Alimentación de cepilladoras	<b>1.25</b>
<b>Dragas</b>		De fita		Alimentação plaina	
Bobine pour câble		À vis		Transferts à chaîne	
Bobina para el cable	<b>1.25</b>	Tornillo	<b>1.25</b>	Transbordadores de cadena	<b>1.5</b>
Enrolador de cabo		De parafuso		Transbordador a corrente	
Convoyeurs		<b>Industrie alimentaire</b>		<b>Métallurgie</b>	
Transportador	<b>1.25</b>	<b>Industria alimentaria</b>		<b>Mecanizado de metales</b>	
Transportador		<b>Indústria alimentícia</b>		<b>Processamento de metais</b>	
Commande tête d'outil		Traitement des céréales		Retourneurs	
Cabezal portabroca	<b>2</b>	Elaboración de cereales	<b>1</b>	Volquetes	<b>2</b>
Cabeça portafresa		Processamento de cereais		Tombadores	
Tamis		mélangeurs pour pâte à pain		Pousseurs de lingots	
Cedazos	<b>1.75</b>	Mezcladoras para masa	<b>1.25</b>	Empujadores de lingotes	<b>1.5</b>
Peneiradores		misturadores para massas		Empurrador de lingotes	
Convoyeurs à godets		Hâcheurs à viande		Coupeurs ou fendeuses	
Transportador de cangilones	<b>1.25</b>	Trituradoras de carne	<b>1.25</b>	Cizalladoras	<b>2</b>
Transportador de canecas		Trituração de carne		Trançadores	
Treuil de manoeuvre		<b>Élévateurs</b>		Bancs à étirer	
Cabrestantes para maniobras	<b>1.25</b>	<b>Elevadores/Suspensores</b>		Trafiladoras	<b>1.25</b>
Guinchos de manobra		<b>Elevadores</b>		Trefiladora	
<b>Élévateurs</b>		Cycle continu		Dévidoirs	
<b>Elevadores</b>		Ciclo continuo	<b>1.75</b>	Aspos	<b>1.5</b>
<b>Elevadores</b>		Ciclo contínuo		Bobina	
À godets		Cycle intermittent		<b>Rubans</b>	
Cangilones	<b>1.25</b>	Ciclo intermitente	<b>1.25</b>	<b>Fabricación de cintas</b>	
De canecas		Ciclo intermitente		<b>Procesamento de fitas</b>	
Escalators		Ciclo intermitente		Tambours rubaniers ou rubaneuses	
Escaleras mecánicas	<b>1</b>	Levage benne		Encintadoras	
Escada rolante		Elevación de un cajón	<b>1.25</b>	Máquinas para fitas	
<b>Extrudeuses</b>		Içamento de caixa		Enrouleurs Dérouleurs	
<b>Extrusores</b>		<b>Machines à laver</b>		Enrolladoras Desenrolladoras	<b>1</b>
<b>Extrusores</b>		<b>Máquinas lavadoras</b>		Enrolador Desenrolador	
En général		<b>Máquinas de lavagem</b>		Rogneuses	
Todos los tipos	<b>1.5</b>	Tonneaux		Cortadoras	<b>1.25</b>
Em geral		Toneles	<b>1.25</b>	Tosquiador	
<b>Plastique</b>		Tambores		Planeuses	
<b>Plástico</b>		Laveuses		Aplanadoras	<b>1.25</b>
<b>Plástico</b>		Lavadora	<b>1.5</b>	Nivelador	
À vitesse variable		Lavadora		Régulation des tambours	
Velocidad variable	<b>1.5</b>	<b>Machines à bois</b>		Ajuste de los cilindros	<b>1.25</b>
De velocidade variável		<b>Máquinas para madera</b>		Regulação de cilindros	
À vitesse fixe		<b>Máquinas para madeira</b>		Traitement des déchets	
Velocidad fija	<b>1.75</b>	Convoyeurs		Tratamiento de la chatarra	<b>1.25</b>
De velocidade fixa		Transportadores	<b>1.25</b>	Tratamento de sucata	
<b>Caoutchouc</b>		Transportadores		Trancheuses	
<b>Goma</b>		à cycle continu		Cizalladoras	<b>2</b>
<b>Borracha</b>		De ciclo continuo	<b>1.5</b>	Trançadores	
		De ciclo contínuo			



MACCHINA COMANDATA DRIVEN MACHINE ANGETRIEBENE MASCHINE	K <sub>A</sub>	MACCHINA COMANDATA DRIVEN MACHINE ANGETRIEBENE MASCHINE	K <sub>A</sub>	MACCHINA COMANDATA DRIVEN MACHINE ANGETRIEBENE MASCHINE	K <sub>A</sub>
Tranciatrici a striscia Slitters Streifenscheren	1.25	Truccioli Chip Späne	1.5	Alimentatori sostanze chimiche Chemical feeders Chemikalien - Beschicker	1.25
<b>Lavorazione cemento Mills. rotary type Zementverarbeitung</b>		Rotativi Rotary Drehend	1.5	Schermi disidratatori Dewatering screens Entwässerungsfilter	1.5
Forno per cemento Cement Kilns Zementofen	1.5	Vibranti Vibrating Rüttler	2	Separatore parti pesanti Scum breakers Abscheider schwerer Partikel	1.5
Essicatoi Dryers & coolers Trockenofen	1.5	Size press Size press Size Press	1.25	Mescolatore Slow or rapid mixers Mischer	1.5
Mescolatori Mixer concrete Misch-/Knetmaschinen	1.25	Super calender Super calender Super-Kalender	1.25	Collettore dei fanghi Sludge collectors Schlamm-sammler	1.25
<b>Lavorazione carta Paper mills Papierherstellung</b>		Ispestitrice (motore in a.c.) Thickener (AC motor) Eindickungsmaschine (GS-Motor)	1.5	Ispestitore Thickeners Eindicker	1.5
Agitatori, mescolatori Agitator (mixer) Rührwerke Mischer	1.5	Ispestitrice (motore in corrente cont.) Thickener (DC motor) Eindickungsmaschine (WS-Motor)	1.25	Filtri a vuoto Vacuum filters Vakuumfilter	1.5
Agitatori sostanze liquide Agitator for pure liquors Rührwerke für flüssige Stoffe	1.25	Lavatrice (motore in c.a.) Washer ( AC motor) Waschmaschine (GS-Motor)	1.5	<b>Schermi Screens Schirme</b>	
Calandre Calender Kalender	1.25	Lavatrice (DC motore in corr. cont.) Washer (DC motor) Waschmaschine (WS-Motor)	1.25	Lavaggio ad aria Air washing Luftwaschen	1
Sminuzzatrice Chipper Brechanlage	2	<b>Lavorazione plastica Plastic industry Kunststoffverarbeitung</b>		Rotativi per ghiaia Rotary-stone or gravel Kiesmaschinen	1.25
Alimentatore sminuzzatrice Chip feeder Beschicker der Brechanlage	1.5	Mescolatore per lotti Batch mixers Chargenmischer	1.75	<b>Lavorazione zucchero Sugar industry Zuckerindustrie</b>	
Rulli di lucidatura Coating rolls Polierwalzen	1.25	Mescolatore a ciclo continuo Continuous mixers HD - Mischer	1.5	Affettatrice barbabietole Beet slicer Zuckerrübenschnitzelmaschine	2
<b>Convogliatori Conveyor Förderer</b>		Calandre Calenders Kalender	1.5	Frantoi per canna Cane knives Zuckerrohrmühle	1.5
Truciolli, corteccia Chip, bark, chemical Späne Rinde	1.25	<b>Lavorazione gomma Rubber industry Gummiverarbeitung</b>		Trituratori Crushers Zerkleinerer	1.5
Tronchi Log (including slab) Baumstämme	2	Mescolatore per lotti Batch mixers Chargenmischer	1.75	Macinatori Mills (low speed end) Mahlmaschinen	1.75
<b>Essicatoi Dryers Trockenofen</b>		Mescolatore a ciclo continuo Continuous mixers HD - Mischer	1.5	<b>Lavorazione tessuti Textile industry Textilindustrie</b>	
Tagliatrice Paper machine Schneidemaschine	1.25	Calandre Calenders Kalender	1.5	Impianti di dosatura batchers Dosieranlagen	1.25
Convogliatori Conveyor type Förderer	1.5	Riscaldamento sabbia Sand muller Formsandaufbereiter	1.25	Calandre calenders Kalender	1.25
Estrusori Extruder Strangpressen	1.5	<b>Trattamento acque Sewage disposal equipment Wasseraufbereitung</b>		Essicatoi Dryers Trockenofen	1.25
<b>Vagli Screen Siebanlagen</b>		Schermo a barre Bar screens Stabsiebrost	1.25		

MACHINES MENÉES MÁQUINA GOBERNADA MÁQUINA COMANDADA	K <sub>A</sub>	MACHINES MENÉES MÁQUINA GOBERNADA MÁQUINA COMANDADA	K <sub>A</sub>	MACHINES MENÉES MÁQUINA GOBERNADA MÁQUINA COMANDADA	K <sub>A</sub>
Trancheuses à bande		Copeaux		Alimentateurs substances chimiques	
Cizalladoras de cintas	1.25	Virutas	1.5	Alimentadores de sustancias químicas	1.25
Trançadores de faixa		Cavacos		Alimentadores de produtos químicos	
<b>Traitement du ciment</b>		Rotatifs		Écrans déshydrateurs	
<b>Producción de cemento</b>		Giratorios	1.5	Pantallas deshidratadoras	1.5
<b>Processamento de cimento</b>		Rotativos		Telas desidratadores	
Fours de cimenterie		Vibrants		Séparateurs parties lourdes	
Hornos para cemento	1.5	Vibradores	2	Separadores de partes pesadas	1.5
Forno para cimento		Vibração		Separador partes pesadas	
Séchoirs		Size press		Mélangeurs	
Secadores	1.5	Size press	1.25	Mezcladoras	1.5
Secadores		Size press		Misturador	
Mélangeurs		Super calendar		Collecteurs de boues	
Mezcladoras	1.25	Super calendar	1.25	Colectores para lodos	1.25
Misturadores		Super calendar		Coletor de lama	
<b>Papier</b>		Épaisseurs (moteur à c.a.)		Épaisseurs	
<b>Industria papelera</b>		Espesadores (motor de corriente alternada)	1.5	Espesadores	1.5
<b>Processamento de papel</b>		Espessador (motor CA)		Espessador	
Agitateurs mélangeurs		Épaisseurs (moteur à courant continu)		Filtres à vide	
Agitadores Mezcladoras	1.5	Espesadores (motor de corriente continua)	1.25	Filtros en vacío	1.5
Agitadores Misturadores		Espessador (motor CC)		Filtros a vácuo	
Agitateurs de liquides		Laveurs (moteur à c.a.)		<b>Écrans</b>	
Agitadores para líquidos	1.25	Lavadora (motor de corriente alternada)	1.5	<b>Pantallas</b>	
Agitadores de substâncias líquidas		Lavadora (motor CA)		<b>Telas</b>	
Calandres		Laveurs (CC moteur à cour. cont.)		Lavage à air	
Calandras	1.25	Lavadora (motor de corriente continua)	1.25	Limpieza con aire	1
Calandras		Lavadora (motor CC)		Lavagem a ar	
Déchiqueteuses		<b>Plastique</b>		Rotatifs pour gravier	
Trituradoras	2	<b>Industria del plástico</b>		Giratorias para grava	1.25
Triturador		<b>Processamento de plástico</b>		Rotativos para cascalho	
Chaînes d'alimentation des déchiqueteuses		Mélangeurs pour lots		<b>Sucre</b>	
Alimentadores de trituradoras	1.5	Mezcladora por lotes	1.75	<b>Industria azucarera</b>	
Alimentador triturador		Misturador por lotes		<b>Processamento de açúcar</b>	
Glaceuses		Mélangeurs à cycle continu		Coupeur de betteraves	
Rodillos para pulir	1.25	Mezcladora de ciclo continuo	1.5	Cortadoras de remolachas	2
Rolos de polimento		Misturador de ciclo contínuo		Cortador de beterraba	
<b>Convoyeurs</b>		Calandres		Broyeurs de cannes à sucre	
<b>Transportadores</b>		Calandras	1.5	Molinos de caña	1.5
<b>Transportadores</b>		Calandras		Moendas para cana	
copeaux écorce		<b>Caoutchouc</b>		Broyeurs	
Virutas Corteza	1.25	<b>Industria del caucho</b>		Trituradoras	1.5
Cavacos casca		<b>Processamento de borracha</b>		Trituradores	
Grumes		Mélangeurs pour lots		Moulins	
Troncos	2	Mezcladora por lotes	1.75	Muelas	1.75
Troncos		Misturador por lotes		Moinhos	
<b>Séchoirs</b>		Mélangeurs à cycle continu		<b>Textile</b>	
<b>Secadores</b>		Mezcladora de ciclo continuo	1.5	<b>Industria textil</b>	
<b>Secadores</b>		Misturador de ciclo contínuo		<b>Processamento de tecidos</b>	
Trancheuses		Calandres		Gâcheurs ou bacs de dosage	
Cortadoras	1.25	Calandras	1.5	Sistemas de dosificación	1.25
Cortadora		Calandras		Sistemas de dosagem	
Convoyeurs		Chauffage du sable		Calandres	
Transportadores	1.5	Calentamiento de arena	1.25	Calandras	1.25
Transportadores		Aquecimento de areia		Calandras	
Extrudeuses		<b>Traitement des eaux</b>		Sécheurs	
Extrusores	1.5	<b>Tratamiento de aguas</b>		Secadores	1.25
Extrusores		<b>Tratamento de águas residuais</b>		Secadores	
<b>Cribles ou tamis</b>		Écran à barres			
<b>Tamices</b>		Pantallas de barras	1.25		
<b>Peneiras</b>		Tela de barras			

**Fattore Cs**

Fattore che considera il numero di avviamenti nell'unità di tempo.

**Cs factor**

This factor considers the number of starts in the unit of time.

**Faktor Cs**

Dieser Faktor berücksichtigt die Anzahl der Starts pro Zeiteinheit.

Cs	Avviamenti orari / Starts per hour / Starts pro Stunde			
	1-5	6-25	26-100	101-200
Cs	1	1.05	1.15	1.25

**Temperatura [°C]**

La temperatura di funzionamento ideale è compresa tra 50 °C e 70 °C. Per brevi periodi si possono raggiungere 80 °C. Il sistema migliore per tenere sotto controllo la temperatura è quello di ricorrere ad un sistema ausiliario di scambio termico. Per temperature ambiente molto basse, inferiori a -15 °C, o di funzionamento superiori a 80 °C, si impongono oli adeguati assieme a guarnizioni e materiali speciali che possono essere forniti a richiesta. E' comunque consigliabile consultare il Servizio Tecnico Commerciale Brevini. Vedere il Capitolo: Lubrificazione.

**Temperature [°C]**

The ideal operating temperature is between 50 °C and 70 °C. For short periods 80 °C can be reached. The best system for keeping the temperature under control is to use an auxiliary cooling system. For very low ambient temperatures, below -15 °C, or operating temperatures above 80 °C, the use of suitable oils together with special seals and materials (supplied by request) is required. In any case it is advisable to consult the Brevini technical commercial service. See chapter: Lubrication.

**Temperatur [°C]**

Die ideale Betriebstemperatur liegt im Bereich von 50 °C bis 70 °C. Für kurze Zeiten können 80 °C erreicht werden. Das einfachste System der Temperaturregelung ist die Installation eines zusätzlichen Kühlsystems. Bei sehr niedrigen Umgebungstemperaturen (unter -15 °C) oder bei Betriebstemperaturen über 80 °C sind Spezialschmieröle zusammen mit Spezialdichtungen und Werkstoffen einzusetzen, die auf Anfrage lieferbar sind. Sie sollten sich in solchen Fällen jedoch immer an den technischen Kundendienst Brevini wenden. Siehe Kapitel: Schmierung.

**4. CARICHI RADIALI E ASSIALI**

**Carichi sugli alberi in uscita / entrata Fr [N]**

Per ogni grandezza di riduttore vengono riportati a catalogo i diagrammi dei carichi radiali Fr ammessi sugli alberi in uscita riferiti a  $n_2 \times h = 10^5$  dei cuscinetti. Per durate diverse, i carichi dovranno essere moltiplicati per il coefficiente C (rilevabile dal diagramma 2) il quale non deve eccedere il valore di 1.5 indipendentemente dalla durata.

**4. RADIAL AND AXIAL LOADS**

**Loads on output / input shafts Fr [N]**

The catalogue gives the diagrams of permissible Fr radial loads on the output shafts referred  $n_2 \times h = 10^5$  of bearings. For different durations, the loads must be multiplied by the coefficient C (obtained from diagram 2) which must not exceed the value of 1.5 regardless of the life.

**4. RADIALLAST UND AXIALLAST**

**Lasten auf den Abtriebs- / Antriebswellen Fr [N]**

Der Katalog enthält für jede Getriebegröße die Diagramme der zulässigen Radiallasten Fr auf den Abtriebsachsen bezogen auf  $n_2 \times h = 10^5$  der Lager. Bei unterschiedlicher Dauer sind die Lasten mit dem Koeffizienten C (der dem Diagramm 2 entnommen werden kann) zu multiplizieren, der jedoch unabhängig von der Dauer nicht den Wert 1,5 übersteigen darf.

Esempio:

Example:

Beispiel:

Diagramma Diagram 1 Diagramm



Diagramma Diagram 2 Diagramm



**Facteur Cs**

Facteur tenant compte du nombre de démarrages dans l'unité de temps.

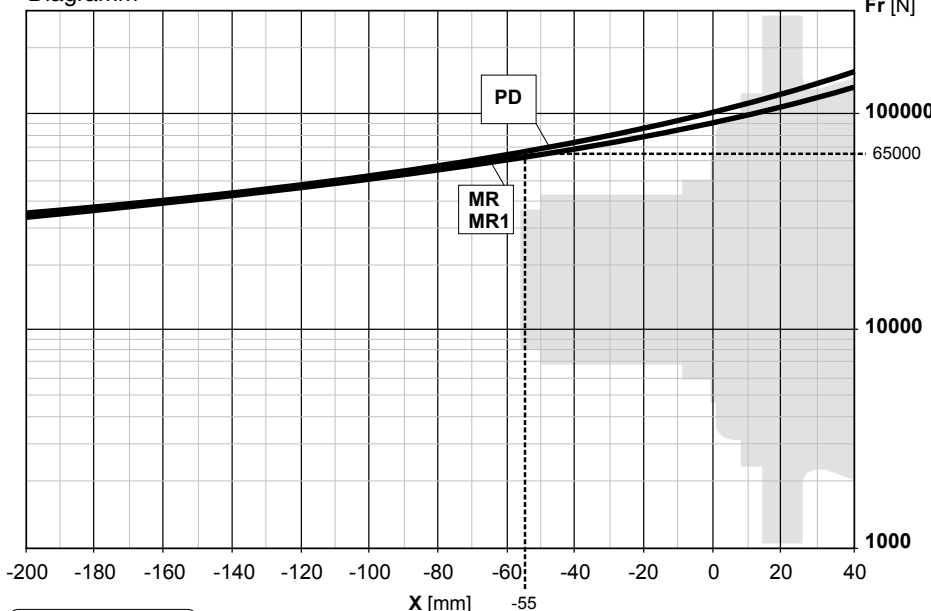
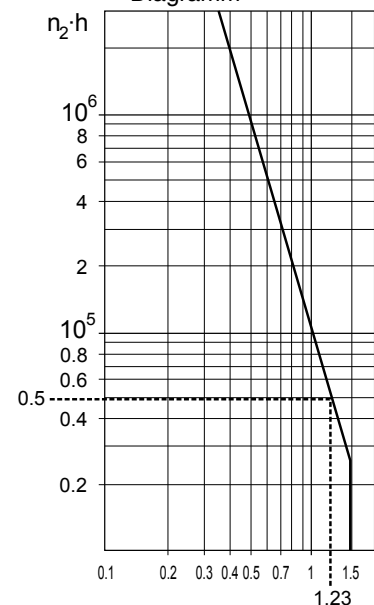
**Factor Cs**

Este factor toma en cuenta el número de arranques por unidad de tiempo.

**Fator Cs**

Fator que considera o número de partidas na unidade de tempo.

Cs	Démarrages par heure / Arranques por hora / Partidas horárias			
	1-5	6-25	26-100	101-200
Cs	1	1.05	1.15	1.25

**Température [°C]**

La température de fonctionnement idéale est comprise entre 50 °C et 70 °C. Pour de courtes périodes de fonctionnement, il est possible d'atteindre une température de 80 °C. Le meilleur système pour surveiller la température est celui d'adopter un système auxiliaire d'échange thermique. Pour des températures ambiantes très basses, inférieures à -15 °C par exemple, ou de fonctionnement supérieures à 80 °C, il est nécessaire d'utiliser des huiles appropriées, ainsi que des joints et matériaux spéciaux qui peuvent être fournis sur demande. Toutefois, il est préférable de prendre contact avec le service technicommercial Brevini. Voir chapitre: Graissage.

**Temperatura [°C]**

La temperatura de funcionamiento ideal está entre 50 y 70 °C. Por periodos breves se puede llegar a 80 °C. El mejor método para regular la temperatura es instalar un sistema auxiliar de intercambio térmico. Si la temperatura ambiente está por debajo de -15 °C o la temperatura de funcionamiento sobrepasa los 80 °C es preciso utilizar aceites, guarniciones y materiales especiales que Brevini Riduttori suministra bajo pedido. Se aconseja contactar con el Servicio Técnico de Brevini. Véase el capítulo: Lubricación.

**Temperatura [°C]**

A temperatura de funcionamento ideal está compreendida entre 50 °C e 70 °C. Por períodos curtos é possível atingir 80 °C. O melhor sistema para manter a temperatura sob controle é recorrer a um sistema auxiliar de troca térmica. Para temperaturas ambientes muito baixas, inferiores a -15 °C, ou temperaturas de funcionamento superiores a 80 °C, são necessários óleos adequados, junto com guarnições e materiais especiais que podem ser fornecidos a pedido. De qualquer modo é aconselhável consultar o Serviço Técnico Comercial da Brevini. Consultar o capítulo: Lubrificação.

**4. CHARGES RADIALES ET AXIALES**

**Charges sur les arbres en sortie / entrée Fr [N]**

Sur le catalogue, pour chaque grandeur de réducteur, sont reportés les diagrammes des charges radiales Fr admissibles sur les arbres de sortie référées à  $n_2 \times h = 10^5$  des roulements. Pour des durées différentes, les charges devront être multipliées par le coefficient C (que l'on peut tirer du diagramme 2) qui ne doit pas dépasser la valeur de 1,5, et ce indépendamment de la durée.

**4. CARGAS RADIALES Y AXIALES**

**Cargas sobre los ejes de salida / entrada Fr [N]**

Para cada tamaño de reductor el catálogo trae los diagramas de las cargas radiales Fr admitidas en los ejes de salida para  $n_2 \times h = 10^5$  de los cojinetes. Si la duración es diferente, las cargas se deben multiplicar por el coeficiente C (tomándolo del diagrama 2). De todas maneras, independientemente de la duración, C no puede ser mayor que 1.5.

**4. CARGAS RADIAIS E AXIAIS**

**Cargas nos eixos de saída/entrada Fr [N]**

Para cada tamanho de reductor são indicados no catálogo os diagramas das cargas radiais Fr admissíveis nos eixos de saída referidos a  $n_2 \times h = 10^5$  dos coxins. Para durações diferentes, as cargas deverão ser multiplicadas pelo coeficiente C (obtido no diagrama 2), o qual não deverá ultrapassar o valor de 1.5, independentemente da duração.

Exemple:

Diagramme 1  
Diagrama 1  
Diagrama 1

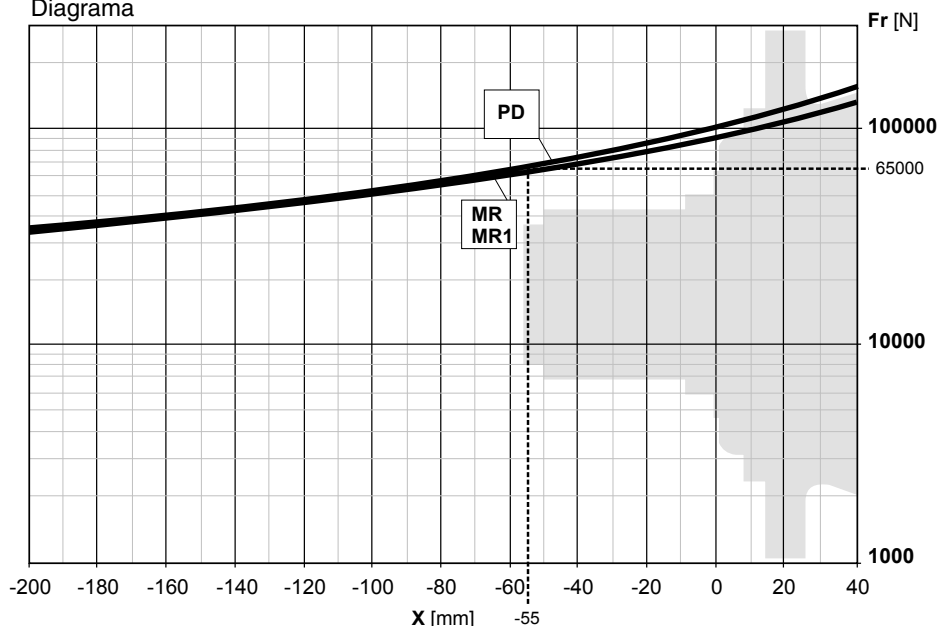

Ejemplo:

Exemplo:

Diagramme 2  
Diagrama 2  
Diagrama 2

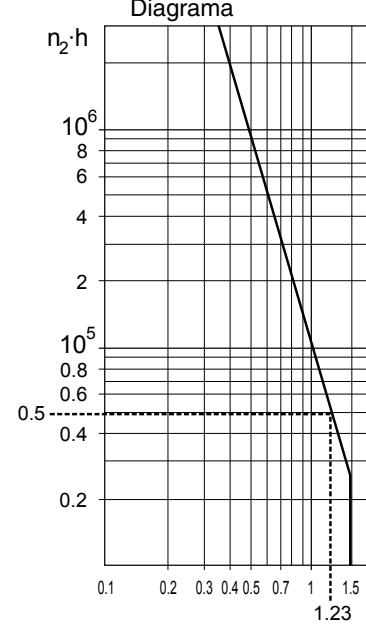

Dati:  
 Riduttore ED2065 MR  
 Carico radiale applicato F = 80 kN  
 Posizione del carico X = - 55 mm  
 Giri uscita  $n_2 = 20 \text{ min}^{-1}$

Data:  
 Gear unit size ED2065 MR  
 Radial load F = 80 kN  
 Load position X = - 55 mm  
 Output speed  $n_2 = 20 \text{ min}^{-1}$

Daten:  
 Getriebe ED2065 MR  
 Angelegte Radiallast F = 80 kN  
 Laststellung X = - 55 mm  
 Abtriebsdrehzahl  $n_2 = 20 \text{ min}^{-1}$

Con i quali calcoliamo:

To be calculated:

Berechnung:

Carico radiale ammissibile  
 Fr = 65 kN (vedi diagramma 1)

Radial load capacity  
 Fr = 65 kN (as per diagram 1)

Zulässige Radiallast  
 Fr = 65 kN (siehe Diagramm 1)

$$c = \frac{F}{F_r} = 1.23 \quad (\text{vedi diagramma 2})$$

$$c = \frac{F}{F_r} = 1.23 \quad (\text{as per diagram 2})$$

$$c = \frac{F}{F_r} = 1.23 \quad (\text{siehe Diagramm 2})$$

$$1.23 < 1.5 = C_{\text{max}}$$

$$1.23 < 1.5 = C_{\text{max}}$$

$$1.23 < 1.5 = C_{\text{max}}$$

Durata cuscinetti  $n_2 \cdot h = 0.5 \cdot 10^5$

$$\frac{0.5 \cdot 10^5}{n_2} = 2500 \text{ ore}$$

Bearing life  $n_2 \cdot h = 0.5 \cdot 10^5$

$$\frac{0.5 \cdot 10^5}{n_2} = 2500 \text{ hours}$$

Lagerlebensdauer  $n_2 \cdot h = 0.5 \cdot 10^5$

$$\frac{0.5 \cdot 10^5}{n_2} = 2500 \text{ Stunden}$$

In presenza di carico assiale, si consiglia di contattare il Servizio Tecnico Commerciale Brevini.

Per gli alberi in ingresso vedere le rispettive tabelle. I riduttori con uscita albero femmina (FE - FS) sono impiegati normalmente per la trasmissione di sola coppia e non sono adatti a sopportare nessun carico radiale.

Per eventuali informazioni consultare il Servizio Tecnico Commerciale Brevini.

In the event of axial load, it is advisable to contact the Brevini technical commercial service.

For input shafts, see the respective tables.

Gear units with female shaft output are used for the transmission of torque only, and are unsuitable for supporting any radial load.

For information contact the Brevini technical commercial service.

Sollten Axiallastenanliegen, wenden Sie sich bitte an den technischen Kundendienst Brevini.

Für Antriebswellen siehe die betreffenden Tabellen.

Die Getriebe mit Hohlwellenabtrieb (FE - FS) werden normalerweise nur für die Übertragung des Drehmoments eingesetzt und sind absolut ungeeignet für Radiallasten.

Wenden Sie sich bei Rückfragen an den technischen Kundendienst Brevini.

### Carichi sugli alberi di uscita versione FS

Nel montaggio di tipo pendolare si possono generare forze dovute a tre diverse cause:

- A - forza di reazione dovuta all'ancoraggio
- B - forza peso prodotta da riduttore e motore (di solito ininfluente)
- C - eventuale presenza di un tiro cinghia.

Ognuno dei succitati carichi dà origine ad un momento flettente; la risultante vettoriale di tali momenti influisce su:

- durata cuscinetti
- resistenza dell'albero
- efficacia del serraggio mediante giunto.

Nel caso in cui la condizione di carico B assuma una certa rilevanza (p.es. riduttori a due stadi azionati da grossi motori elettrici) e/o si presenti la condizione C, come qualora siano presenti carichi assiali, si raccomanda di consultare il servizio tecnico BREVINI.

Per quanto riguarda i carichi dovuti alla sola reazione, condizione A, nelle tabelle dimensionali sono state riportate le lunghezze minime  $L_{1\text{min}}$  dei bracci di reazione tali da consentire sia la durata ISO  $L_{10}$  dei cuscinetti  $n_2 \cdot h > 10^6$ , che la resistenza dell'albero e l'efficacia del serraggio.

### Loads on output shafts FS version

The torque arm mounting is normally accompanied by three types of forces:

- A - reaction force given by the anchoring
- B - weight of gearbox and motor (usually negligible)
- C - belt-tension force, in case of belt and pulley drive at gear unit input.

Each one of such loading conditions generates a bending moment.

The vector resultant of these moments affects:

- bearing life
- shaft fatigue resistance
- efficiency of the shafts shrink fit.

In case load condition B becomes relevant (for instance 2 stages gearbox driven by large electric motors) and/or in presence of load condition C as well when there are axial loads it is recommended to consult BREVINI technical staff.

Concerning the load due to the reaction force, condition A, the minimum torque arm lengths,  $L_{1\text{min}}$ , have been tabulated in correspondence to the dimensional sheets. Such lengths grant an ISO  $L_{10}$  bearings life  $n_2 \cdot h > 10^6$  as well as shaft resistance under fatigue and efficiency of the shrink fit.

### Belastungen auf den Abtriebswellen Version FS

Bei Aufsteckgetrieben können Kräfte erzeugt werden, die auf drei unterschiedlichen Ursachen beruhen:

- A - Reaktionskraft infolge der Verankerung
- B - Gewicht von Getriebe und Motor (kann in der Regel vernachlässigt werden)
- C - Riemenzugkraft, falls auf der Eingangsseite ein Riemenantrieb vorhanden ist.

Jede dieser drei Belastungen erzeugt ein Biegemoment. Das Vektorialprodukt wirkt sich aus auf:

- Lebensdauer der Lager
- Festigkeit der Welle
- Wirksamkeit der Schrumpfpassung der Welle.

Falls der Lastfall B eine gewisse Bedeutung erhält (Bsp.: zweistufige Getriebe, die durch große Elektromotoren betätigt werden) und/oder der Lastfall C eintritt, sollte man sich beim Vorliegen von axialen Beanspruchungen an das BREVINI-Konstruktionsbüro wenden.

Was Beanspruchungen betrifft, die lediglich auf Lastfall A, also der Reaktionskraft beruhen, stehen in den Dimensionstabellen die Mindestlängen  $L_{1\text{min}}$  der Drehmomentstützen, die sowohl die Lebensdauer ISO  $L_{10}$  der Lager  $n_2 \cdot h > 10^6$  als auch die Festigkeit der Welle und die Wirksamkeit der Schrumpfpassung geben.

Données :  
 Réducteur ED2065 MR  
 Charge radiale appliquée  $F = 80 \text{ kN}$   
 Position de la charge  $X = -55 \text{ mm}$   
 Vitesse de rotation en sortie  $n_2 = 20 \text{ min}^{-1}$

Pour calculer :

Charge radiale admissible  
 $Fr = 65 \text{ kN}$  (voir diagramme 1)

$$c = \frac{F}{Fr} = 1.23 \quad (\text{voir diagramme 2})$$

$$1,23 < 1,5 = C \text{ max}$$

Durée des roulements  $n_2 \cdot h = 0.5 \cdot 10^5$

$$\frac{0.5 \cdot 10^5}{n_2} = 2500 \text{ heures}$$

En présence d'une charge axiale, il est conseillé de prendre contact avec le service technico-commercial Brevini.

Pour les arbres en entrée, consulter les tableaux correspondants.

Les réducteurs avec sortie à arbre femelle (FE - FS) sont normalement utilisés pour la transmission du couple uniquement et ne sont pas adaptés à supporter des charges radiales.

Pour de plus amples informations, prendre contact avec le service technico-commercial Brevini.

### Charges sur les arbres de sortie version FS

Dans l'application de type pendulaire trois conditions différentes de charge peuvent se vérifier:

- A - force de réaction due à l'ancrage
- B - force-poids produite par le réducteur et le moteur (en général sans influence)
- C - présence éventuelle d'une traction de la courroie.

Chacune de ces conditions de charge produit un moment de flexion.

La résultante vectorielle de ces moments a une influence sur:

- la durée de vie des roulements
- la résistance de l'arbre
- l'efficacité du serrage de l'accouplement

Si la charge B est d'une certaine importance (par ex. réducteurs à deux étages actionnés par de gros moteurs électriques) ou en présence de la condition C, mais encore en présence de charges axiales, il est recommandé de consulter le service technique BREVINI.

En ce qui concerne les charges dues seulement à la réaction (condition A), dans les tableaux des dimensions sont reportées les longueurs minimales  $L_{1min}$  des bras de réaction aptes à garantir tant la durée ISO  $L_{10}$  des roulements  $n_2 \cdot h > 10^6$  que la résistance de l'arbre et l'efficacité du serrage.

Datos:  
 Reductor ED2065 MR  
 Carga radial aplicada  $F = 80 \text{ kN}$   
 Posición de la carga  $X = -55 \text{ mm}$   
 Velocidad de salida  $n_2 = 20 \text{ min}^{-1}$

Sirven para calcular:

Carga radial admisible  
 $Fr = 65 \text{ kN}$  (véase el diagrama 1)

$$c = \frac{F}{Fr} = 1.23 \quad (\text{véase el diagrama 2})$$

$$1.23 < 1.5 = C \text{ máx}$$

Duración de los rodamientos  $n_2 \cdot h = 0.5 \cdot 10^5$

$$\frac{0.5 \cdot 10^5}{n_2} = 2500 \text{ horas}$$

Si la carga es axial, se ruega contactar con el Servicio Técnico de Brevini.

Los ejes de entrada se encuentran en las tablas correspondientes.

Los reductores con salida hembra (FE - FS) se emplean generalmente para transmitir sólo el par y no admiten cargas radiales.

Se aconseja contactar con el Servicio Técnico de Brevini.

### Carga sobre los ejes en salida Versión FS

En el montaje del tipo pendular se pueden generar fuerzas debidas a varias causas:

- A - la fuerza de reacción debida al anclaje
- B - la fuerza del peso producida por el reductor y el motor (que normalmente no influye)
- C - la posible presencia de un tirón de correa.

Cada una de las cargas mencionadas da lugar a un momento de flexión; el resultado vectorial de tales momentos influye sobre:

- duración de los cojinetes
- resistencia del eje
- eficacia de la fijación mediante la unión.

En el caso en que las condiciones de carga B asumieran cierta importancia (por ej. reductores de dos etapas accionados por grandes motores eléctricos) o que se presentara la condición C, al igual que con las cargas coaxiales, se recomienda ponerse en contacto con el Servicio Técnico BREVINI.

Por lo que respecta a las cargas debidas por la mera reacción, condición A, en las tablas de dimensiones se encuentran indicadas las larguras mínimas de los brazos de reacción,  $L_{1min}$ , de manera que se consienta tanto la duración ISO  $L_{10}$  de los cojinetes  $n_2 \cdot h > 10^6$ , como la resistencia del eje y la eficacia de la fijación.

Dados:  
 Redutor ED2065 MR  
 Carga radial aplicada  $F = 80 \text{ kN}$   
 Posição da carga  $X = -55 \text{ mm}$   
 Rotação na saída  $n_2 = 20 \text{ min}^{-1}$

Com os quais calculamos:

Carga radial admissível  
 $Fr = 65 \text{ kN}$  (ver o diagrama 1)

$$c = \frac{F}{Fr} = 1.23 \quad (\text{ver o diagrama 2})$$

$$1,23 < 1,5 = C \text{ máx}$$

Duração dos coxins  $n_2 \cdot h = 0.5 \cdot 10^5$

$$\frac{0.5 \cdot 10^5}{n_2} = 2500 \text{ horas}$$

Em presença de carga axial, é aconselhável entrar em contato com o Serviço Técnico Comercial da Brevini.

Para os eixos de entrada, ver as respectivas tabelas. Os reductores com saída de eixo fêmea (FE - FS) são empregados normalmente para a transmissão exclusiva de torque e não são adequados a suportar nenhuma carga radial.

Para obter informações eventuais, consultar o Serviço Técnico Commercial da Brevini.

### Cargas nos eixos de saída versão FS

Na montagem de tipo pendular podem-se gerar forças devido a três causas diferentes:

- A - força de reação devido à ancoragem
- B - força do peso produzida por reductor e motor (geralmente não influente)
- C - eventual presença de uma tensão da correa

Cada uma das acima citadas cargas origina um momento de flexão; a resultante vectorial destes momentos influencia na:

- duração dos rolamentos
- resistência do eixo
- eficácia do aperto mediante disco.

No caso em que a condição de carga B assumir uma certa relevância (por ex.: reductores com dois estágios accionados por grandes motores elétricos) e/ou se apresentar a condição C, como também no caso em que se apresentarem cargas axiais, recomenda-se consultar o serviço técnico BREVINI.

Em relação às cargas devido só à reação, condição A, nas tabelas dimensionais foram indicados os comprimentos mínimos  $L_{1min}$  dos braços de reação que correspondem tanto à duração ISO  $L_{10}$  dos rolamentos  $n_2 \cdot h > 10^6$ , quanto à resistência da árvore e à eficácia do aperto.

Tali valori sono riferiti ai dati di coppia limite e alla posizione di ancoraggio del braccio di reazione definita dalla quota  $L_5$  (riportata nelle tavole dimensionali). Nel calcolo delle lunghezze minime dei bracci di reazione non si è tenuto conto della presenza di eventuali carichi assiali.

Qualora si verificasse che:

The tabulated  $L_{1min}$  are referred to the limit torques as well as to the anchoring position of the torque arm. Such position is defined by measure  $L_5$  (stated on the dimensional sheets). When calculating  $L_{1min}$  no axial load has been considered.

In case of an axial load:

$$F_a > \frac{0.1 T_{2lim}}{L_{1min}}$$

consultare il servizio tecnico BREVINI.

consult BREVINI technical staff.

### AVVERTENZA

Onde non generare carichi anomali sugli alberi, tali da compromettere la resistenza a fatica, si raccomanda di realizzare un ancoraggio del giunto braccio di reazione libero secondo l'asse dell'albero.

Si raccomanda inoltre che il vincolo tangenziale venga ammortizzato mediante elementi in gomma e/o ammortizzatori.

Tenere conto che il senso secondo cui agisce la forza di reazione, A, dipende dal senso di rotazione dell'albero di uscita.

Verificare sempre che il giunto di serraggio sia in grado di trasmettere la coppia massima prevista per la specifica applicazione.

### WARNING

We strongly recommend that the anchoring point of the torque arm is allowed to float axially to avoid the possibility of any additional side load on the output shaft, which may create excessive stresses.

The torque arm should incorporate a flexible element in the tangential direction to reduce shock loads.

Take into account that the way of the reaction force, A, depends on the direction of rotation of the output shaft.

Remember always to check the shrink disc coupling can transmit the max. torque for each specific application.

## Verifica dell'accoppiamento mediante giunto di serraggio

### 1. Impiego del secondo centraggio Za.

- a) Si deve utilizzare il secondo centraggio (avente diametro Za) quando non è verificata la seguente relazione:

$$X3 > 0,5 D_3$$

Za = diametro dell'albero condotto (vedi tab. a pag. 26)

X3 = parte di albero interessata al serraggio

- b) Nel caso venga utilizzato il secondo centraggio è opportuno che l'albero maschio porti una boccia di bronzo o simile per evitare corrosioni che rendono difficoltoso lo smontaggio. (N.B.: questa zona non deve essere lubrificata)

### 2. Lunghezza utile di accoppiamento

X3. La parte di albero femmina interessata all'accoppiamento deve soddisfare la seguente relazione:

$$X3 < 1.1 \cdot l$$

l = lunghezza del cono del giunto.

Nel caso questo non venga rispettato, si avranno difficoltà di smontaggio.

(N.B.: questa zona NON deve essere lubrificata).

## Clamping capacity of the shrink disc

### 1. When to use the second pilot Za.

- a) Additional pilot (dia. Za) should be used in cases where the following conditions is not met:

$$X3 > 0,5 D_3$$

Za = driven shaft dia. (see table on pag. 26)

X3 = driven shaft clamping length

- b) When the second pilot is used, it is better to fit a bronze bush on the corresponding mating part of the male shaft. This to prevent corrosion which would make demounting difficult. (This area should not be lubricated)

### 2. Clamping length X3. The clamping length of gearbox hollow shaft shall must comply with the following condition:

$$X3 < 1.1 \cdot l$$

l = length of shrink disc cone.

This is to avoid demounting problems.

(This area should not be lubricated)

Diese Werte beziehen sich auf die Tabellendaten des Grenzdrehmoments und die Verankerungsposition der Drehmomentstütze, die durch den Wert  $L_5$  gegeben ist (steht in den Dimensionstabellen).

Bei der Berechnung der Mindestlängen der Drehmomentstützen wurde das Vorliegen eventueller Axialbeanspruchungen nicht berücksichtigt.

Falls:

wenden Sie sich bitte an das BREVINI-Konstruktionsbüro.

### ACHTUNG

Um eine zusätzliche Belastung auf den Abtriebswellen zu vermeiden, die zur Überschreitung der Ermüdungsgrenze führen könnte, sollte die Verankerungsstelle der Drehmomentstütze unbedingt so beschaffen sein, daß diese sich in der Längsrichtung der Welle frei bewegen kann.

Die Drehmomentstütze sollte in der Tangentialrichtung mit Gummielementen und/oder Stoßdämpfern versehen werden, um die Stoßbelastungen zu verringern.

Auch berücksichtigen, daß die Richtung, in der die Reaktionskraft A wirkt, von der Drehrichtung der Abtriebswelle abhängt. Immer sicherstellen, daß die Schrumpfscheibe in der Lage ist, das für die spezifische Anwendung vorgesehene Höchstdrehmoment zu übertragen.

## Prüfung der Schrumpfscheiben-Ausführung

### 1. Verwendung der zweiten Zentrierung Za.

- a) Die zweite Zentrierung (mit Durchmesser Za) muß dann verwendet werden, wenn die folgende Bedingung nicht vorliegt:

$$X3 > 0,5 D_3$$

wobei Za = Durchmesser der Abtriebswelle (vgl. Tabelle auf Seite 26) und

X3 = Länge der Welle in der Schrumpfpasung ist.

- b) Wenn die zweite Zentrierung verwendet wird, sollte die Vollwelle mit Bronzebuchse oder ähnlichem versehen sein, damit Korrosionserscheinungen vermieden werden, die beim Auseinandernehmen Schwierigkeiten bereiten könnten (Anm.: Dieser Bereich darf nicht geschmiert werden).

### 2. Nützliche Schrumpflänge X3. Der Teil der hohlen Zylinderwelle, der in der Schrumpfscheibe sitzt, muß der folgenden Beziehung gerecht werden:

$$X3 < 1.1 \cdot l$$

wobei l = Länge des Schrumpfscheibenkonus. Wenn diese Bedingung nicht eingehalten wird, ergeben sich Schwierigkeiten beim Auseinandernehmen.

(Anm.: Dieser Bereich darf NICHT geschmiert werden.)

Ces valeurs se réfèrent aux données de couple limite et à la position d'ancrage du bras de réaction définie par la cote  $L_5$  (indiquée dans les tableaux des dimensions).

Dans le calcul des longueurs minimales des bras de réaction il n'a pas été tenu compte de la présence éventuelle de charges axiales.

Au cas où se vérifierait la condition:

$$F_a > \frac{0.1 T_{2lim}}{L_{1min}}$$

contacter le service technique BREVINI.

### IMPORTANT

Afin de ne pas générer des charges anormales sur les arbres qui pourraient compromettre la résistance à la fatigue, il est recommandé de réaliser un accouplement libre suivant l'axe de l'arbre. Il est également recommandé d'amortir la force tangentielle par Silentbloks en caoutchouc ou des amortisseurs.

Ne pas oublier que le sens de la force de réaction, A, dépend du sens de rotation de l'arbre de sortie.

Vérifier toujours que l'accouplement est en mesure de transmettre le couple maximum prévue pour l'application.

### Vérification de l'accouplement par disque de serrage

#### 1. Utilisation du deuxième centrage $Z_a$ .

- a) Le deuxième centrage (ayant un diamètre  $Z_a$ ) doit être utilisé quand la formule suivante ne se vérifie pas:

$$X3 > 0,5 D_3$$

$Z_a$  = diamètre de l'arbre mené (voir tab. page 27)

$X3$  = partie de l'arbre intéressée par le serrage

- b) Si on utilise le deuxième centrage, il faut que l'arbre mâle porte une bague en bronze ou similaire pour éviter les corrosions rendant le démontage difficile.

(N.B.: cette zone ne doit pas être lubrifiée)

#### 2. Longueur utile d'accouplement $X3$ .

La partie d'arbre femelle intéressée par l'accouplement doit satisfaire la formule suivante:

$$X3 < 1.1 \cdot l$$

$l$  = longueur du cône de l'accouplement

Si cela ne se vérifie pas, le démontage sera difficile.

(N.B.: cette zone ne doit pas être lubrifiée)

Dichos valores se refieren a los datos del par límite y a la posición de anclaje del brazo de reacción definida como cota  $L_5$  (indicada en las tablas de dimensiones). Para el cálculo de las larguras mínimas de los brazos de reacción, no se ha tenido en cuenta la presencia de cargas coaxiales.

En el caso en que se verificase:

ponerse en contacto con el Servicio Técnico BREVINI

### ADVERTENCIA

Para no generar cargas anómalas sobre los ejes que pudieran comprometer tanto la resistencia de fatiga, se recomienda realizar un anclaje de la unión del brazo de reacción libre según el eje del árbol. También se recomienda que el vínculo tangencial se amortice mediante elementos de goma y/o amortiguadores.

Tener presente el sentido en el cual actúa la fuerza de reacción A, que depende del sentido de giro del eje en salida.

Recordarse además de comprobar que la unión de fijación sea capaz de transmitir el par máximo previsto para la aplicación en específico.

### Verificación del acoplamiento mediante anillo de contracción

#### 1. Utilización del segundo centrado $Z_a$ .

- a) El centrado adicional (con diámetro  $Z_a$ ), se utiliza cuando no se verifique la siguiente relación:

$$X3 > 0,5 D_3$$

$Z_a$  = diámetro del árbol guiado. (Ver tabla de la pág. 27)

$X3$  = parte del árbol comprendida en la fijación

- b) En el caso en que se utilice el centrado adicional, es oportuno que el árbol macho lleve un casquillo de bronce o similares, para evitar posibles corrosiones que complicarían el desmontaje.

(N.B.: esta zona no tiene que estar lubricada).

#### 2. Largura útil de acoplamiento $X3$ .

La parte hembra del eje comprendida en el acoplamiento, tiene que satisfacer las siguiente relación:

$$X3 < 1.1 \cdot l$$

$l$  = largura del cono de la unión.

Si esto no se respeta, se encontrarán dificultades a la hora de desmontar.

(N.B.: esta zona NO tiene que estar lubricada)

Estes valores referem-se aos dados de torque limite reação definida da cota  $L_5$  (indicada nas tabelas dimensionais).

No cálculo dos comprimentos mínimos dos braços de reação não foi considerada a presença de eventuais cargas axiais.

Ao se verificar que:

Consultar o serviço técnico BREVINI.

### AVISO

Para não gerar cargas anormais nos eixos, que comprometam a resistência por fadiga, recomenda-se realizar a ancoragem do braço de reação livre no sentido axial do eixo. Recomenda-se também que o vínculo tangencial seja amortecido com elementos de borracha e/ou amortecedores. Lembre-se que o sentido no qual atua a força de reação A, depende do sentido de giro do eixo de saída.

Verificar sempre que o disco de contração seja capaz de transmitir o torque máximo previsto para a específica aplicação.

### Verificação do acoplamento mediante disco de contração

#### 1. Emprego da segunda centragem $Z_a$ .

- a) Deve-se utilizar a segunda centragem (com diámetro  $Z_a$ ) quando não se verificar a seguinte relação:

$$X3 > 0,5 D_3$$

$Z_a$  = diámetro do eixo conduzida (vide tab. na pág. 27)

$X3$  = parte interessada do eixo destinado

- b) Ser for utilizada a segunda centragem é oportuno montar no eixo macho uma bucha de bronze ou similar para evitar corrosões que dificultem a desmontagem.

(N.B.: esta zona não deve ser lubrificada)

#### 2. Comprimento útil de acoplamento $X3$ .

A parte de eixo fêmea interessada ao acoplamento deve satisfazer a seguinte relação:

$$X3 < 1.1 \cdot l$$

$l$  = comprimento do cone do disco.

Se este não for respeitado, ocorrerá dificuldades na desmontagem.

(N.B.: esta zona NÃO deve ser lubrificada).



**3. Coppia trasmissibile  $T_2$ .** I valori di coppia trasmissibile mediante il giunto di serraggio vengono definiti dal costruttore del giunto di serraggio stesso. Normalmente le tolleranze raccomandate nell'accoppiamento tra i due alberi per una corretta trasmissione della coppia sono H7-h6

**4. Carico assiale  $F_a$ .** La forza di attrito che permette la trasmissione della coppia è evidentemente la stessa che si oppone allo sfilamento assiale del riduttore, pertanto:

**3. Transmissible torque  $T_2$ .** The values of transmissible torques are stated by the shrink disc manufacturer. Normally the tolerances of the mating shafts granting proper torque transmission are: H7-h6

**4. Axial load  $F_a$ .** The friction resistance, which makes torque transmission possible, prevents the mating shafts from sliding axially, consequently:

**3. Übertragbares Drehmoment  $T_2$ .** Die Werte des übertragbaren Drehmoments werden vom Hersteller der Schrumpfscheibe angegeben. Für eine korrekte Übertragung des Drehmoments wird für die Passung der beiden Wellen in der Regel eine Toleranz H7-h6 empfohlen.

**4. Axiale Belastung  $F_a$ .** Die Reibungskraft, die die Übertragung des Drehmoments gestattet, ist offensichtlich die gleiche, die sich dem axialen Herausziehen des Getriebes widersetzt, d.h.:

$$F_a \text{ max} = \frac{T_2 \cdot 2}{Z_a} \text{ (kN)}$$

Nel caso in cui si manifesti un carico assiale la coppia trasmissibile si riduce.

In the presence of an axial load the transmissible torque will be reduced with a vector effect.

Falls eine axiale Belastung vorliegt, reduziert sich das übertragbare Drehmoment.

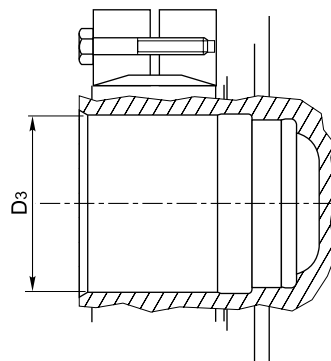
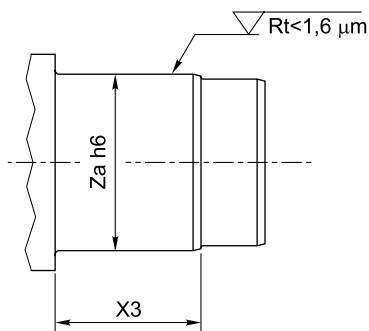

## 5. POTENZA TERMICA $P_T$ [kW]

Le potenze termiche dei riduttori sono indicate nelle tabelle che riassumono le prestazioni tecniche dei vari stadi di riduzione. I valori pubblicati fanno riferimento ad un impiego continuo del riduttore:

- Con lubrificazione a sbattimento
- Montato orizzontalmente
- Ad una velocità di ingresso riduttore di 1500 min<sup>-1</sup>
- Per una temperatura massima dell'olio di 80 °C (olio VG150)
- Ad una temperatura ambiente di 20 °C
- Nella condizione di impiego "ambiente grande".

## 5. THERMAL RATING $P_T$ [kW]

The thermal ratings of the gear units are given in the tables summarizing the technical performance of the various reduction stages.

The values given refer to a continuous use of the gear unit:

- With splash lubrication
- Horizontally mounted
- At a gear unit input speed of 1500 min<sup>-1</sup>
- For a max. oil temperature of 80 °C (oil VG150)
- At an ambient temperature of 20 °C
- In the "large ambient" condition of use.

## 5. WÄRMELEISTUNG $P_T$ [kW]

Die Wärmeleistungen der Getriebe sind in den Tabellen aufgeführt, die die technischen Leistungen der verschiedenen Übersetzungsstufen zusammenfassen.

Die angegebenen Daten beziehen sich auf einen kontinuierlichen Getriebeeinsatz:

- Spritzschmierung
- Horizontale Einbaulage
- Antriebsdrehzahl des Getriebes 1500 min<sup>-1</sup>
- Für eine Höchsttemperatur des Öls von 80 °C (Öl VG150)
- Raumtemperatur von 20 °C
- Einsatzbedingung "großes Arbeitsumfeld".

**3. Couple transmissible  $T_2$ .** Les valeurs de couple transmissible par le disque de serrage sont définies par le constructeur du disque de serrage. Normalement les tolérances recommandées dans l'accouplement entre les deux arbres pour une transmission correcte du couple sont H7-h6

**4. Charge axiale  $F_a$ .** La force de friction qui permet la transmission du couple est bien entendu la même qui s'oppose au déboîtement axial du réducteur, donc:

**3. Par transmissible  $T_2$ .** Los valores del par que se pueden transmitir mediante anillo de contracción tienen que ser definidos por el fabricante de la misma unión. Normalmente, las tolerancias recomendadas para el acoplamiento entre los dos ejes, manteniendo una transmisión correcta del par, son: H7-h6

**4. Carga axial  $F_a$ .** La fuerza de fricción que permite la transmisión del par es, evidentemente, la misma que se opone al deslizamiento axial del reductor y, por lo tanto:

**3. Torque transmissível  $T_2$ .** Os valores de torque transmissível mediante o disco de contração são definidos pelo próprio fabricante do disco de aperto. Geralmente as tolerâncias recomendadas no acoplamento entre os dois eixos para uma correta transmissão do torque são H7-h6

**4. Carga axial  $F_a$ .** A força de atrito que permite a transmissão do torque é evidentemente a mesma que se opõe ao deslizamento axial do reductor, portanto:

$$F_a \text{ max} = \frac{T_2 - 2}{Z_a} \text{ (kN)}$$

En présence d'une charge axiale, le couple transmissible diminue.

Si no se manifestara una carga axial el par transmissible se reduciría.

Em presença de uma carga axial o torque transmissível se reduz.

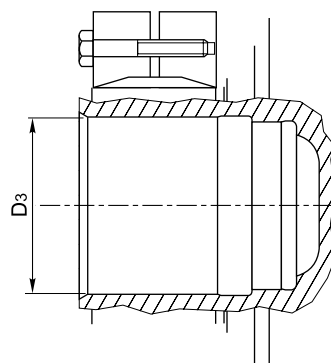
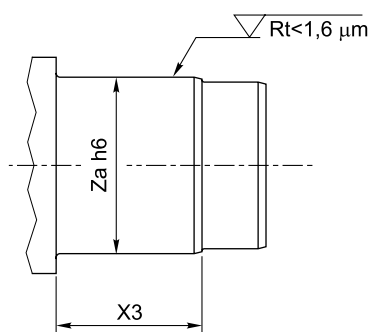

## 5. PUISSANCE THERMIQUE $P_T$ [kW]

Les puissances thermiques des réducteurs sont indiquées dans les tableaux qui résument les performances techniques des différents étages de réduction. Les valeurs données se réfèrent à un service continu du réducteur:

- Avec une lubrification par barbotage
- Monté horizontalement
- Avec une vitesse d'entrée du réducteur de 1500 min<sup>-1</sup>
- Pour une température maximale de l'huile de 80 °C (huile VG150)
- Avec une température ambiante de 20 °C
- Dans la condition d'emploi "milieu ambiant grand".

## 5. POTENCIA TÉRMICA $P_T$ [kW]

Las potencias térmicas de los reductores se indican en las tablas que sintetizan las prestaciones técnicas de las diferentes etapas.

Los valores se refieren a reductores para uso continuo con las siguientes características:

- Lubricación por borboteo
- Montaje horizontal
- Velocidad de entrada 1500 min<sup>-1</sup>
- Temperatura máxima del aceite 80 °C (aceite VG150)
- Temperatura ambiente 20 °C
- Funcionamiento en un "ambiente grande"

## 5. POTÊNCIA TÉRMICA $P_T$ [kW]

As potências térmicas dos redutores são indicadas nas tabelas que sintetizam o desempenho técnico dos vários estágios de redução.

Os valores publicados fazem referência a um emprego contínuo do reductor:

- Com lubrificação por agitação
- Montado horizontalmente
- A uma velocidade de entrada no reductor de 1500 min<sup>-1</sup>
- Para uma temperatura máxima do óleo de 80 °C (óleo VG150)
- A uma temperatura ambiente de 20 °C
- Na condição de emprego "ambiente grande".

**Fattore K**

Nel caso di cicli di lavoro che prevedono un impiego intermittente del riduttore e/ o alla presenza di una temperatura ambiente diversa da 20 °C, la potenza termica del riduttore può essere adeguata all'applicazione specifica tramite il fattore K

**K Factor**

With work cycles requiring an intermittent use of the gear unit and/or the presence of an ambient temperature different from 20 °C, the gear unit thermal rating can be adjusted to the specific application by means of the K factor.

**K - Faktor**

Bei Arbeitszyklen des Getriebes mit Aussetzbetrieb und/oder bei Raumtemperaturen, die von 20 °C abweichen, kann die Wärmeleistung des Getriebes mithilfe des K - Faktors an die spezifische Anwendung angepasst werden

**K**

Ore di lavoro giornaliere Hours of work per day Arbeitsstunden pro Tag	Temperatura ambiente / Ambient temperature / Umgebungstemperatur [°C]				
	10°	20°	30°	40°	50°
10	1.15	1	0.85	0.7	0.6
8	1.25	1.1	1	0.85	0.7
6	1.4	1.25	1.1	1	0.85
4	1.6	1.4	1.25	1.1	1
2	1.8	1.6	1.4	1.25	1.1

**Fattore S**

Nel caso in cui la velocità in ingresso sia diversa da 1500 rpm, l'adeguamento della potenza termica alla situazione specifica può avvenire tramite l'impiego del fattore S

**S Factor**

If the input speed is different from 1500 rpm, the thermal rating can be adjusted to the specific situation by means of the S factor

**S - Faktor**

Bei einer von 1500 U/min abweichenden Antriebsdrehzahl kann die Wärmeleistung der spezifischen Situation mithilfe des Faktors S angepasst werden

**S**

S	n <sub>1</sub> [rpm]			
	1750	1500	1000	500
S	0.94	1	1.05	1.1

**Fattore R**

Nel caso in cui il riduttore sia collocato in un ambiente ristretto oppure all'aperto, la potenza termica può essere modificata con l'ausilio del fattore R

**R Factor**

If the gear unit is located in a confined space or outdoors, the thermal rating can be modified with the aid of the R factor

**R - Faktor**

Falls das Getriebe in einer engen Umgebung oder im Freien aufgestellt ist, kann die Wärmeleistung mithilfe des Faktors R geändert werden

**R**

R	Ambiente piccolo Small space Kleiner Raum	Ambiente grande Large space Großer Raum	All'aperto Outdoors Im Freien
R	0.70	1.00	1.35

Nel caso più generale la adeguata potenza termica del riduttore risulterà:

In the most general case the adequate thermal rating of the gear unit will be:

Ganz allgemein folgt die geeignete Wärmeleistung aus der folgenden Formel:

$$P_{T1} = P_T \cdot K \cdot S \cdot R$$

La potenza termica deve essere superiore alla potenza P da trasmettere in tutte le condizioni del ciclo di impiego.

The thermal rating must be higher than the power P to be transmitted in all operating cycle conditions.

Unter allen Bedingungen des Arbeitszyklus muss die Wärmeleistung höher sein als die zu übertragende Leistung P.

Nel caso in cui la potenza termica del riduttore risulti inferiore alla potenza da trasmettere, anche solo in una condizione dell'eventuale ciclo di impiego, occorre prevedere la presenza di un circuito ausiliario di raffreddamento.

If the thermal rating of the gear unit is less than the power to be transmitted, even in just one condition of the possible operating cycle, an auxiliary cooling circuit must be provided.

Falls die Wärmeleistung des Getriebes niedriger als die zu übertragende Leistung ist, selbst in einer einzigen Bedingung des Zyklus, muss ein zusätzliches Kühlsystem installiert werden.

Per la selezione di tale circuiti, rimandiamo al Capitolo: Lubrificazione.

For selecting the circuits, see the Chapter: Lubrication.

Für die Auswahl des Kühlsystems siehe Kapitel: Schmierung.

$$P < P_{T1}$$

### Facteur K

Dans le cas de cycles de fonctionnement qui prévoient un service intermittent du réducteur et/ou une température ambiante différente de 20 °C, la puissance thermique du réducteur pourra être adaptée à l'application spécifique avec le facteur K

### Factor K

Si el ciclo de lavoro contempla un uso intermitente del reductor o una temperatura ambiente distinta de 20 °C, la potencia térmica del reductor se puede corregir por medio del factor K

### Fator K

No caso de ciclos de trabalho que prevejam um emprego intermitente do redutor e/ou na presença de uma temperatura ambiente diferente de 20 °C, a potência térmica do redutor poderá ser adequada à aplicação específica através do fator K

## K

Heures de fonctionnement par jour Horas de trabajo diarias Horas de trabalho diárias	Température ambiante / Temperatura ambiente / Temperatura ambiente [°C]				
	10°	20°	30°	40°	50°
10	1.15	1	0.85	0.7	0.6
8	1.25	1.1	1	0.85	0.7
6	1.4	1.25	1.1	1	0.85
4	1.6	1.4	1.25	1.1	1
2	1.8	1.6	1.4	1.25	1.1

### Facteur S

Dans les cas où la vitesse d'entrée est différente de 1 500 tr/min, l'adaptation de la puissance thermique au cas spécifique pourra se faire en utilisant le facteur S

### Factor S

Si la velocidad de entrada es distinta de 1500 rpm la potencia térmica corregir por medio del factor S

### Fator S

Caso a velocidade de entrada seja diferente de 1500 rpm, a adequação da potência térmica à situação específica poderá ocorrer através do emprego do fator S

## S

S	n <sub>1</sub> [rpm]			
	1750	1500	1000	500
S	0.94	1	1.05	1.1

### Facteur R

Dans le cas où le réducteur serait placé en un milieu ambiant restreint ou à l'extérieur, la puissance thermique pourra être modifiée en appliquant le facteur R

### Factor R

Si el reductor está colocado en un ambiente pequeño o a la intemperie la potencia térmica se puede corregir por medio del factor R

### Fator R

Caso o redutor seja colocado em um ambiente fechado ou ao ar livre, a potência térmica poderá ser modificada com o auxílio do fator R

## R

R	Milieu ambiant petit Ambiente pequeño Ambiente pequeno	Milieu ambiant grand Ambiente grande Ambiente grande	En plein air Al aire libre Área aberta
R	0.70	1.00	1.35

En général, la puissance thermique du réducteur sera:

En el caso más general la potencia térmica del reductor será:

No caso mais geral, a potência térmica adequada do redutor será:

$$P_{T1} = P_T \cdot K \cdot S \cdot R$$

La puissance thermique doit être supérieure à la puissance à transmettre P dans toutes les conditions du cycle de fonctionnement.

Si la puissance thermique du réducteur est inférieure à la puissance à transmettre, même en une seule condition du cycle de fonctionnement, il faudra prévoir la mise en place d'un circuit auxiliaire de refroidissement.

Pour la sélection de ce circuit, se référer au chapitre : Graissage.

La potencia térmica debe ser mayor que la que se debe transmitir P en cualquier condición del ciclo de utilización.

Cuando es menor aunque sea en una sola condición del ciclo, es preciso instalar un circuito de enfriamiento auxiliar.

Antes de hacerlo conviene consultar el capítulo: Lubricación.

A potência térmica deve ser superior à potência a ser transmitida P em todas as condições do ciclo de trabalho.

Caso a potência térmica do redutor seja inferior à potência a ser transmitida, mesmo que somente em uma condição do eventual ciclo de trabalho, será necessário prever a presença de um circuito auxiliar de arrefecimento.

Para efetuar a seleção desses circuitos, consultar o Capítulo: Lubrificação.

$$P < P_{T1}$$

## 6. ESEMPIO SELEZIONE RIDUTTORE

### Dati per la selezione

**Motore primo:**  
Elettrico 1.5 kW a 1500 min<sup>-1</sup>

**Macchina azionata:**  
nastro trasportatore non uniformemente alimentato  
Servizio: continuo 10 ore al giorno  
Numero di avviamenti all'ora: 1  
Coppia richiesta di funzionamento: 4900 Nm  
Coppia massima all'avviamento: 9800 Nm  
Velocità di rotazione: 1.85 min<sup>-1</sup>  
Vita richiesta per la trasmissione: 10000 h  
Posizione di funzionamento: orizzontale  
Temperatura ambiente: 30 °C  
Ambiente di lavoro: grande.

### Selezione del riduttore

Rapporto richiesto: 1500 / 1.85 = 810  
Fattore di applicazione K<sub>A</sub>: 1.25  
Coppia per la selezione del riduttore:

$$T_{2R} = 5000 \times K_A \times CS = 6125 \text{ Nm}$$

Il riduttore da selezionare deve avere una T<sub>2</sub> > T<sub>2R</sub> coppia di riferimento per la selezione del riduttore.

Quindi andare a pag. 33 e dalla tabella selezionare nella colonna T<sub>N</sub> il valore immediatamente più grande del valore ottenuto (T<sub>2R</sub>=6125) e cioè 6400 Nm; sulla stessa riga nella colonna "Tipo" si leggerà che il riduttore idoneo sarà una grandezza 065; dalla corrispondente pag. 104 nella tabella "Dati tecnici" selezionare il rapporto "ieff" più vicino a quello richiesto di i=810, che sarà ieff=771.8, quindi alla colonna corrispondente a 1500 min<sup>-1</sup> in corrispondenza del rapporto selezionato si leggerà un T<sub>2</sub>=7348 Nm e di conseguenza il riduttore sarà in configurazione di "EQ4065".

La coppia massima del riduttore EQ4065  
T<sub>2max</sub> = 10000 Nm > 9500 Nm  
La capacità termica del riduttore EQ4065  
P<sub>T</sub> = 8 kW.

Causa la temperatura ambiente occorre considerare il coefficiente K per cui la capacità termica del riduttore diventa:  
P<sub>T1</sub> = 8 x 0.85 = 6.8 kW  
Essendo la velocità in ingresso pari a 1500 min<sup>-1</sup> il fattore S = 1

Potenza richiesta dalla applicazione:  
P = 4900 x 1.9 / 9550 = 0.97 kW  
Essendo 6.8 kW > 0.97 kW non risulta essere necessario alcun sistema di raffreddamento ausiliario del riduttore.

### N.B. Importante

Applicazioni che:

- richiedono valori di durata diverse dalle 10000 ore
- presentano velocità in entrata diverse da quelle indicate a catalogo
- sono caratterizzate da cicli di lavoro con carichi e velocità variabili
- prevedono la presenza di carichi assiali sull'albero in ingresso / uscita del riduttore devono essere analizzate specificatamente, tramite l'ausilio di programmi di calcolo dedicati, disponibili presso l'organizzazione di vendita di Brevini Riduttori.

## 6. EXAMPLE SELECTION GEAR UNIT

### Selection data

**Prime mover:**  
Electric 1.5 kW a 1500 min<sup>-1</sup>

**Machine driven:**  
conveyor belt not uniformly fed  
Duty: continuous 10 hours a day  
Number of starts per hour: 1  
Required operating torque: 4900 Nm  
Max. torque on start: 9800 Nm  
Rotation speed: 1.85 min<sup>-1</sup>  
Required transmission life: 10000 h  
Operating position: horizontal  
Ambient temperature: 30 °C  
Working site large space

### Gear unit selection

Ratio required: 1500 / 1.85 = 810  
Application factor K<sub>A</sub>: 1.25  
Torque for gear unit selection:

$$T_{2R} = 5000 \times K_A \times CS = 6125 \text{ Nm}$$

The gear unit to be selected must have a T<sub>2</sub> > T<sub>2R</sub> reference torque for gear unit selection.

Then go to page 33, from the table choose in column T<sub>N</sub> the value immediately higher than the value obtained (T<sub>2R</sub>=6125), that is 6400 Nm; in the same line of the "Type" column you can read that the right gearbox is size 065; from the corresponding page 104 in the table "Technical data" choose the "ieff" value that is nearest to the requested i=810: this ieff will be 771.8. Then from the column corresponding to 1500 min<sup>-1</sup>, in correspondence to the selected ratio, you will read T<sub>2</sub>=7348 Nm: therefore the correct gearbox will have a "EQ4065" configuration.

Max. torque of gear unit EQ4065  
T<sub>2max</sub> = 10000 Nm > 9500 Nm  
Thermal capacity of gear unit EQ4065  
P<sub>T</sub> = 8 kW.  
Due to the ambient temperature the K factor must be considered, therefore the thermal capacity of the gear unit becomes:  
P<sub>T1</sub> = 8 x 0.85 = 6.8 kW  
As the input speed is equal to 1500 min<sup>-1</sup> the S factor = 1

Power required by the application:  
P = 4900 x 1.9 / 9550 = 0.97 kW  
As 6.8 kW > 0.97 kW no gear unit auxiliary cooling system is required.

### NOTE Important

Applications that:

- require duration values different from 10000 h
- have different input speeds from those given in the catalogue
- are characterized by work cycles with variable speeds and loads
- foresee the presence of axial loads on the gear unit input / output shaft must be examined separately, with the aid of dedicated calculation programs, available from the Brevini Riduttori sales organization.

## 6. BEISPIEL EINER GETRIEBEAUSWAHL

### Auswahldaten

**Primärmotor:**  
Elektromotor 1.5 kW bei 1500 min<sup>-1</sup>

**Angetriebene Maschine:**  
Transportband mit ungleichmäßiger Beschickung  
Betrieb: kontinuierlich 10 Stundentäglich  
Anzahl der Starts pro Stunde: 1  
Erforderliches Betriebsdrehmoment: 4900 Nm  
Maximales Anfahrtdrehmoment: 9800 Nm  
Drehzahl: 1.85 min<sup>-1</sup>  
Gewünschte Dauer: 10000 h  
Einbaulage: horizontal  
Umgebungstemperatur 30°C  
Arbeitsumfeld groß

### Getriebeauswahl

Gewünschte Übersetzung: 1500 / 1.85 = 810  
Anwendungsfaktor K<sub>A</sub>: 1.25  
Drehmoment für die Getriebeauswahl:

$$T_{2R} = 5000 \times K_A \times CS = 6125 \text{ Nm}$$

Das auszuwählende Getriebe muss ein Bezugsdrehmoment von T<sub>2</sub> > T<sub>2R</sub> für die Getriebeauswahl aufweisen.

Wählen Sie in der Tabelle auf Seite 33 in Spalte T<sub>N</sub> den unmittelbar höheren Wert nach dem zuvor errechneten Wert (T<sub>2R</sub>=6125), d.h. 6400 Nm; in derselben Zeile können Sie in der Spalte "Typ" ablesen, dass die geeignete Getriebegröße 065 ist; wählen Sie jetzt auf Seite 104 in der Tabelle "Technische Daten" den Wert "ieff", der dem gewünschten von i = 810 am nächsten kommt, d.h. ieff=771.8; in der 1500 min<sup>-1</sup> entsprechenden Spalte können Sie auf Höhe des gewünschten Verhältnisses T<sub>2</sub>=7348 Nm ablesen; die korrekte Getriebekonfiguration ist demnach "EQ4065".

Das maximale Drehmoment des Getriebes EQ4065

T<sub>2max</sub> = 10000 Nm > 9500 Nm  
Wärmeleistung des Getriebes EQ4065  
P<sub>T</sub> = 8 kW  
Aufgrund der Raumtemperatur muss der K - Faktor berücksichtigt werden; die Wärmeleistung des Getriebes wird demnach:  
P<sub>T1</sub> = 8 x 0.85 = 6.8 kW  
Da die Antriebsdrehzahl 1500 min<sup>-1</sup> beträgt, ist der Faktor S = 1

Für die Anwendung erforderliche Leistung:  
P = 4900 x 1.9 / 9550 = 0.97 kW  
Da 6.8 kW > 0.97 kW ist kein zusätzliches Kühlsystem des Getriebes erforderlich.

### Hinweis Wichtig

Anwendungen mit:

- von 10000 Betriebsstunden abweichenden Werten
- Antriebsdrehzahlen, die von den im Katalog aufgeführten Werten abweichen
- regelbaren Arbeitszyklen und Drehzahlen
- Axiallasten auf der Antriebs-/ Abtriebswelle des Getriebes müssen separat mithilfe von spezifischen Rechenprogrammen analysiert werden, die von der Vertriebsorganisation Brevini Riduttori bezogen werden können.

## 6. EXEMPLE DE SÉLECTION DU RÉDUCTEUR

### Renseignements utiles pour la sélection

**Moteur primaire :**  
Électrique 1,5 kW à 1500 min<sup>-1</sup>

**Machine menée :**  
bande transporteuse non uniformément alimentée  
Service : continu 10 heures par jour  
Nombre de démarrages par heure : 1  
Couple de fonctionnement requis : 4900 Nm  
Couple maximum au démarrage : 9800 Nm  
Vitesse de rotation : 1.85 min<sup>-1</sup>  
Durée de vie requise pour la transmission : 10000 h  
Position de fonctionnement : horizontale  
Température ambiante 30 °C  
Milieu de travail grand

### Sélection du réducteur

Rapport requis: 1500 / 1,85 = 810  
Facteur d'application  $K_A$ : 1,25  
Couple pour la sélection du réducteur :

$$T_{2R} = 5000 \times K_A \times CS = 6125 \text{ Nm}$$

Le réducteur à sélectionner doit avoir un  $T_2 > T_{2R}$  couple de référence pour la sélection du réducteur.

Donc, aller à la page 33 et sélectionner dans la colonne  $T_N$  du tableau la valeur immédiatement plus grande de la valeur obtenue ( $T_{2R}=6125$ ), à savoir 6400 Nm; sur la même ligne dans la colonne "Type" on pourra déduire que le réducteur adapté sera de grandeur 065; dans le tableau "Caractéristiques techniques" de la page 104, sélectionner le rapport "ieff" le plus près de celui requis de  $i=810$ , qui sera  $ieff=771.8$ , donc, dans la colonne correspondant à 1500 min<sup>-1</sup> à la hauteur du rapport sélectionné, on lira un  $T_2=7348$  Nm et, par conséquent, la configuration du réducteur sera "EQ4065".

Le couple maximum du réducteur EQ4065  
 $T_{2max} = 10000 \text{ Nm} > 9500 \text{ Nm}$

La capacité thermique du réducteur EQ4065  
 $P_T = 8 \text{ kW}$ .  
Il faut tenir compte du coefficient K à cause de la température ambiante, raison pour laquelle la capacité thermique du réducteur résultera:  
 $P_{T1} = 8 \times 0.85 = 6.8 \text{ kW}$   
La vitesse en entrée étant égale à 1500 min<sup>-1</sup>, le facteur  $S = 1$

Puissance requise par l'application:  
 $P = 4900 \times 1.9 / 9550 = 0.97 \text{ kW}$   
Puisque  $6.8 \text{ kW} > 0.97 \text{ kW}$  aucun système de refroidissement auxiliaire du réducteur n'est nécessaire.

### N.B. Important

Applications qui :

- demandent des durées de fonctionnement différentes de 10000 h,
- présentent des vitesses en entrée différentes de celles indiquées au catalogue
- sont caractérisées par des cycles de fonctionnement à charges et vitesses variables
- prévoient des charges axiales sur l'arbre en entrée/sortie du réducteur, doivent être examinées séparément, à l'aide de programmes de calcul dédiés, disponibles auprès du réseau de vente Brevini Riduttori.

## 6. EJEMPLO DE SELECCIÓN DEL REDUCTOR

### Datos necesarios

**Motor principal:**  
Eléctrico 1,5 kW a 1500 min<sup>-1</sup>

**Máquina accionada:**  
cinta transportadora con alimentación no uniforme  
Servicio: continuo 10 horas diarias  
Arranques por hora: 1  
Par de funcionamiento objetivo: 4900 Nm  
Par máximo de arranque: 9800 Nm  
Velocidad de rotación: 1.85 min<sup>-1</sup>  
Vida mínima de la transmisión: 10000 h  
Posición de funcionamiento: horizontal  
Temperatura ambiente 30 °C  
Ambiente de trabajo grande

### Selección del reductor

Relación necesaria: 1500 / 1,85 = 810  
Factor de aplicación  $K_A$ : 1.25  
Par para seleccionar el reductor:

$$T_{2R} = 5000 \times K_A \times CS = 6125 \text{ Nm}$$

El reductor debe tener una  $T_2 > T_{2R}$  par de referencia para seleccionar el reductor. Ir a la pág. 33 y en la columna  $T_N$  de la tabla seleccionar el valor mayor más cercano al resultado obtenido ( $T_{2R}=6125$ ), es decir 6400

Nm; en el mismo renglón en la columna "Tipo" se encuentra el reductor idóneo para el 065; ir a la pág. 104 y en la tabla "Datos técnicos" seleccionar la relación "ieff" más cercana a  $i=810$ , que será  $ieff=771.8$ ; en la columna de 1500 min<sup>-1</sup> para la relación seleccionada aparecerá un  $T_2=7348$  Nm y el reductor tendrá una configuración "EQ4065".

Par máximo del reductor EQ4065  $T_{2max} = 10000 \text{ Nm} > 9500 \text{ Nm}$

Capacidad térmica del reductor EQ4065  
 $P_T = 8 \text{ kW}$ .  
Debido a la temperatura ambiente hay que aplicar el coeficiente K.  
La capacidad térmica del reductor será:  
 $P_{T1} = 8 \times 0.85 = 6.8 \text{ kW}$   
Como la velocidad de entrada es 1500 min<sup>-1</sup>, hay que aplicar un factor  $S = 1$

Potencia objetivo de la aplicación:  
 $P = 4900 \times 1.9 / 9550 = 0.97 \text{ kW}$   
Como  $6.8 \text{ kW} > 0.97 \text{ kW}$  no es necesario añadir sistema auxiliar de enfriamiento del reductor.

### N.B. Importante

Las aplicaciones que:

- contemplan una duración mayor o menor que 10000 horas
- tienen velocidades de entrada diferentes de las que indica el catálogo
- se caracterizan porque los ciclos de trabajo tienen cargas y velocidades variables
- contemplan la presencia de cargas axiales en el eje de entrada o de salida del reductor se deben analizar por separado, por medio de programas de cálculo especiales que pueden solicitarse a la oficina comercial de Brevini Riduttori.

## 6. EXEMPLO DE SELEÇÃO DE REDUTOR

### Dados para a seleção

**Primeiro motor:**  
Elétrico 1,5 kW a 1500 min<sup>-1</sup>

**Máquina acionada:**  
fita transportadora não uniformemente alimentada  
Serviço: contínuo de 10 horas por dia  
Número de partidas por hora: 1  
Torque de funcionamento requerido: 4900 Nm  
Torque máximo na partida: 9800 Nm  
Velocidade de rotação: 1.85 min<sup>-1</sup>  
Vida útil requerida para a transmissão: 10000 h  
Posição de funcionamento: horizontal  
Temperatura ambiente 30 °C  
Ambiente de trabalho grande

### Seleção do redutor

Relação requerida: 1500 / 1,85 = 810  
Fator de aplicação  $K_A$ : 1.25  
Torque para a seleção do redutor:

$$T_{2R} = 5000 \times K_A \times CS = 6125 \text{ Nm}$$

O redutor a ser selecionado deve ter um  $T_2 > T_{2R}$  torque de referência para a seleção do redutor.

Portanto, ir à pág. 33 e, na tabela, selecionar na coluna  $T_N$  o valor imediatamente maior que o valor obtido ( $T_{2R}=6125$ ), isto é, 6400 Nm; na mesma linha da coluna "Tipo" se lerá que o reductor idóneo terá um tamanho de 065; na pág. 104 correspondente, na tabela "Dados técnicos", selecionar a relação "ieff" mais próxima àquela solicitada de  $i=810$ , que será  $ieff=771.8$ , assim, ir à coluna equivalente a 1500 min<sup>-1</sup>. Em correspondência à relação selecionada, será lido  $T_2=7348$  Nm e, assim, o reductor terá uma configuração de "EQ4065".

O torque máximo do redutor EQ4065  $T_{2max} = 10000 \text{ Nm} > 9500 \text{ Nm}$

A capacidade térmica do redutor EQ4065  
 $P_T = 8 \text{ kW}$ .  
Em função da temperatura ambiente, é necessário considerar o coeficiente K, em função do qual a capacidade térmica do reductor tornase:  
 $P_{T1} = 8 \times 0.85 = 6.8 \text{ kW}$   
Sendo a velocidade na entrada igual a 1500 min<sup>-1</sup>, o fator  $S = 1$

Potência requerida pela aplicação:  
 $P = 4900 \times 1.9 / 9550 = 0.97 \text{ kW}$   
Sendo  $6.8 \text{ kW} > 0.97 \text{ kW}$  não é necessário nenhum sistema de arrefecimento auxiliar para o reductor.

### OBS. Importante

Aplicações que:

- requirem valores de duração diferentes das 10000 horas
- apresentem velocidades na entrada diferentes daquelas indicadas no catálogo
- são caracterizadas por ciclos de trabalho com cargas e velocidades variáveis
- prevêem a presença de cargas axiais no eixo de entrada/saída do reductor devem ser analisadas especificamente com o auxílio de programas de cálculo dedicado, disponíveis na organização de vendas da Brevini Riduttori.





**7. DATI TECNICI E TAVOLE DIMENSIONALI**  
**TECHNICAL DATA AND DIMENSIONAL DRAWINGS**  
**TECHNISCHE DATEN UND MASSBILDER**  
**CARACTERISTIQUES TECHNIQUES ET PLANCHES DES DIMENSIONS**  
**DATOS TÉCNICOS Y DISEÑOS DIMENSIONALES**  
**DADOS TÉCNICOS E TABELAS DIMENSIONAIS**



**Serie Standard / Standard Series**  
**Serie Standard / Série Standard**  
**Serie Standard / Série Standard**

Pag.  
 Page  
 Seiten  
 Page  
 Pág.  
 Pág.

Type	$i_{eff}$	$T_N$ [Nm]			
<b>010</b>	3.38 - 3282	<i>1000</i>	B40x36 DIN5482	42	<i>34</i>
<b>020</b>	3.08 - 3235	<i>2100</i>	B58x53 DIN5482	65	<i>46</i>
<b>030</b>	15.37 - 3097	<i>3800</i>	B58x53 DIN5482	65	<i>60</i>
<b>040</b>	15.37 - 3170	<i>3800</i>	B58x53 DIN5482	65	<i>72</i>
<b>045</b>	3.50 - 3301	<i>3800</i>	B58x53 DIN5482	65	<i>80</i>
<b>046</b>	3.50 - 3301	<i>3800</i>	B58x53 DIN5482	65	<i>94</i>
<b>065</b>	3.50 - 3170	<i>6400</i>	B70x64 DIN5482	65	<i>104</i>
<b>067</b>	12.25-201.0	<i>6400</i>	B70x64 DIN5482	65	<i>118</i>
<b>090</b>	4.08 - 3207	<i>9200</i>	B80x74 DIN5482	90	<i>132</i>
<b>091</b>	11.22-42.37	<i>9200</i>	B80x74 DIN5482	90	<i>146</i>
<b>150</b>	3.90-3460	<i>13000</i>	B80x74 DIN5482	100	<i>156</i>
<b>155</b>	19.50-272.7	<i>13000</i>	B80x74 DIN5482	100	<i>170</i>
<b>250</b>	4.04 - 2741	<i>20000</i>	B100x94 DIN5482	110	<i>184</i>
<b>255</b>	16.48-2744	<i>20000</i>	B100x94 DIN5482	110	<i>196</i>
<b>320</b>	19.95-245.3	<i>25000</i>	B100x94 DIN5482	110	<i>208</i>



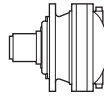

$i_{eff}$	1500			1000			500			$T_{2max}$ [Nm]	$P_T$ [kW]
	$n_2$ [rpm]	$T_2$ [Nm]	$P_2$ [kW]	$n_2$ [rpm]	$T_2$ [Nm]	$P_2$ [kW]	$n_2$ [rpm]	$T_2$ [Nm]	$P_2$ [kW]		
<b>EM 1010</b>											
3.38	444	410	19.1	296	463	14.4	148	570	8.8	1600	12
4.39	342	431	15.4	228	487	11.6	114	600	7.2	1600	
6.00	250	412	10.8	167	453	7.9	83	510	4.5	1600	
6.94	216	387	8.8	144	407	6.2	72	457	3.5	1600	
10.50	143	206	3.1	95	213	2.1	47.6	224	1.1	1600	
<b>ED 2010</b>											
11.42	131	591	8.1	88	667	6.1	43.8	821	3.8	1600	8
14.84	101	639	6.8	67	722	5.1	33.7	889	3.1	1600	
19.27	78	672	5.5	52	759	4.1	25.9	816	2.2	1600	
20.28	74	702	5.4	49.3	793	4.1	24.7	916	2.4	1600	
23.46	64	733	4.9	42.6	828	3.7	21.3	921	2.1	1600	
26.34	57	738	4.4	38.0	803	3.2	19.0	825	1.6	1600	
30.47	49.2	771	4.0	32.8	808	2.8	16.4	829	1.4	1600	
36.00	41.7	561	2.4	27.8	589	1.7	13.9	636	0.93	1600	
41.64	36.0	571	2.2	24.0	599	1.5	12.0	646	0.81	1600	
48.16	31.1	512	1.7	20.8	537	1.2	10.4	581	0.63	1600	
<b>ET 3010</b>											
65.14	23.0	918	2.2	15.4	931	1.5	7.7	952	0.77	1600	5
68.55	21.9	920	2.1	14.6	933	1.4	7.3	954	0.73	1600	
79.29	18.9	925	1.8	12.6	937	1.2	6.3	958	0.63	1600	
89.03	16.8	928	1.6	11.2	941	1.1	5.6	961	0.57	1600	
103.0	14.6	933	1.4	9.7	945	1.0	4.9	966	0.49	1600	
115.6	13.0	836	1.1	8.6	847	0.77	4.3	865	0.39	1600	
121.7	12.3	938	1.2	8.2	950	0.82	4.1	970	0.42	1600	
140.7	10.7	943	1.1	7.1	955	0.71	3.6	975	0.36	1600	
162.8	9.2	947	0.91	6.1	959	0.62	3.1	979	0.32	1600	
182.8	8.2	848	0.73	5.5	859	0.49	2.7	877	0.25	1600	
211.4	7.1	852	0.63	4.7	863	0.43	2.4	880	0.22	1600	
216.0	6.9	684	0.50	4.6	732	0.36	2.3	799	0.19	1600	
246.3	6.1	959	0.61	4.1	971	0.41	2.0	990	0.21	1600	
276.6	5.4	859	0.49	3.6	870	0.33	1.8	887	0.17	1600	
319.9	4.7	863	0.42	3.1	873	0.29	1.6	900	0.15	1600	
372.6	4.0	824	0.35	2.7	846	0.24	1.3	883	0.12	1600	
378.0	4.0	759	0.32	2.6	796	0.22	1.3	854	0.12	1600	
437.2	3.4	786	0.28	2.3	800	0.19	1.1	873	0.11	1600	
484.0	3.1	874	0.28	2.1	884	0.19	1.0	961	0.10	1600	
661.5	2.3	800	0.19	1.5	836	0.13	0.76	930	0.07	1600	
765.1	2.0	772	0.16	1.3	823	0.11	0.65	915	0.06	1600	

**1500**  
HOURS LIFE

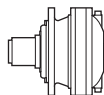

**010**

$i_{eff}$	1500			1000			500			$T_{2max}$ [Nm]	$P_T$ [kW]
	$n_2$ [rpm]	$T_2$ [Nm]	$P_2$ [kW]	$n_2$ [rpm]	$T_2$ [Nm]	$P_2$ [kW]	$n_2$ [rpm]	$T_2$ [Nm]	$P_2$ [kW]		
<b>EM 1010</b>											
3.38	444	724	33.7	296	810	25.1	148	877	13.6	1600	12
4.39	342	707	25.3	228	750	17.9	114	800	9.5	1600	
6.00	250	522	13.7	167	565	9.9	83	628	5.5	1600	
6.94	216	476	10.8	144	512	7.7	72	567	4.3	1600	
10.50	143	232	3.5	95	240	2.4	47.6	252	1.3	1600	
<b>ED 2010</b>											
11.42	131	886	12.2	88	911	8.4	43.8	944	4.3	1600	8
14.84	101	903	9.6	67	925	6.5	33.7	955	3.4	1600	
19.27	78	819	6.7	52	837	4.5	25.9	861	2.3	1600	
20.28	74	920	7.1	49.3	939	4.9	24.7	966	2.5	1600	
23.46	64	927	6.2	42.6	945	4.2	21.3	971	2.2	1600	
26.34	57	833	5.0	38.0	848	3.4	19.0	871	1.7	1600	
30.47	49.2	839	4.3	32.8	853	2.9	16.4	875	1.5	1600	
36.00	41.7	684	3.0	27.8	745	2.2	13.9	799	1.2	1600	
41.64	36.0	698	2.6	24.0	772	1.9	12.0	811	1.0	1600	
48.16	31.1	628	2.0	20.8	696	1.5	10.4	799	0.87	1600	
<b>ET 3010</b>											
65.14	23.0	969	2.3	15.4	982	1.6	7.7	1027	0.83	1600	5
68.55	21.9	971	2.2	14.6	984	1.5	7.3	1036	0.79	1600	
79.29	18.9	976	1.9	12.6	989	1.3	6.3	1060	0.70	1600	
89.03	16.8	979	1.7	11.2	993	1.2	5.6	1080	0.64	1600	
103.0	14.6	984	1.5	9.7	997	1.0	4.9	1105	0.56	1600	
115.6	13.0	882	1.2	8.6	925	0.84	4.3	1032	0.47	1600	
121.7	12.3	990	1.3	8.2	1016	0.88	4.1	1134	0.49	1600	
140.7	10.7	994	1.1	7.1	1040	0.77	3.6	1160	0.43	1600	
162.8	9.2	999	0.96	6.1	1064	0.69	3.1	1186	0.38	1600	
182.8	8.2	932	0.80	5.5	994	0.57	2.7	1107	0.32	1600	
211.4	7.1	954	0.71	4.7	1017	0.50	2.4	1132	0.28	1600	
216.0	6.9	884	0.64	4.6	942	0.46	2.3	1045	0.25	1600	
246.3	6.1	1066	0.68	4.1	1136	0.48	2.0	1263	0.27	1600	
276.6	5.4	996	0.57	3.6	1061	0.40	1.8	1178	0.22	1600	
319.9	4.7	1019	0.50	3.1	1085	0.36	1.6	1204	0.20	1600	
372.6	4.0	957	0.40	2.7	1018	0.29	1.3	1131	0.16	1600	
378.0	4.0	964	0.40	2.6	1025	0.28	1.3	1135	0.16	1600	
437.2	3.4	985	0.35	2.3	1047	0.25	1.1	1160	0.14	1600	
484.0	3.1	1086	0.35	2.1	1155	0.25	1.0	1281	0.14	1600	
661.5	2.3	1049	0.25	1.5	1113	0.18	0.76	1231	0.10	1600	
765.1	2.0	1032	0.21	1.3	1095	0.15	0.65	1211	0.08	1600	

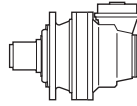

$i_{eff}$	1500			1000			500			$T_{2max}$ [Nm]	$P_T$ [kW]
	$n_2$ [rpm]	$T_2$ [Nm]	$P_2$ [kW]	$n_2$ [rpm]	$T_2$ [Nm]	$P_2$ [kW]	$n_2$ [rpm]	$T_2$ [Nm]	$P_2$ [kW]		
<b>EC 2010 - PDA 2010</b>											
10.14	148	331	5.1	99	374	3.9	49.3	460	2.4	1600	5
13.17	114	430	5.1	76	486	3.9	38.0	598	2.4	1600	
16.53	91	330	3.1	61	373	2.4	30.3	459	1.5	1600	
18.00	83	510	4.5	56	540	3.1	27.8	589	1.7	1600	
21.47	70	429	3.1	46.6	485	2.4	23.3	597	1.5	1600	
29.34	51	546	2.9	34.1	575	2.1	17.0	622	1.1	1600	
33.94	44.2	489	2.3	29.5	515	1.6	14.7	559	0.86	1600	
40.68	36.9	524	2.0	24.6	592	1.5	12.3	645	0.83	1600	
47.05	31.9	510	1.7	21.3	536	1.2	10.6	580	0.65	1600	
<b>EC 3010 - PDA 3010</b>											
34.27	43.8	821	3.8	29.2	910	2.8	14.6	933	1.4	1600	4
44.51	33.7	889	3.1	22.5	919	2.2	11.2	941	1.1	1600	
55.87	26.9	913	2.6	17.9	926	1.7	9.0	948	0.89	1600	
60.84	24.7	916	2.4	16.4	929	1.6	8.2	950	0.82	1600	
72.56	20.7	922	2.0	13.8	935	1.4	6.9	955	0.69	1600	
77.46	19.4	924	1.9	12.9	937	1.3	6.5	957	0.65	1600	
91.40	16.4	829	1.4	10.9	841	0.96	5.5	859	0.49	1600	
99.17	15.1	932	1.5	10.1	944	1.0	5.0	965	0.51	1600	
114.7	13.1	936	1.3	8.7	949	0.87	4.4	969	0.44	1600	
128.8	11.6	839	1.0	7.8	850	0.69	3.9	868	0.35	1600	
137.5	10.9	942	1.1	7.3	954	0.73	3.6	974	0.37	1600	
159.0	9.4	946	0.94	6.3	958	0.63	3.1	978	0.32	1600	
173.5	8.6	785	0.71	5.8	806	0.49	2.9	842	0.25	1600	
206.6	7.3	852	0.65	4.8	862	0.44	2.4	880	0.22	1600	
225.4	6.7	854	0.60	4.4	864	0.40	2.2	882	0.21	1600	
240.6	6.2	801	0.52	4.2	823	0.36	2.1	859	0.19	1600	
282.3	5.3	708	0.39	3.5	780	0.29	1.8	815	0.15	1600	
312.5	4.8	862	0.43	3.2	873	0.29	1.6	896	0.15	1600	
356.3	4.2	650	0.29	2.8	718	0.21	1.4	813	0.12	1600	
427.1	3.5	782	0.29	2.3	799	0.20	1.2	870	0.11	1600	
494.1	3.0	704	0.22	2.0	769	0.16	1.0	856	0.09	1600	
<b>EC 4010 - PDA 4010</b>											
150.5	10.0	945	0.99	6.6	957	0.67	3.3	976	0.34	1600	2.2
188.8	7.9	951	0.79	5.3	963	0.53	2.6	983	0.27	1600	
205.6	7.3	954	0.73	4.9	966	0.49	2.4	985	0.25	1600	
261.8	5.7	961	0.58	3.8	973	0.39	1.9	992	0.20	1600	
267.1	5.6	961	0.57	3.7	973	0.38	1.9	993	0.20	1600	
318.5	4.7	967	0.48	3.1	978	0.32	1.6	998	0.16	1600	
359.9	4.2	970	0.42	2.8	982	0.29	1.4	1001	0.15	1600	
387.7	3.9	972	0.39	2.6	984	0.27	1.3	1011	0.14	1600	
441.6	3.4	976	0.35	2.3	987	0.23	1.1	1032	0.12	1600	
503.6	3.0	980	0.31	2.0	991	0.21	0.99	1054	0.11	1600	
537.6	2.8	981	0.29	1.9	993	0.19	0.93	1065	0.10	1600	
638.8	2.3	986	0.24	1.6	998	0.16	0.78	1094	0.09	1600	
688.2	2.2	988	0.23	1.5	1000	0.15	0.73	1106	0.08	1600	
813.3	1.8	993	0.19	1.2	1019	0.13	0.61	1135	0.07	1600	
893.9	1.7	890	0.16	1.1	949	0.11	0.56	1057	0.06	1600	
1056	1.4	1001	0.15	0.95	1062	0.11	0.47	1182	0.06	1600	
1104	1.4	1003	0.14	0.91	1069	0.10	0.45	1190	0.06	1600	
1204	1.2	1017	0.13	0.83	1084	0.09	0.42	1206	0.05	1600	
1444	1.0	1046	0.11	0.69	1115	0.08	0.35	1239	0.05	1600	
1670	0.90	1070	0.10	0.60	1140	0.07	0.30	1267	0.04	1600	
1822	0.82	914	0.08	0.55	972	0.06	0.27	1080	0.03	1600	
1959	0.77	929	0.07	0.51	987	0.05	0.26	1094	0.03	1600	
2169	0.69	1023	0.07	0.46	1088	0.05	0.23	1208	0.03	1600	
2527	0.59	961	0.06	0.40	1022	0.04	0.20	1135	0.02	1600	
2964	0.51	989	0.05	0.34	1050	0.04	0.17	1163	0.02	1600	
3282	0.46	1090	0.05	0.30	1158	0.04	0.15	1284	0.02	1600	

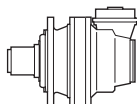

$i_{eff}$	1500			1000			500			$T_{2max}$ [Nm]	$P_T$ [kW]
	$n_2$ [rpm]	$T_2$ [Nm]	$P_2$ [kW]	$n_2$ [rpm]	$T_2$ [Nm]	$P_2$ [kW]	$n_2$ [rpm]	$T_2$ [Nm]	$P_2$ [kW]		
<b>EC 2010 - PDA 2010</b>											
10.14	148	585	9.1	99	661	6.8	49.3	814	4.2	1600	5
13.17	114	760	9.1	76	820	6.5	38.0	848	3.4	1600	
16.53	91	584	5.6	61	659	4.2	30.3	812	2.6	1600	
18.00	83	628	5.5	56	661	3.9	27.8	745	2.2	1600	
21.47	70	759	5.6	46.6	841	4.1	23.3	865	2.1	1600	
29.34	51	668	3.6	34.1	708	2.5	17.0	794	1.4	1600	
33.94	44.2	603	2.8	29.5	637	2.0	14.7	757	1.2	1600	
40.68	36.9	694	2.7	24.6	768	2.0	12.3	808	1.0	1600	
47.05	31.9	626	2.1	21.3	692	1.5	10.6	796	0.89	1600	
<b>EC 3010 - PDA 3010</b>											
34.27	43.8	944	4.3	29.2	960	2.9	14.6	984	1.5	1600	4
44.51	33.7	955	3.4	22.5	970	2.3	11.2	993	1.2	1600	
55.87	26.9	963	2.7	17.9	977	1.8	9.0	1002	0.94	1600	
60.84	24.7	966	2.5	16.4	980	1.7	8.2	1016	0.88	1600	
72.56	20.7	972	2.1	13.8	986	1.4	6.9	1045	0.76	1600	
77.46	19.4	975	2.0	12.9	988	1.3	6.5	1056	0.71	1600	
91.40	16.4	875	1.5	10.9	890	1.0	5.5	994	0.57	1600	
99.17	15.1	983	1.6	10.1	996	1.1	5.0	1098	0.58	1600	
114.7	13.1	988	1.4	8.7	1006	0.92	4.4	1123	0.51	1600	
128.8	11.6	885	1.1	7.8	941	0.77	3.9	1049	0.43	1600	
137.5	10.9	993	1.1	7.3	1036	0.79	3.6	1155	0.44	1600	
159.0	9.4	998	0.99	6.3	1061	0.70	3.1	1182	0.39	1600	
173.5	8.6	881	0.80	5.8	905	0.55	2.9	1007	0.30	1600	
206.6	7.3	951	0.72	4.8	1014	0.51	2.4	1128	0.29	1600	
225.4	6.7	964	0.67	4.4	1028	0.48	2.2	1143	0.27	1600	
240.6	6.2	900	0.59	4.2	952	0.41	2.1	1058	0.23	1600	
282.3	5.3	922	0.51	3.5	981	0.36	1.8	1088	0.20	1600	
312.5	4.8	1015	0.51	3.2	1081	0.36	1.6	1200	0.20	1600	
356.3	4.2	919	0.41	2.8	978	0.29	1.4	1084	0.16	1600	
427.1	3.5	982	0.36	2.3	1044	0.26	1.2	1156	0.14	1600	
494.1	3.0	966	0.31	2.0	1027	0.22	1.0	1137	0.12	1600	
<b>EC 4010 - PDA 4010</b>											
150.5	10.0	996	1.0	6.6	1051	0.73	3.3	1172	0.41	1600	2.2
188.8	7.9	1022	0.85	5.3	1090	0.61	2.6	1213	0.34	1600	
205.6	7.3	1036	0.79	4.9	1104	0.56	2.4	1229	0.31	1600	
261.8	5.7	1076	0.65	3.8	1147	0.46	1.9	1275	0.26	1600	
267.1	5.6	1080	0.64	3.7	1150	0.45	1.9	1279	0.25	1600	
318.5	4.7	1110	0.55	3.1	1182	0.39	1.6	1313	0.22	1600	
359.9	4.2	1131	0.49	2.8	1204	0.35	1.4	1337	0.20	1600	
387.7	3.9	1144	0.46	2.6	1218	0.33	1.3	1352	0.18	1600	
441.6	3.4	1168	0.42	2.3	1242	0.30	1.1	1378	0.16	1600	
503.6	3.0	1192	0.37	2.0	1267	0.26	0.99	1405	0.15	1600	
537.6	2.8	1204	0.35	1.9	1280	0.25	0.93	1419	0.14	1600	
638.8	2.3	1236	0.30	1.6	1313	0.22	0.78	1455	0.12	1600	
688.2	2.2	1250	0.29	1.5	1328	0.20	0.73	1471	0.11	1600	
813.3	1.8	1282	0.25	1.2	1362	0.18	0.61	1507	0.10	1600	
893.9	1.7	1192	0.21	1.1	1266	0.15	0.56	1400	0.08	1600	
1056	1.4	1333	0.20	0.95	1415	0.14	0.47	1565	0.08	1600	
1104	1.4	1341	0.19	0.91	1424	0.14	0.45	1575	0.08	1600	
1204	1.2	1359	0.18	0.83	1443	0.13	0.42	1595	0.07	1600	
1444	1.0	1396	0.15	0.69	1481	0.11	0.35	1637	0.06	1600	
1670	0.90	1426	0.13	0.60	1513	0.10	0.30	1671	0.05	1600	
1822	0.82	1218	0.11	0.55	1311	0.08	0.27	1575	0.05	1600	
1959	0.77	1229	0.10	0.51	1302	0.07	0.26	1436	0.04	1600	
2169	0.69	1358	0.10	0.46	1440	0.07	0.23	1589	0.04	1600	
2527	0.59	1283	0.08	0.40	1432	0.06	0.20	1709	0.04	1600	
2964	0.51	1304	0.07	0.34	1381	0.05	0.17	1521	0.03	1600	
3282	0.46	1442	0.07	0.30	1528	0.05	0.15	1684	0.03	1600	

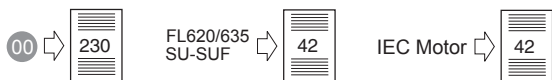
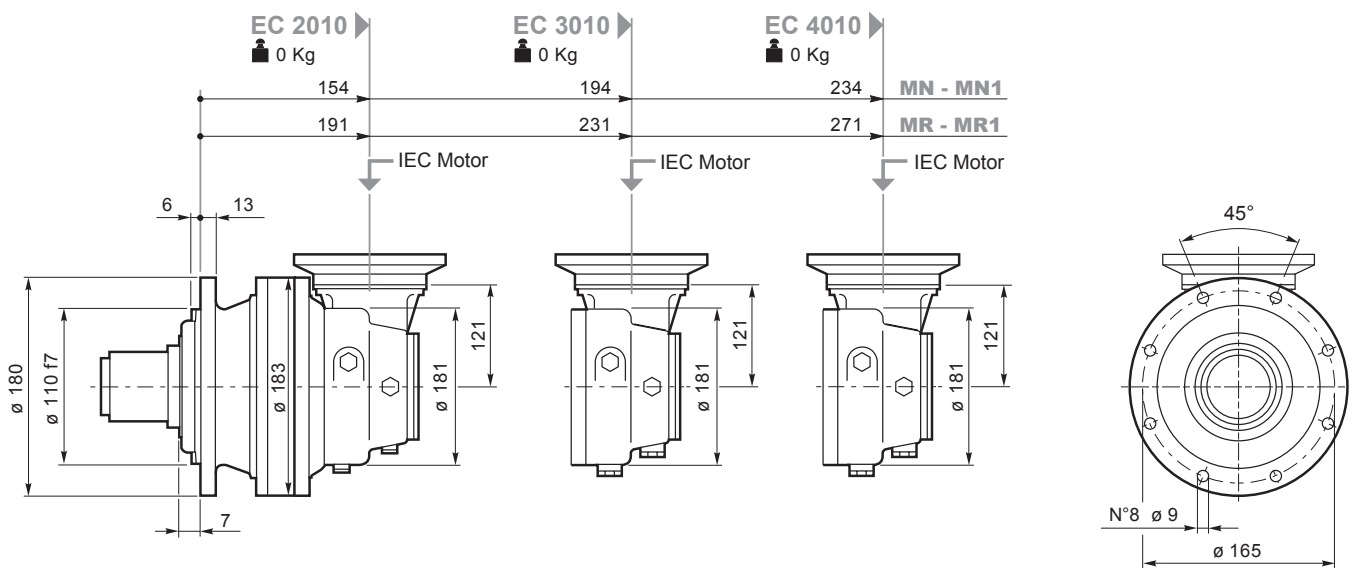
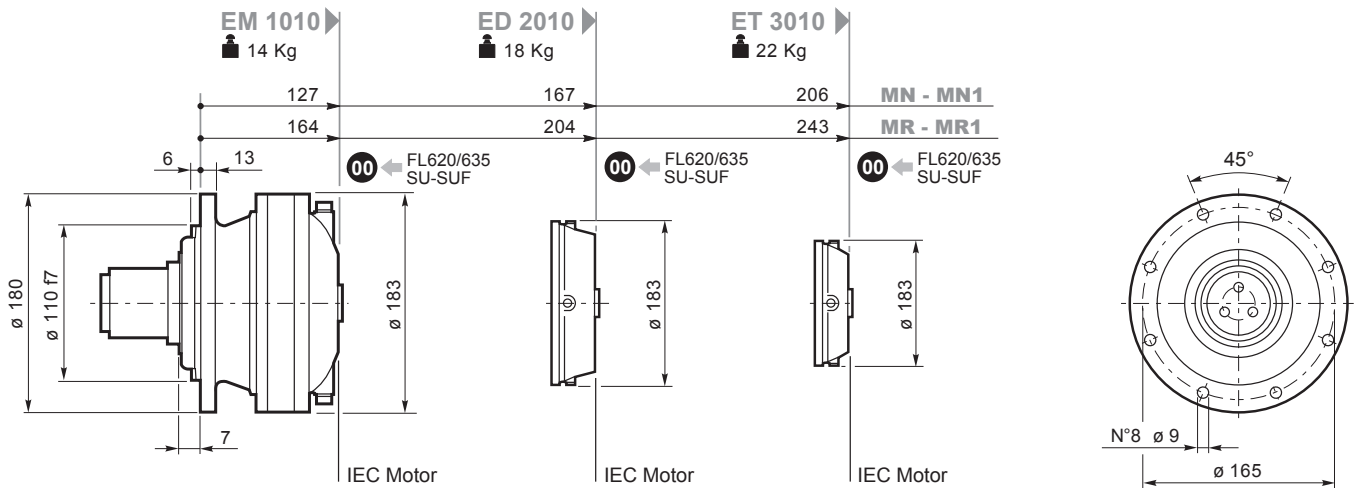
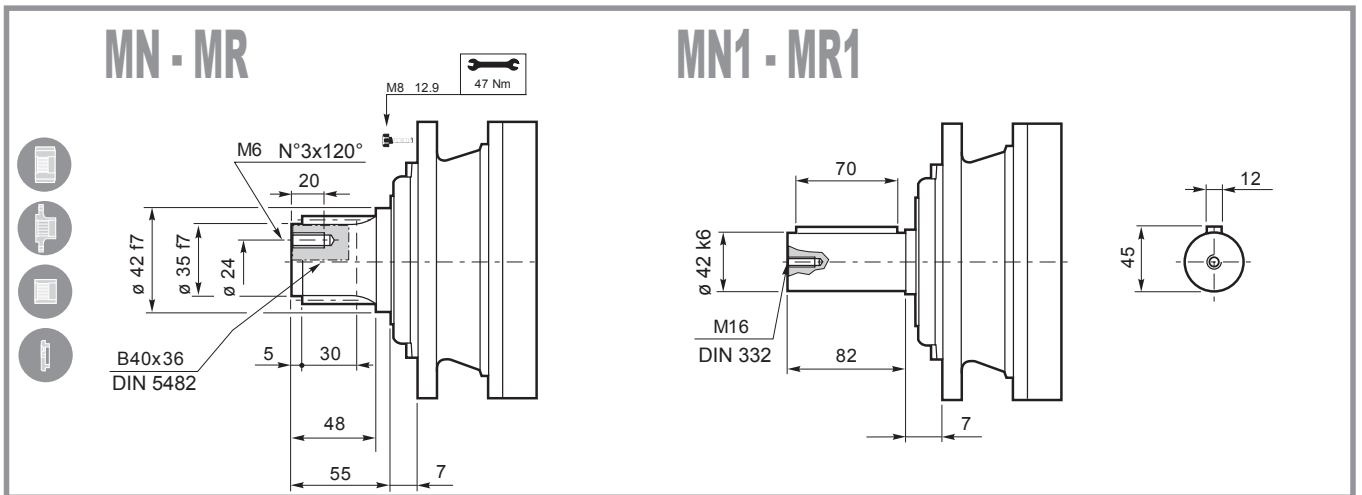

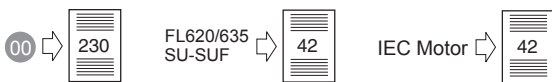
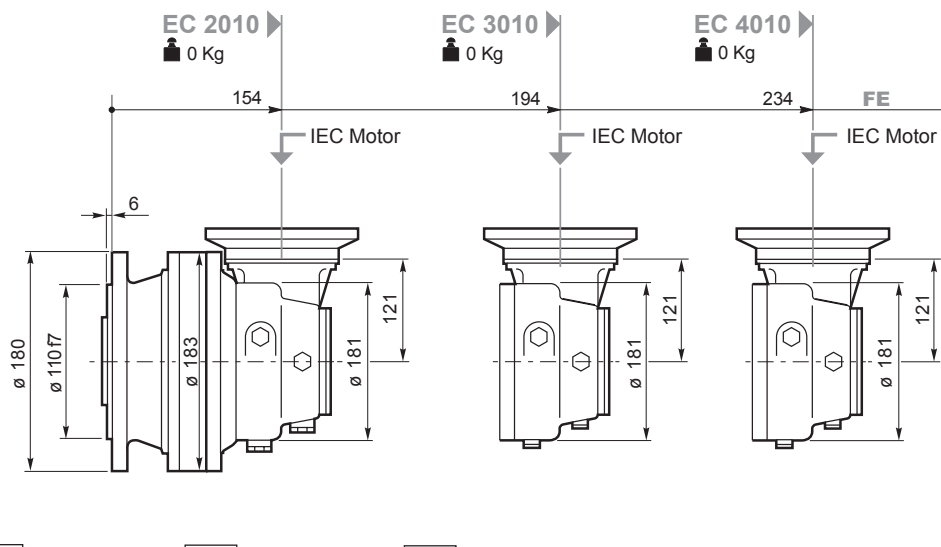
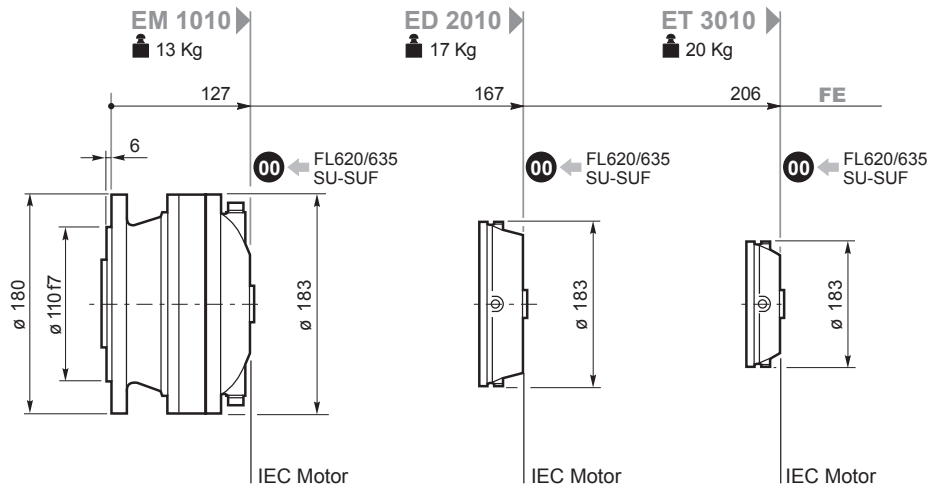
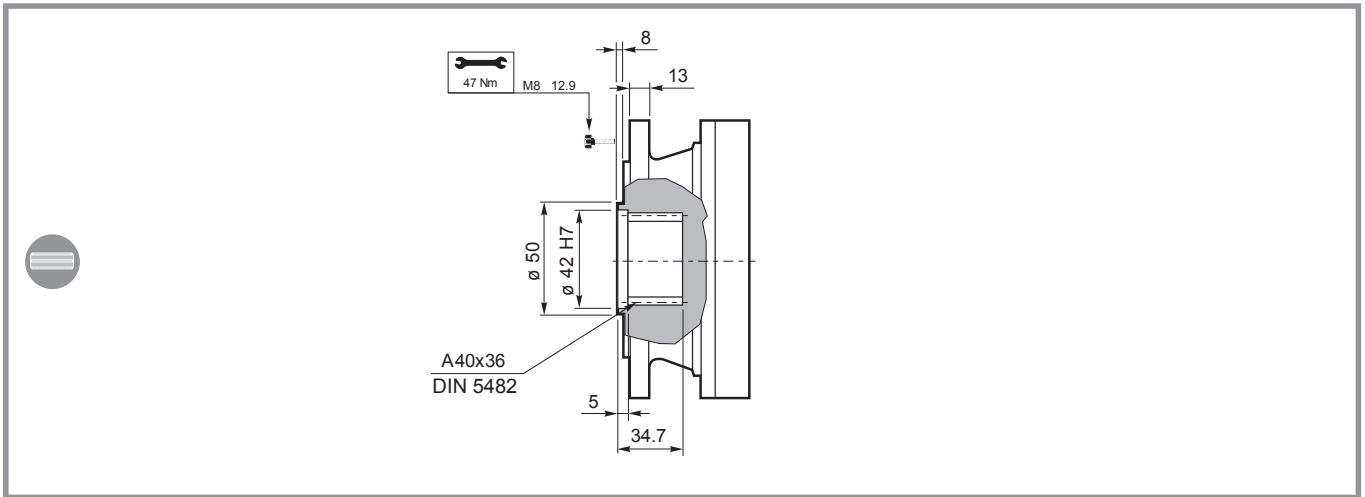

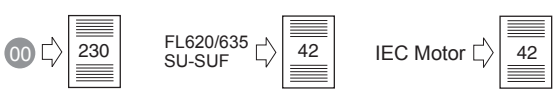
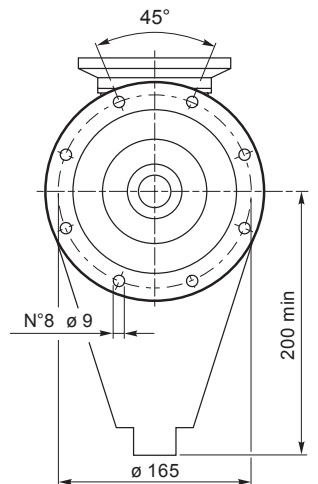
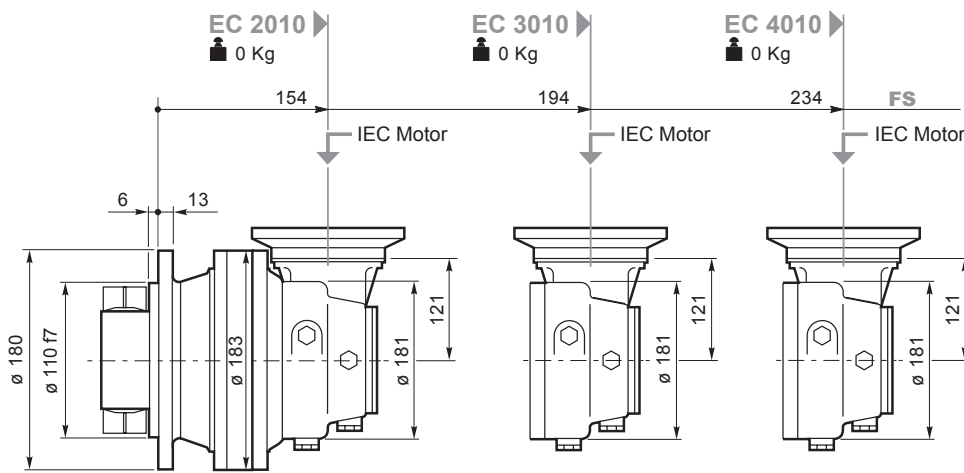
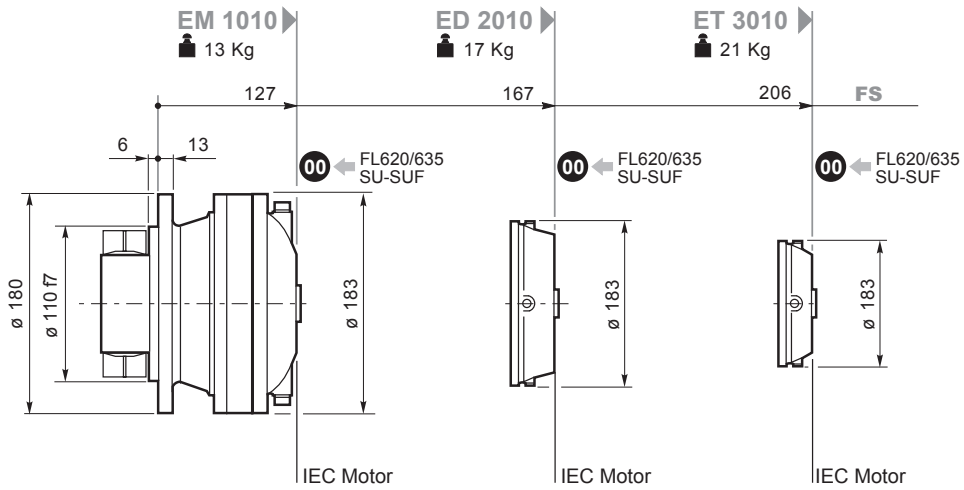
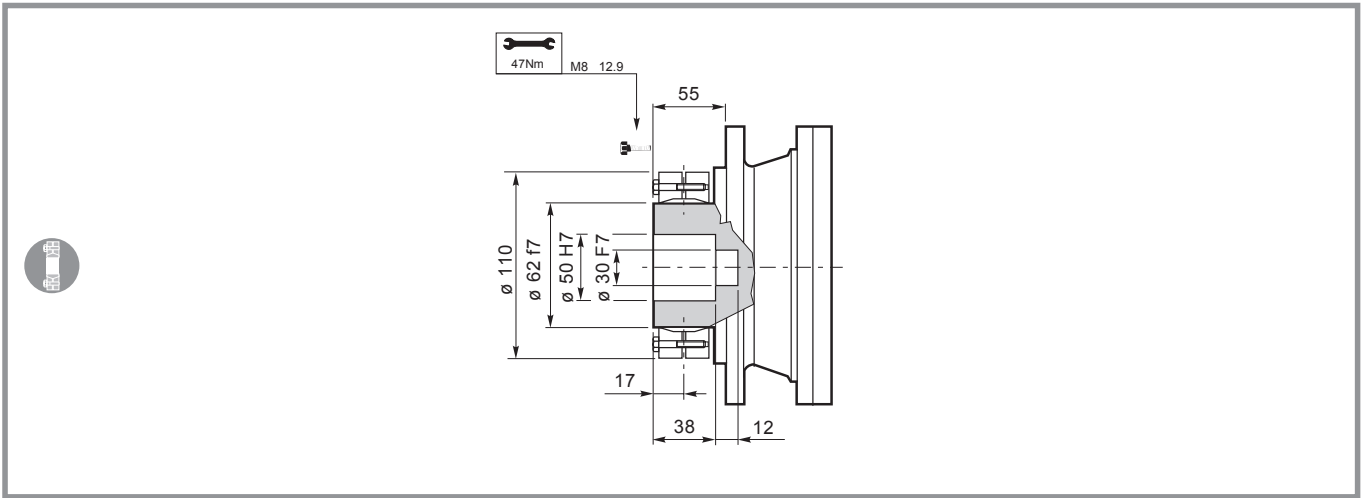

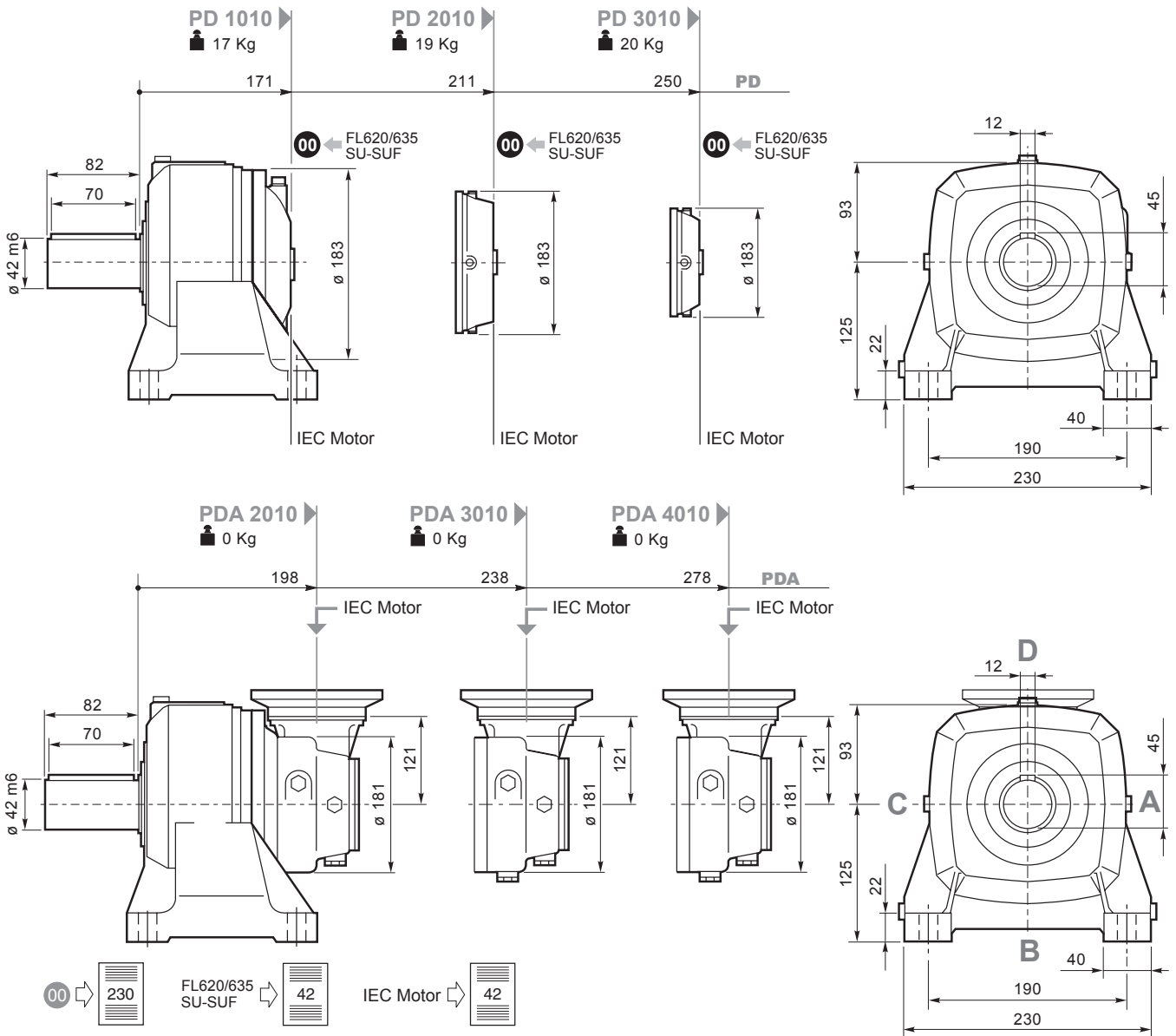
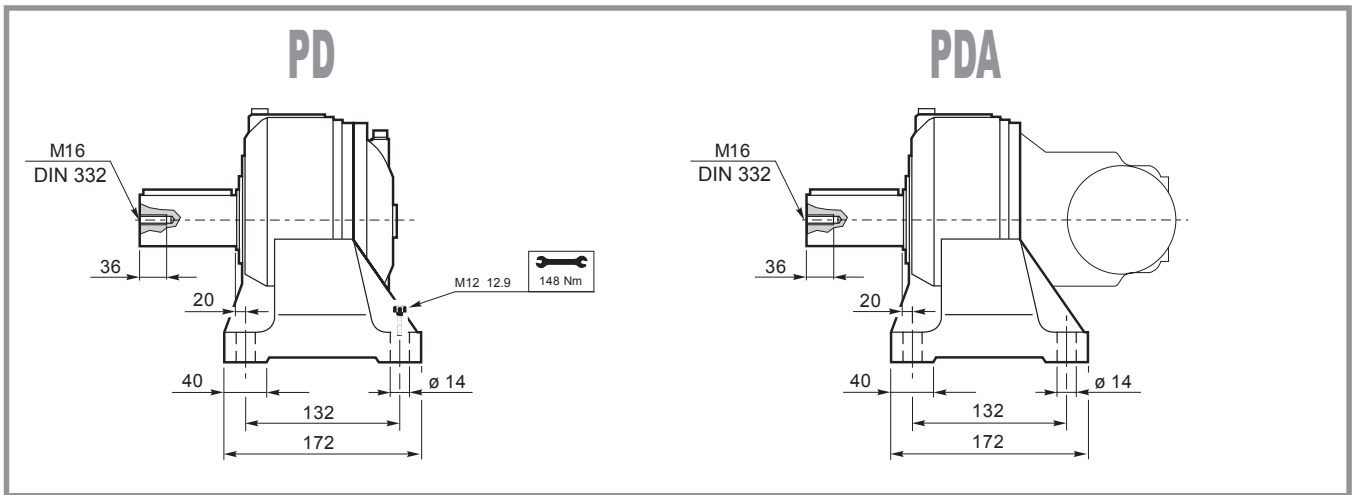



# 010

## SU2

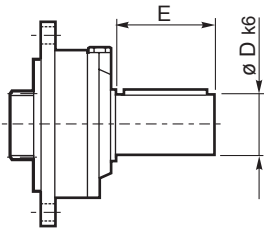

	D k6	E	Lt			
			MN-MN1 FE-FS	MR MR1	PD	
SU 2	40	58	EM1010	187	224	231
			ED2010	227	264	271
			ET3010	266	303	310

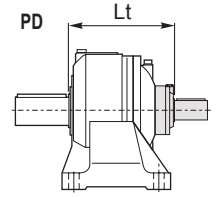
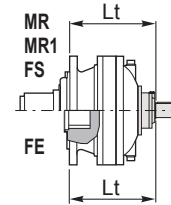

## FL620/10 - FL635/10 FL620U - FL635U

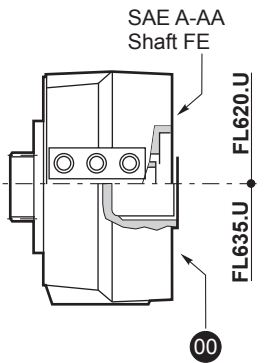

		Lt		
		MN-MN1-FE-FS	MR-MR1	PD
FL620/U	EM 1010	231.5	268.5	275.5
	ED 2010	271.5	308.5	315.5
	ET 3010	310.5	347.5	354.5
FL635U	EM 1010	218	255	262
	ED 2010	258	295	302
	ET 3010	297	334	341
FL620/10	EM 1010	190.5	227.5	234.5
	ED 2010	230.5	267.5	274
	ET 3010	269.5	306.5	320.3
FL635/10	EM 1010	172	209	172
	ED 2010	212	249	212
	ET 3010	251	288	251

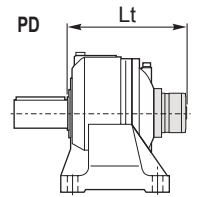
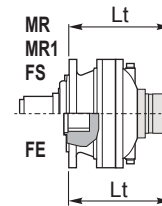

## IEC Motor

		Lt				
		IEC 63	IEC 71	IEC 80 90	IEC 100 112	IEC 132
EM 1010	MN-MN1-FE-FS	147	149	154	155	222
EM 1010	MR-MR1	184	186	191	192	259
ED 2010	MN-MN1-FE-FS	187	189	194	195	262
ED 2010	MR-MR1	224	226	231	232	299
ET 3010	MN-MN1-FE-FS	226	228	233	234	301
ET 3010	MR-MR1	263	265	270	271	338
PD 1010	PD	191	193	198	199	266
PD 2010	PD	230.5	232.5	238	239	306
PD 3010	PD	270	272	277	278	
EC 2010	MN-MN1-FE-FS-PDA	151	151	151	151	238
EC 3010	MN-MN1-FE-FS-PDA	151	151	151	151	238
EC 4010	MN-MN1-FE-FS-PDA	151	151	151	151	238

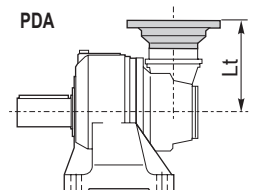
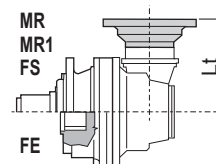
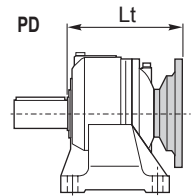
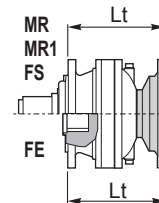





**Flangia ruota**  
Driving flange  
Radnabenflansch  
Flasque de roue  
Brida de la rueda  
Flange de roda

**FA 010**

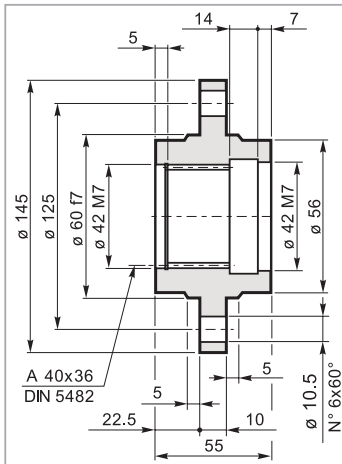

Mat. C40 UNI EN 10083  
Code: 34700231800



**Flangia ruota**  
Driving flange  
Radnabenflansch  
Flasque de roue  
Brida de la rueda  
Flange de roda

**FR 010**

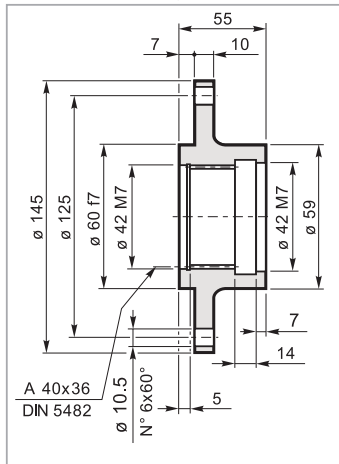

Mat. C40 UNI EN 10083  
Code: 34700331800



**Manicotto scanalato**  
Splined bush  
Keilmuffe  
Manchon cannelée  
Manguito acanalado  
Luva ranhurada

**MS 010**

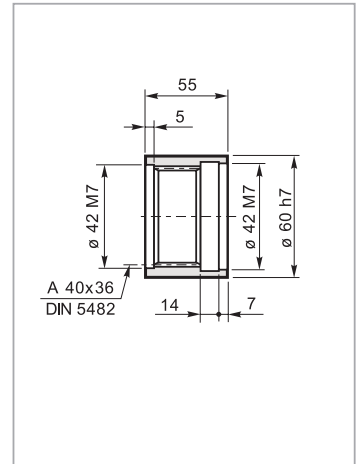

Mat. 39NiCrMo3 UNI EN 10083  
Code: 39105740800



**Rondella di fermo**  
Shaft cover  
Gegenscheibe  
Rondelle frein  
Arandela de bloqueo  
Amuela de encosto

**RDF 010**

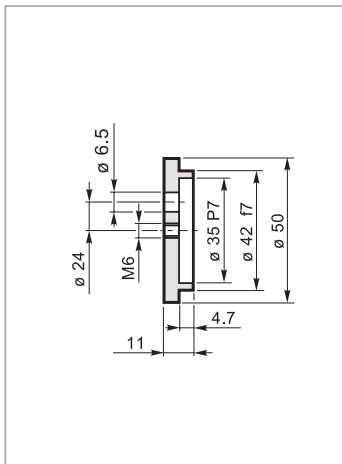

Mat. C40 UNI EN 10083  
Code: 37201840800



**Flangia ruota**  
Driving flange  
Radnabenflansch  
Barre cannelée  
Barra acanalada  
Barra ranhurada

**BS 010**

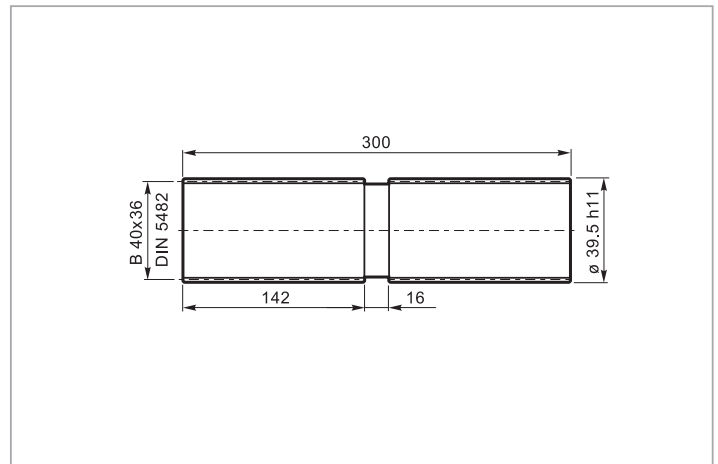

Mat. 39NiCrMo3 UNI EN 10083  
Code: 39126730100

Carichi radiali sugli alberi uscita / Radial loads on output shafts  
 Radiallasten auf de Abtriebswellen / Charges radiales sur les arbres de sortie  
 Cargas sobre los ejes de salida / Cargas radiais nos eixos de saida

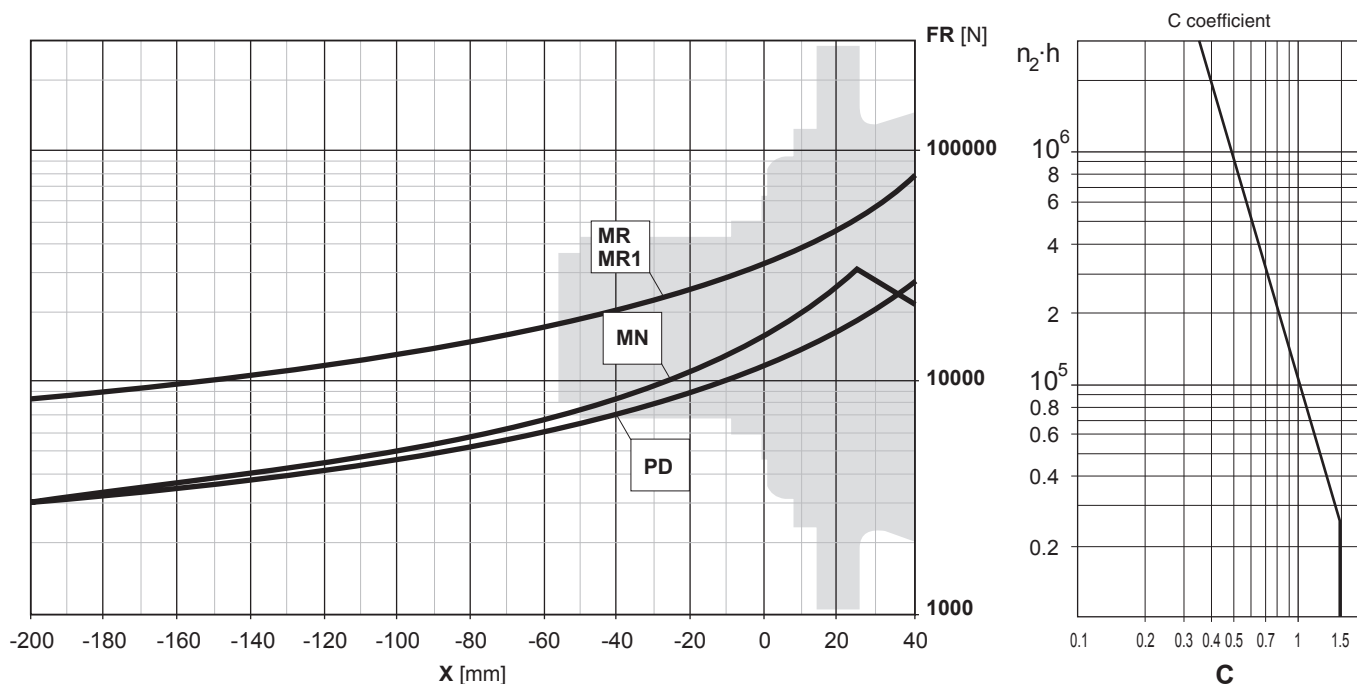

Carichi assiali / Axial loads / Axialkräfte / Charges axiales / Cargas axiales / Forças axiais

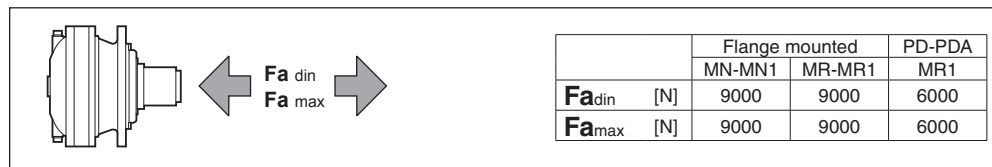

Carichi radiali sugli alberi entrata / Radial loads on input shafts  
 Radiallasten auf de Antriebswellen / Charges radiales sur les arbres d'entrée  
 Cargas sobre los ejes de entrada / Cargas radiais nos eixos de entrada

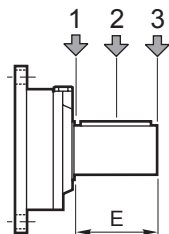

Type	E	$Fr$ [N]					
		$n_1 \cdot h = 10^7$			$n_1 \cdot h = 10^8$		
		1	2	3	1	2	3
SU2	58	3000	2000	1500	1400	1000	700

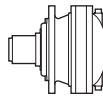

$i_{eff}$	1500			1000			500			$T_{2max}$ [Nm]	$P_T$ [kW]
	$n_2$ [rpm]	$T_2$ [Nm]	$P_2$ [kW]	$n_2$ [rpm]	$T_2$ [Nm]	$P_2$ [kW]	$n_2$ [rpm]	$T_2$ [Nm]	$P_2$ [kW]		
<b>EM 1020</b>											
3.08	487	888	45.3	325	1003	34.1	162	1235	21.0	2800	20
3.50	429	972	43.6	286	1098	32.9	143	1351	20.2	2800	
4.13	363	1005	38.2	242	1135	28.8	121	1397	17.7	2800	
5.17	290	1045	31.8	193	1159	23.5	97	1287	13.0	2800	
6.00	250	1001	26.2	167	1077	18.8	83	1187	10.4	2800	
7.25	207	863	18.7	138	924	13.3	69	1015	7.3	2800	
<b>ED 2020</b>											
10.41	144	1263	19.1	96	1427	14.4	48.0	1756	8.8	2800	12
11.83	127	1401	18.6	85	1582	14.0	42.3	1948	8.6	2800	
13.52	111	1329	15.4	74	1501	11.6	37.0	1848	7.2	2800	
15.37	98	1510	15.4	65	1705	11.6	32.5	2036	6.9	2800	
18.13	83	1566	13.6	55	1715	9.9	27.6	1840	5.3	2800	
21.00	71	1445	10.8	47.6	1585	7.9	23.8	1787	4.5	2800	
22.70	66	1348	9.3	44.1	1411	6.5	22.0	1515	3.5	2800	
24.78	61	1697	10.8	40.4	1772	7.5	20.2	1895	4.0	2800	
28.66	52	1600	8.8	34.9	1683	6.2	17.4	1890	3.5	2800	
31.02	48.4	1397	7.1	32.2	1458	4.9	16.1	1561	2.6	2800	
35.88	41.8	1419	6.2	27.9	1480	4.3	13.9	1582	2.3	2800	
41.64	36.0	1305	4.9	24.0	1360	3.4	12.0	1453	1.8	2800	
50.32	29.8	1116	3.5	19.9	1164	2.4	9.9	1246	1.3	2800	
<b>ET 3020</b>											
59.36	25.3	2071	5.5	16.8	2276	4.0	8.4	2514	2.2	2800	
61.28	24.5	1861	4.8	16.3	1933	3.3	8.2	2078	1.8	2800	
70.98	21.1	2121	4.7	14.1	2201	3.2	7.0	2471	1.8	2800	
82.10	18.3	2150	4.1	12.2	2229	2.8	6.1	2545	1.6	2800	
92.19	16.3	2172	3.7	10.8	2259	2.6	5.4	2606	1.5	2800	
106.6	14.1	2201	3.2	9.4	2329	2.3	4.7	2683	1.3	2800	
108.8	13.8	1963	2.8	9.2	2035	2.0	4.6	2341	1.1	2800	
126.0	11.9	1963	2.4	7.9	2062	1.7	4.0	2228	0.93	2800	
145.7	10.3	1999	2.2	6.9	2097	1.5	3.4	2263	0.81	2800	
161.3	9.3	2333	2.3	6.2	2536	1.6	3.1	2912	0.95	2800	
172.0	8.7	2049	1.9	5.8	2231	1.4	2.9	2567	0.78	2800	
198.9	7.5	2113	1.7	5.0	2221	1.2	2.5	2401	0.63	2800	
220.5	6.8	2099	1.5	4.5	2196	1.0	2.3	2364	0.56	2800	
260.2	5.8	2235	1.3	3.8	2428	0.98	1.9	2785	0.56	2800	
289.0	5.2	1583	0.86	3.5	1727	0.63	1.7	1994	0.36	2800	
325.7	4.6	1833	0.88	3.1	1995	0.64	1.5	2297	0.37	2800	
<b>EQ 4020</b>											
360.4	4.2	2748	1.2	2.8	2976	0.87	1.4	3157	0.46	2800	4
404.7	3.7	2812	1.1	2.5	2966	0.77	1.2	3029	0.39	2800	
468.1	3.2	2893	0.97	2.1	2979	0.67	1.1	3042	0.34	2800	
502.5	3.0	2554	0.80	2.0	2766	0.58	0.99	3063	0.32	2800	
569.8	2.6	3006	0.83	1.8	3120	0.57	0.88	3358	0.31	2800	
639.8	2.3	2971	0.73	1.6	3008	0.49	0.78	3070	0.25	2800	
708.2	2.1	2980	0.66	1.4	3017	0.45	0.71	3079	0.23	2800	
835.7	1.8	2822	0.53	1.2	2988	0.37	0.60	3279	0.21	2800	
892.1	1.7	2828	0.50	1.1	3014	0.35	0.56	3303	0.19	2800	
1032	1.5	2870	0.44	0.97	3074	0.31	0.48	3317	0.17	2800	
1120	1.3	3022	0.42	0.89	3058	0.29	0.45	3150	0.15	2800	
1323	1.1	2659	0.32	0.76	2789	0.22	0.38	2989	0.12	2800	
1380	1.1	2641	0.30	0.72	2920	0.22	0.36	3328	0.13	2800	
1561	0.96	3077	0.31	0.64	3249	0.22	0.32	3527	0.12	2800	
1806	0.83	3138	0.27	0.55	3304	0.19	0.28	3607	0.11	2800	
1999	0.75	3181	0.25	0.50	3358	0.18	0.25	3680	0.10	2800	
2315	0.65	2801	0.19	0.43	2927	0.13	0.22	3258	0.07	2800	
2615	0.57	2783	0.17	0.38	3004	0.12	0.19	3417	0.07	2800	
2732	0.55	3305	0.19	0.37	3454	0.13	0.18	3834	0.07	2800	
3160	0.47	3189	0.16	0.32	3399	0.11	0.16	3782	0.06	2800	

**1500**  
HOURS LIFE

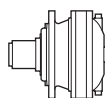

**020**

$i_{eff}$	1500			1000			500			$T_{2max}$ [Nm]	$P_T$ [kW]	
	$n_2$ [rpm]	$T_2$ [Nm]	$P_2$ [kW]	$n_2$ [rpm]	$T_2$ [Nm]	$P_2$ [kW]	$n_2$ [rpm]	$T_2$ [Nm]	$P_2$ [kW]			
<b>EM 1020</b>												
3.08	487	1570	80	325	1773	60	162	2117	36.0	2800	20	
3.50	429	1683	76	286	1837	55	143	2045	30.6	2800		
4.13	363	1549	59	242	1678	42.6	121	1857	23.5	2800		
5.17	290	1304	39.6	193	1401	28.4	97	1539	15.6	2800		
6.00	250	1219	31.9	167	1301	22.7	83	1421	12.4	2800		
7.25	207	1058	22.9	138	1123	16.2	69	1223	8.8	2800		
<b>ED 2020</b>												
10.41	144	2151	32.5	96	2258	22.7	48.0	2616	13.2	2800	12	
11.83	127	2077	27.6	85	2177	19.3	42.3	2502	11.1	2800		
13.52	111	2180	25.3	74	2311	17.9	37.0	2464	9.5	2800		
15.37	98	2142	21.9	65	2275	15.5	32.5	2644	9.0	2800		
18.13	83	1942	16.8	55	2046	11.8	27.6	2378	6.9	2800		
21.00	71	1829	13.7	47.6	1980	9.9	23.8	2200	5.5	2800		
22.70	66	1608	11.1	44.1	1679	7.7	22.0	1956	4.5	2800		
24.78	61	2008	12.7	40.4	2193	9.3	20.2	2537	5.4	2800		
28.66	52	1967	10.8	34.9	2118	7.7	17.4	2344	4.3	2800		
31.02	48.4	1661	8.4	32.2	1801	6.1	16.1	2089	3.5	2800		
35.88	41.8	1699	7.4	27.9	1860	5.4	13.9	2153	3.1	2800		
41.64	36.0	1557	5.9	24.0	1704	4.3	12.0	1974	2.5	2800		
50.32	29.8	1336	4.2	19.9	1464	3.0	9.9	1703	1.8	2800		
<b>ET 3020</b>												
59.36	25.3	2525	6.7	16.8	2578	4.5	8.4	2654	2.3	2800		8
61.28	24.5	2438	6.3	16.3	2648	4.5	8.2	2974	2.5	2800		
70.98	21.1	2888	6.4	14.1	3098	4.6	7.0	3271	2.4	2800		
82.10	18.3	2973	5.7	12.2	3110	4.0	6.1	3336	2.1	2800		
92.19	16.3	2917	5.0	10.8	2971	3.4	5.4	3050	1.7	2800		
106.6	14.1	2937	4.3	9.4	2988	2.9	4.7	3065	1.5	2800		
108.8	13.8	2739	4.0	9.2	2926	2.8	4.6	3215	1.5	2800		
126.0	11.9	2395	3.0	7.9	2610	2.2	4.0	2799	1.2	2800		
145.7	10.3	2444	2.6	6.9	2705	1.9	3.4	2840	1.0	2800		
161.3	9.3	2989	2.9	6.2	3035	2.0	3.1	3121	1.0	2800		
172.0	8.7	2884	2.6	5.8	3115	1.9	2.9	3351	1.0	2800		
198.9	7.5	2594	2.0	5.0	2878	1.5	2.5	3300	0.87	2800		
220.5	6.8	2711	1.9	4.5	2787	1.3	2.3	3033	0.72	2800		
260.2	5.8	3118	1.9	3.8	3288	1.3	1.9	3579	0.72	2800		
289.0	5.2	2337	1.3	3.5	2529	0.92	1.7	2885	0.52	2800		
325.7	4.6	2683	1.3	3.1	2900	0.93	1.5	3301	0.53	2800		
<b>EQ 4020</b>												
360.4	4.2	3446	1.5	2.8	3491	1.0	1.4	3868	0.56	2800	4	
404.7	3.7	3089	1.2	2.5	3238	0.84	1.2	3612	0.47	2800		
468.1	3.2	3104	1.0	2.1	3314	0.74	1.1	3694	0.41	2800		
502.5	3.0	3406	1.1	2.0	3595	0.75	0.99	3937	0.41	2800		
569.8	2.6	3497	0.96	1.8	3727	0.69	0.88	4152	0.38	2800		
639.8	2.3	3265	0.80	1.6	3482	0.57	0.78	3876	0.32	2800		
708.2	2.1	3319	0.74	1.4	3538	0.52	0.71	3936	0.29	2800		
835.7	1.8	3644	0.69	1.2	3843	0.48	0.60	4206	0.26	2800		
892.1	1.7	3654	0.64	1.1	3876	0.46	0.56	4242	0.25	2800		
1032	1.5	3738	0.57	0.97	3950	0.40	0.48	4322	0.22	2800		
1120	1.3	3567	0.50	0.89	3797	0.36	0.45	4217	0.20	2800		
1323	1.1	3375	0.40	0.76	3588	0.28	0.38	3975	0.16	2800		
1380	1.1	3762	0.43	0.72	4001	0.30	0.36	4436	0.17	2800		
1561	0.96	3955	0.40	0.64	4169	0.28	0.32	4558	0.15	2800		
1806	0.83	4031	0.35	0.55	4248	0.25	0.28	4644	0.14	2800		
1999	0.75	4084	0.32	0.50	4304	0.23	0.25	4705	0.12	2800		
2315	0.65	3671	0.25	0.43	3898	0.18	0.22	4310	0.10	2800		
2615	0.57	3948	0.24	0.38	4217	0.17	0.19	4607	0.09	2800		
2732	0.55	4253	0.25	0.37	4481	0.17	0.18	4896	0.09	2800		
3160	0.47	4262	0.21	0.32	4525	0.15	0.16	4988	0.08	2800		

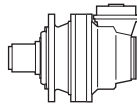

$i_{eff}$	1500			1000			500			$T_{2max}$ [Nm]	$P_T$ [kW]
	$n_2$ [rpm]	$T_2$ [Nm]	$P_2$ [kW]	$n_2$ [rpm]	$T_2$ [Nm]	$P_2$ [kW]	$n_2$ [rpm]	$T_2$ [Nm]	$P_2$ [kW]		

**EC 2020 - PDA 2020**

10.50	143	1351	20.2	95	1526	15.2	47.6	1879	9.4	2800
12.39	121	1397	17.7	81	1578	13.3	40.4	1772	7.5	2800
14.23	105	1392	15.4	70	1572	11.6	35.1	1936	7.1	2800
16.17	93	1538	14.9	62	1737	11.3	30.9	2047	6.6	2800
18.00	83	1187	10.4	56	1245	7.2	27.8	1340	3.9	2800
19.08	79	1590	13.1	52	1724	9.5	26.2	1849	5.1	2800
21.75	69	1015	7.3	46.0	1064	5.1	23.0	1147	2.8	2800
23.89	63	1357	8.9	41.9	1419	6.2	20.9	1522	3.3	2800
27.72	54	1249	7.1	36.1	1305	4.9	18.0	1398	2.6	2800
33.50	44.8	1067	5.0	29.9	1116	3.5	14.9	1198	1.9	2800

8

**EC 3020 - PDA 3020**

46.09	32.5	1507	5.1	21.7	1702	3.9	10.8	2095	2.4	2800
52.42	28.6	1476	4.4	19.1	1536	3.1	9.5	1639	1.6	2800
57.85	25.9	1157	3.1	17.3	1307	2.4	8.6	1609	1.5	2800
63.00	23.8	1787	4.5	15.9	1892	3.1	7.9	2062	1.7	2800
68.26	22.0	1366	3.1	14.6	1542	2.4	7.3	1899	1.5	2800
75.13	20.0	1503	3.1	13.3	1698	2.4	6.7	2090	1.5	2800
88.66	16.9	1774	3.1	11.3	1998	2.4	5.6	2245	1.3	2800
102.7	14.6	1913	2.9	9.7	2013	2.1	4.9	2179	1.1	2800
111.0	13.5	1587	2.2	9.0	1647	1.6	4.5	1841	0.87	2800
121.2	12.4	1982	2.6	8.3	2073	1.8	4.1	2393	1.0	2800
142.4	10.5	1835	2.0	7.0	2073	1.5	3.5	2258	0.83	2800
168.0	8.9	2040	1.9	6.0	2220	1.4	3.0	2555	0.80	2800
175.5	8.5	1655	1.5	5.7	1751	1.0	2.8	2026	0.61	2800
194.3	7.7	2103	1.7	5.1	2215	1.2	2.6	2395	0.65	2800
210.3	7.1	1682	1.3	4.8	1820	0.91	2.4	2103	0.52	2800
243.3	6.2	1722	1.1	4.1	1877	0.81	2.1	2166	0.47	2800
282.3	5.3	1575	0.88	3.5	1718	0.64	1.8	1985	0.37	2800
308.1	4.9	1393	0.71	3.2	1430	0.49	1.6	1495	0.25	2800
368.1	4.1	1226	0.52	2.7	1259	0.36	1.4	1315	0.19	2800
427.1	3.5	1423	0.52	2.3	1461	0.36	1.2	1526	0.19	2800
516.1	2.9	1478	0.45	1.9	1613	0.33	0.97	1844	0.19	2800

5

**EC 4020 - PDA 4020**

276.6	5.4	2606	1.5	3.6	2825	1.1	1.8	2995	0.57	2800
319.9	4.7	2683	1.3	3.1	2907	0.95	1.6	3008	0.49	2800
347.1	4.3	2727	1.2	2.9	2954	0.89	1.4	3141	0.47	2800
401.5	3.7	2807	1.1	2.5	3039	0.79	1.2	3203	0.42	2800
450.8	3.3	2872	1.0	2.2	2976	0.69	1.1	3039	0.35	2800
521.4	2.9	2952	0.89	1.9	2989	0.60	0.96	3052	0.31	2800
556.6	2.7	2993	0.85	1.8	3118	0.59	0.90	3347	0.32	2800
625.0	2.4	2969	0.75	1.6	3006	0.50	0.80	3068	0.26	2800
712.7	2.1	2382	0.53	1.4	2526	0.37	0.70	2795	0.21	2800
788.9	1.9	2990	0.60	1.3	3027	0.40	0.63	3089	0.21	2800
853.1	1.8	2496	0.46	1.2	2604	0.32	0.59	3072	0.19	2800
988.1	1.5	2478	0.39	1.0	2732	0.29	0.51	2855	0.15	2800
1094	1.4	3020	0.43	0.91	3056	0.29	0.46	3139	0.15	2800
1247	1.2	2275	0.29	0.80	2513	0.21	0.40	2848	0.12	2800
1495	1.0	2737	0.29	0.67	2798	0.20	0.33	3046	0.11	2800
1616	0.93	2536	0.25	0.62	2742	0.18	0.31	3126	0.10	2800
1729	0.87	2466	0.22	0.58	2693	0.16	0.29	2997	0.09	2800
2040	0.74	2909	0.22	0.49	3178	0.16	0.25	3537	0.09	2800
2208	0.68	2694	0.19	0.45	2910	0.14	0.23	3312	0.08	2800
2554	0.59	2770	0.17	0.39	2991	0.12	0.20	3402	0.07	2800
2787	0.54	1399	0.08	0.36	1487	0.06	0.18	1652	0.03	2800
3235	0.46	1623	0.08	0.31	1726	0.06	0.15	1918	0.03	2800

3

Tutti i rapporti evidenziati (es. 10.50) hanno dimensioni particolari della coppia conica in certe versioni; vedere tavole dimensionali.

All ratios grey highlighted (ex. 10.50) have specific dimensions of the bevel gear set in some versions; see dimensional tables.

Alle mit (es. 10.50) gekennzeichneten Übersetzungen haben in bestimmten Versionen besondere Dimensionen des Kegelradtriebs. Siehe auch Dimensionstabellen.

Les rapports repérés par (es. 10.50) ont des dimensions de couple conique particulières. Voir les tableaux dimensionnels.

Todas las relaciones indicadas con (es. 10.50) tienen dimensiones particulares del par cónico según las versiones; ver las tablas de dimensión.

As relações marcadas com (es. 10.50) têm dimensões particulares da engrenagem cônica em certas versões; vide tabelas dimensionais.



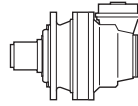

$i_{eff}$	1500			1000			500			$T_{2max}$ [Nm]	$P_T$ [kW]
	$n_2$ [rpm]	$T_2$ [Nm]	$P_2$ [kW]	$n_2$ [rpm]	$T_2$ [Nm]	$P_2$ [kW]	$n_2$ [rpm]	$T_2$ [Nm]	$P_2$ [kW]		

**EC 2020 - PDA 2020**

10.50	143	2045	30.6	95	2149	21.4	47.6	2439	12.2	2800
12.39	121	1857	23.5	81	1947	16.5	40.4	2193	9.3	2800
14.23	105	2235	24.7	70	2405	17.7	35.1	2794	10.3	2800
16.17	93	2155	20.9	62	2302	14.9	30.9	2672	8.7	2800
18.00	83	1421	12.4	56	1485	8.6	27.8	1651	4.8	2800
19.08	79	1953	16.1	52	2070	11.4	26.2	2404	6.6	2800
21.75	69	1223	8.8	46.0	1278	6.2	23.0	1417	3.4	2800
23.89	63	1616	10.6	41.9	1699	7.4	20.9	1978	4.3	2800
27.72	54	1489	8.4	36.1	1557	5.9	18.0	1813	3.4	2800
33.50	44.8	1282	6.0	29.9	1336	4.2	14.9	1560	2.4	2800

8

**EC 3020 - PDA 3020**

46.09	32.5	2644	9.0	21.7	2873	6.5	10.8	2971	3.4	2800
52.42	28.6	1849	5.5	19.1	2017	4.0	9.5	2325	2.3	2800
57.85	25.9	2045	5.6	17.3	2309	4.2	8.6	2843	2.6	2800
63.00	23.8	2200	5.5	15.9	2316	3.9	7.9	2610	2.2	2800
68.26	22.0	2413	5.6	14.6	2706	4.2	7.3	3019	2.3	2800
75.13	20.0	2656	5.6	13.3	2944	4.1	6.7	3028	2.1	2800
88.66	16.9	2629	4.7	11.3	2849	3.4	5.6	3128	1.8	2800
102.7	14.6	2339	3.6	9.7	2479	2.5	4.9	2780	1.4	2800
111.0	13.5	2167	3.1	9.0	2352	2.2	4.5	2695	1.3	2800
121.2	12.4	2760	3.6	8.3	2926	2.5	4.1	3262	1.4	2800
142.4	10.5	2430	2.7	7.0	2690	2.0	3.5	2829	1.0	2800
168.0	8.9	2867	2.7	6.0	3105	1.9	3.0	3339	1.0	2800
175.5	8.5	2377	2.1	5.7	2575	1.5	2.8	2941	0.88	2800
194.3	7.7	2587	2.1	5.1	2861	1.5	2.6	3288	0.89	2800
210.3	7.1	2464	1.8	4.8	2667	1.3	2.4	3043	0.76	2800
243.3	6.2	2535	1.6	4.1	2743	1.2	2.1	3127	0.67	2800
282.3	5.3	2326	1.3	3.5	2517	0.93	1.8	2872	0.53	2800
308.1	4.9	1565	0.80	3.2	1607	0.55	1.6	1788	0.30	2800
368.1	4.1	1378	0.59	2.7	1456	0.41	1.4	1619	0.23	2800
427.1	3.5	1599	0.59	2.3	1690	0.41	1.2	1879	0.23	2800
516.1	2.9	1932	0.59	1.9	2042	0.41	0.97	2271	0.23	2800

5

**EC 4020 - PDA 4020**

276.6	5.4	3050	1.7	3.6	3091	1.2	1.8	3403	0.64	2800
319.9	4.7	3065	1.5	3.1	3116	1.0	1.6	3482	0.57	2800
347.1	4.3	3442	1.6	2.9	3487	1.1	1.4	3845	0.58	2800
401.5	3.7	3458	1.4	2.5	3524	0.92	1.2	3933	0.51	2800
450.8	3.3	3099	1.1	2.2	3294	0.77	1.1	3673	0.43	2800
521.4	2.9	3159	0.95	1.9	3371	0.68	0.96	3756	0.38	2800
556.6	2.7	3494	0.99	1.8	3713	0.70	0.90	4137	0.39	2800
625.0	2.4	3253	0.82	1.6	3469	0.58	0.80	3862	0.32	2800
712.7	2.1	3068	0.68	1.4	3267	0.48	0.70	3628	0.27	2800
788.9	1.9	3376	0.67	1.3	3598	0.48	0.63	4001	0.27	2800
853.1	1.8	3492	0.64	1.2	3718	0.46	0.59	4130	0.25	2800
988.1	1.5	3228	0.51	1.0	3434	0.36	0.51	3808	0.20	2800
1094	1.4	3554	0.51	0.91	3784	0.36	0.46	4202	0.20	2800
1247	1.2	3219	0.41	0.80	3423	0.29	0.40	3795	0.16	2800
1495	1.0	3438	0.36	0.67	3654	0.26	0.33	4046	0.14	2800
1616	0.93	3620	0.35	0.62	3895	0.25	0.31	4333	0.14	2800
1729	0.87	3383	0.31	0.58	3595	0.22	0.29	3980	0.12	2800
2040	0.74	3992	0.31	0.49	4242	0.22	0.25	4697	0.12	2800
2208	0.68	3830	0.27	0.45	4119	0.20	0.23	4509	0.11	2800
2554	0.59	3932	0.24	0.39	4204	0.17	0.20	4593	0.09	2800
2787	0.54	1864	0.11	0.36	2006	0.08	0.18	2409	0.05	2800
3235	0.46	2163	0.11	0.31	2328	0.08	0.15	2796	0.05	2800

3

Tutti i rapporti evidenziati (es. 10.50) hanno dimensioni particolari della coppia conica in certe versioni; vedere tavole dimensionali.

All ratios grey highlighted (ex. 10.50) have specific dimensions of the bevel gear set in some versions; see dimensional tables.

Alle mit (es. 10.50) gekennzeichneten Übersetzungen haben in bestimmten Versionen besondere Dimensionen des Kegelradtriebs. Siehe auch Dimensionstabellen.

Les rapports repérés par (es. 10.50) ont des dimensions de couple conique particulières. Voir les tableaux dimensionnels.

Todas las relaciones indicadas con (es. 10.50) tienen dimensiones particulares del par cónico según las versiones; ver las tablas de dimensión.

As relações marcadas com (es. 10.50) têm dimensões particulares da engrenagem cônica em certas versões; vide tabelas dimensionais.





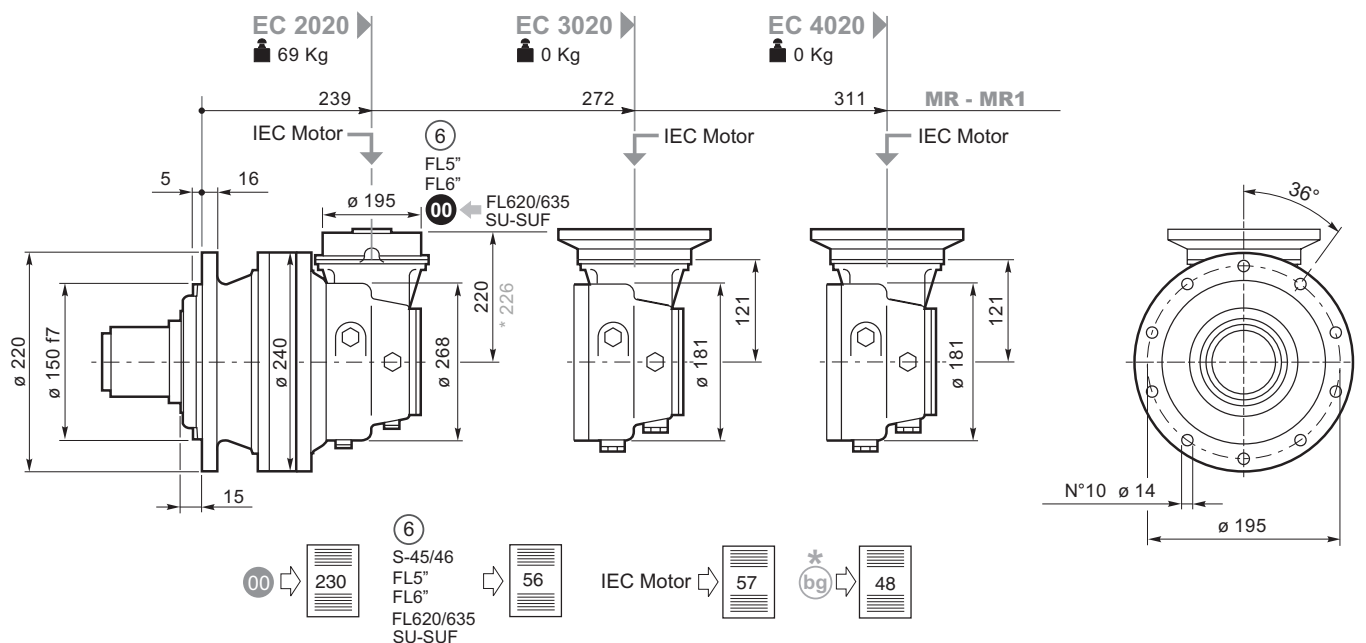
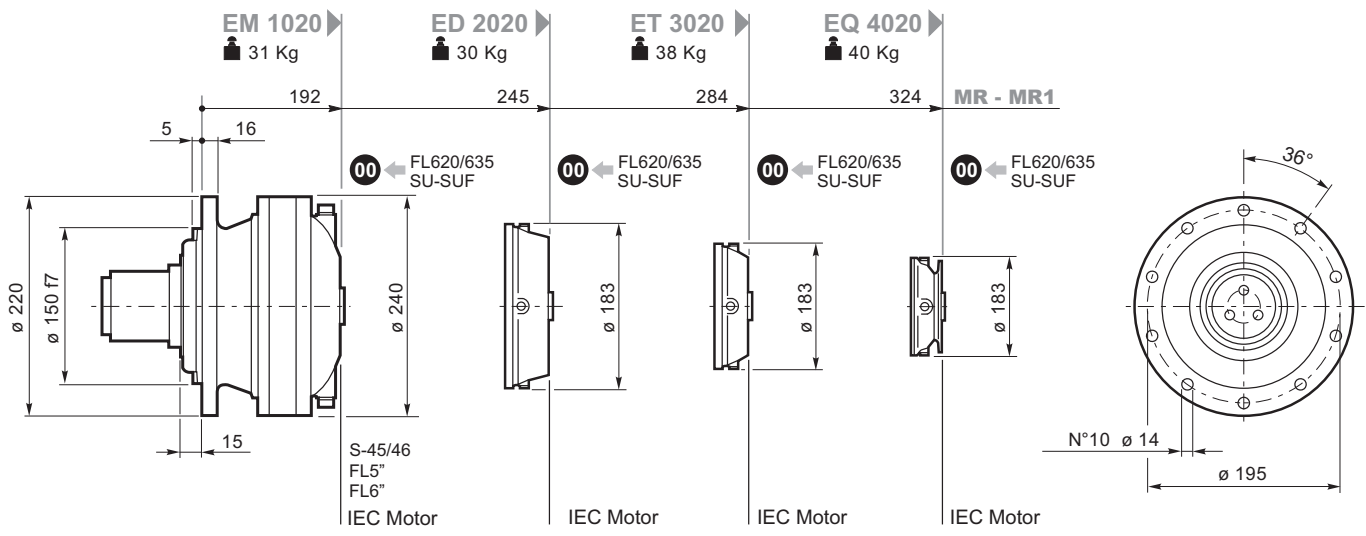
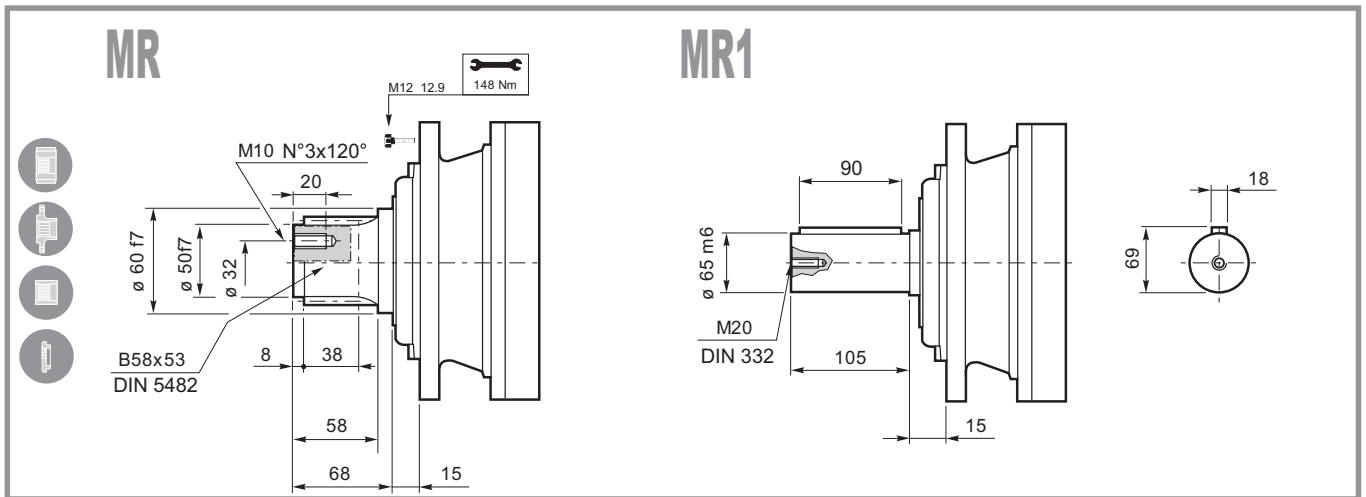

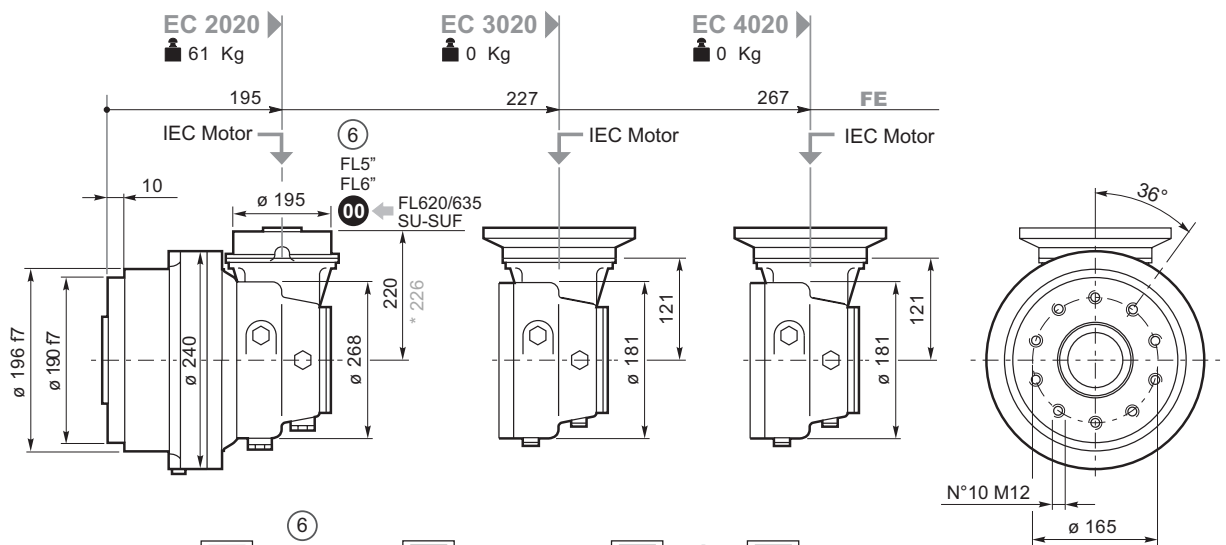
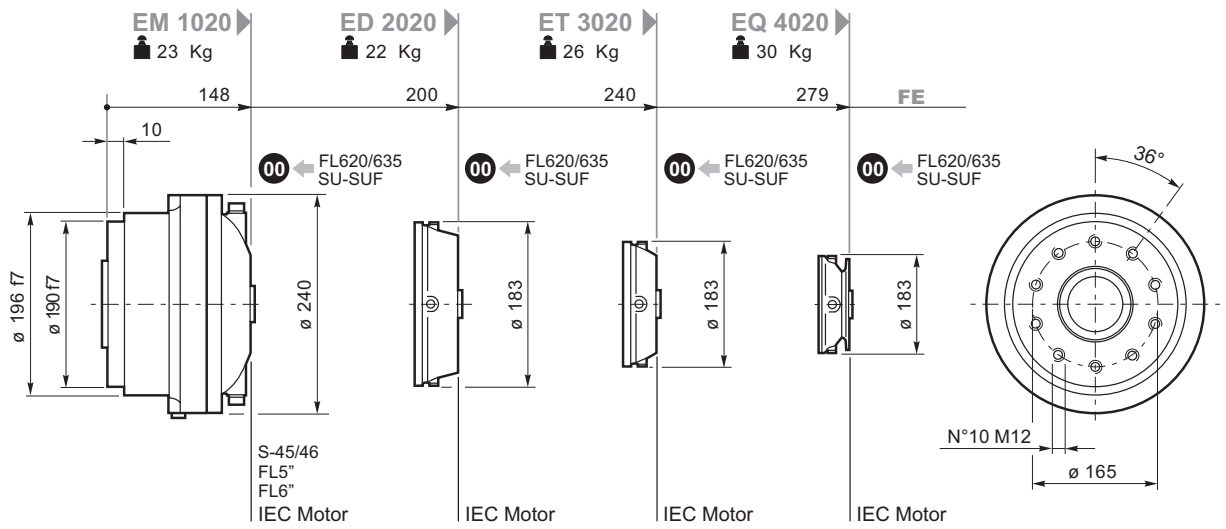
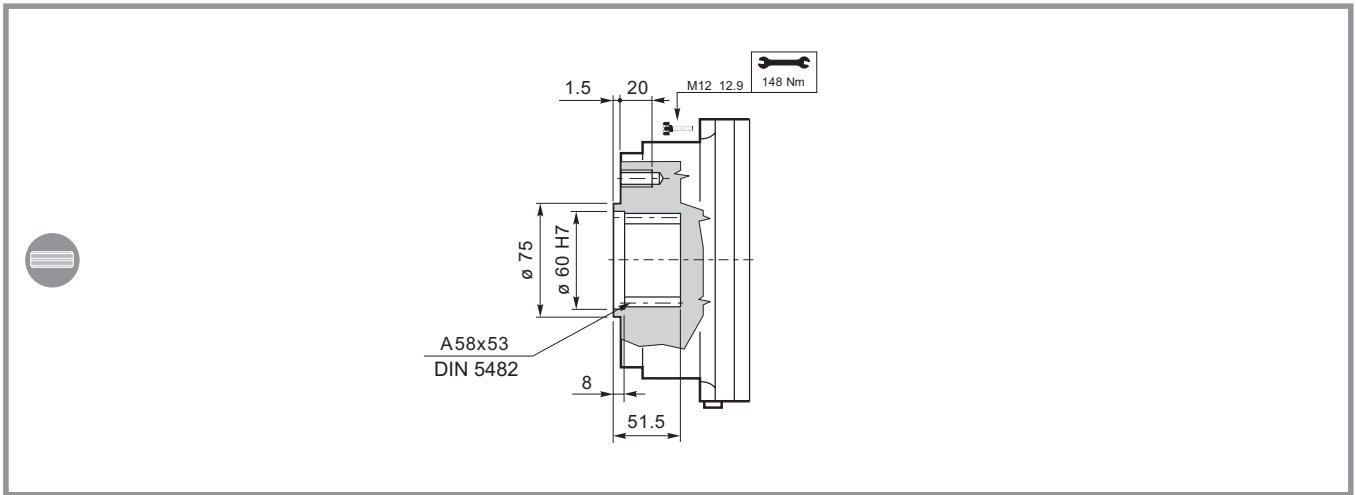

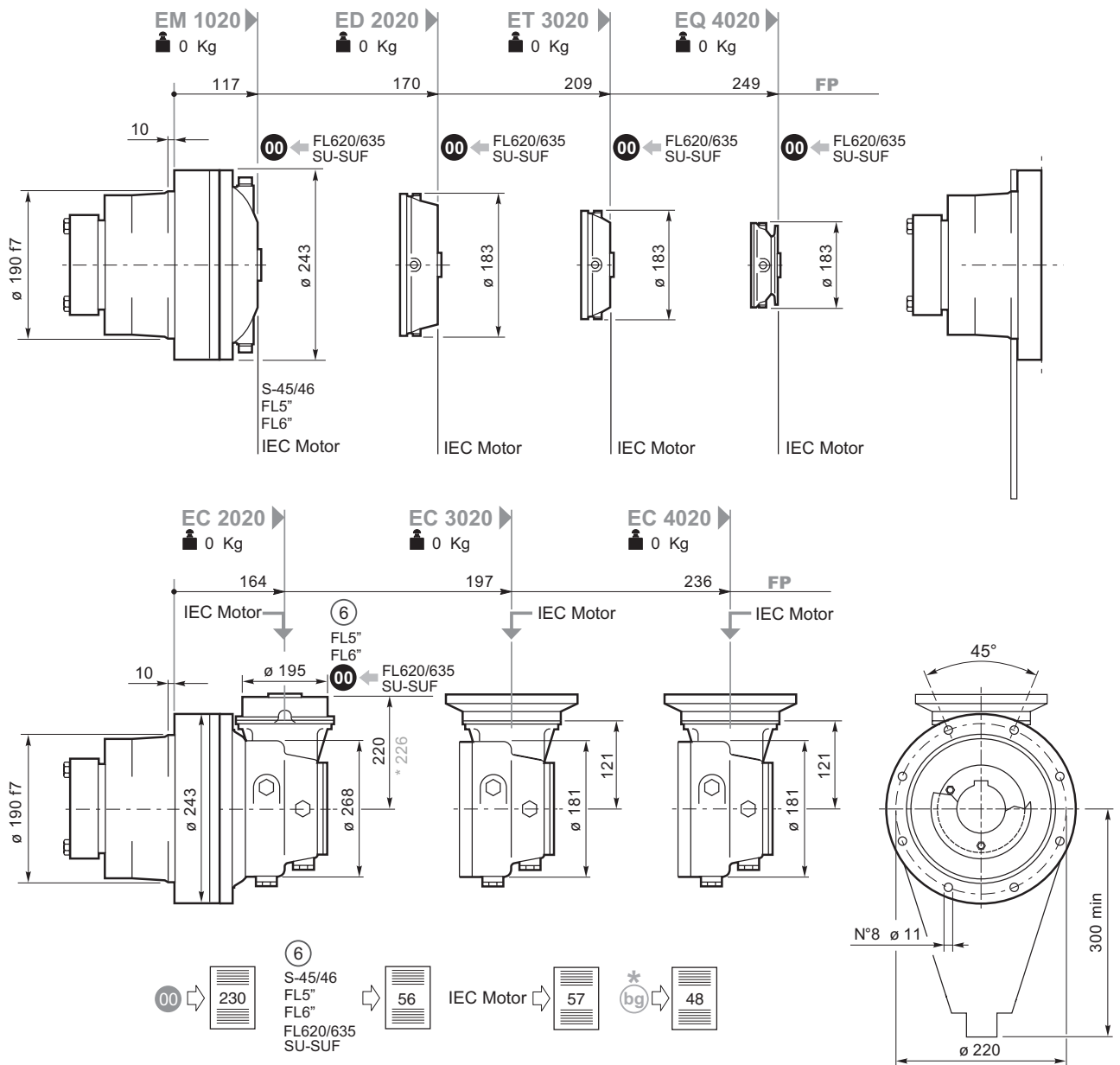
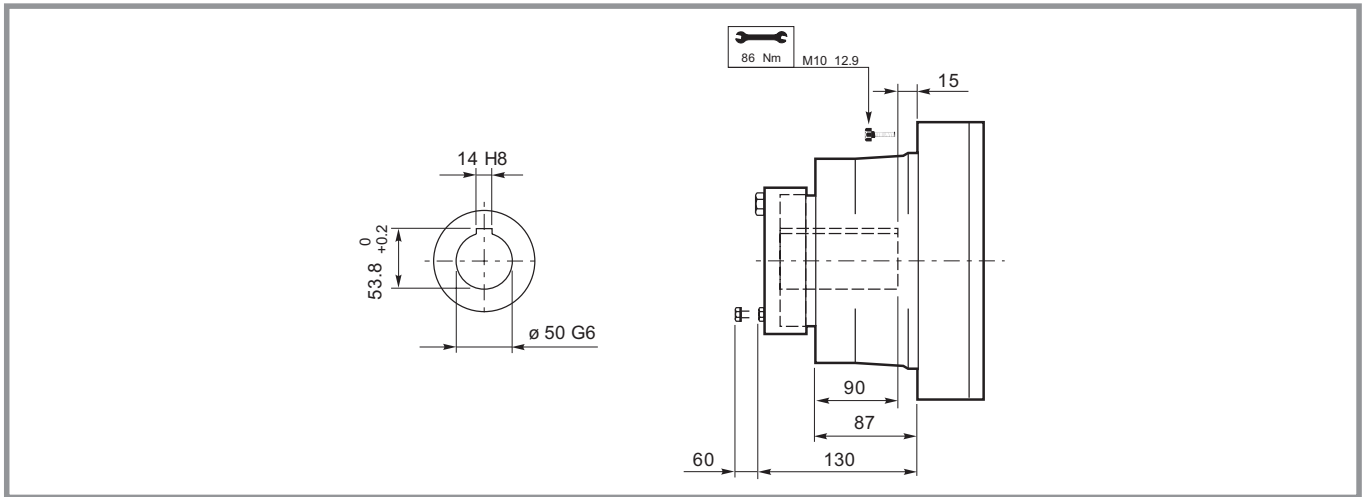

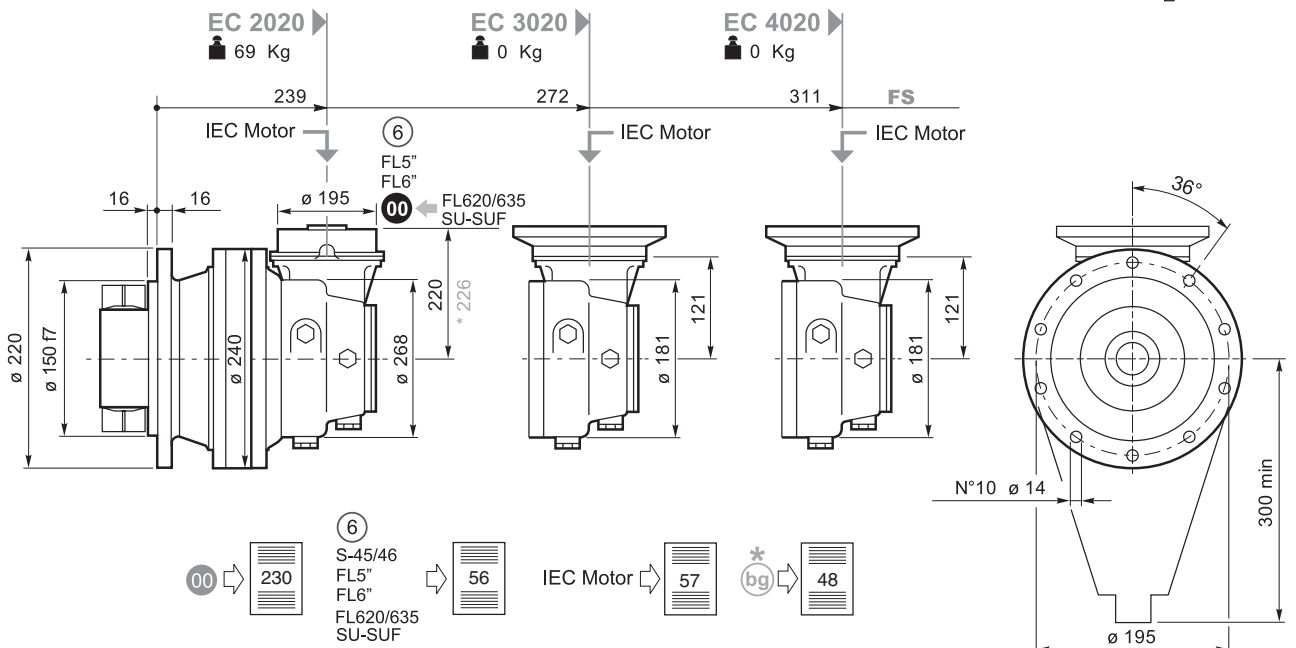
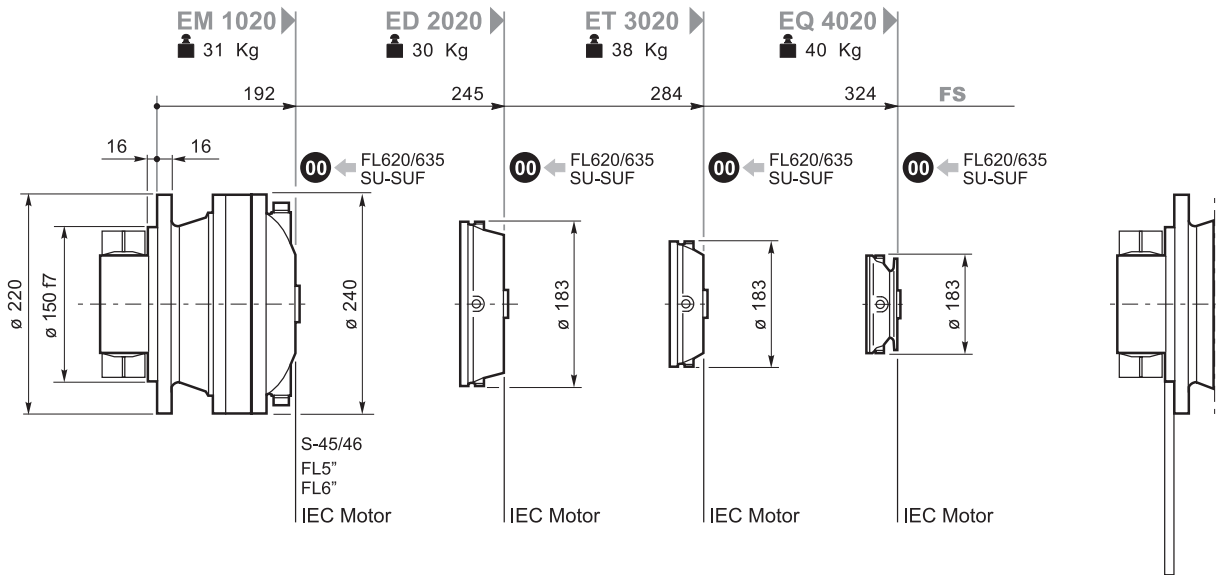
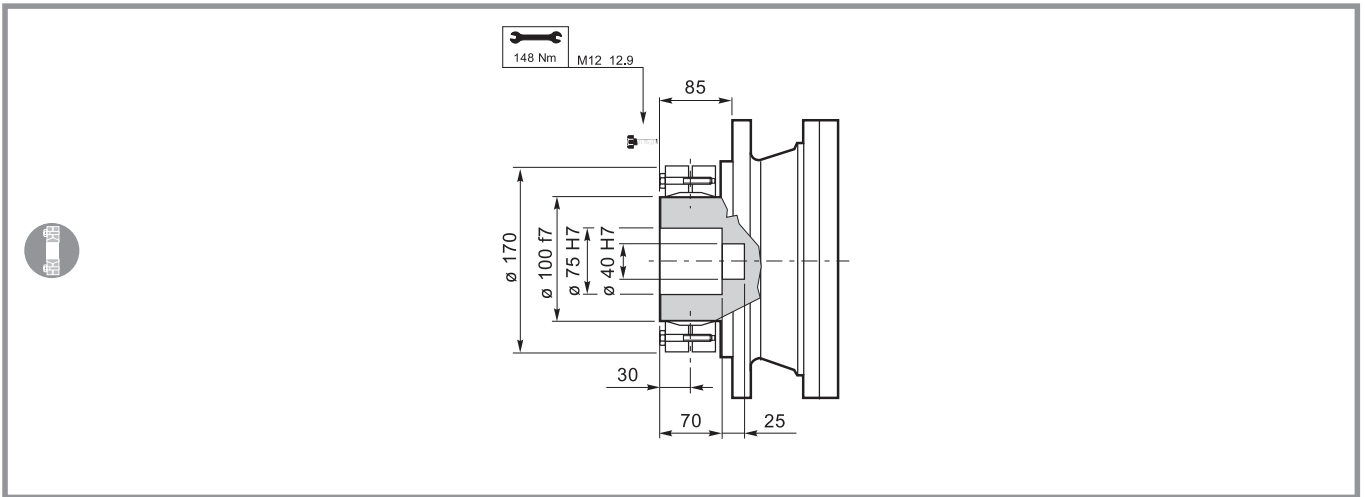

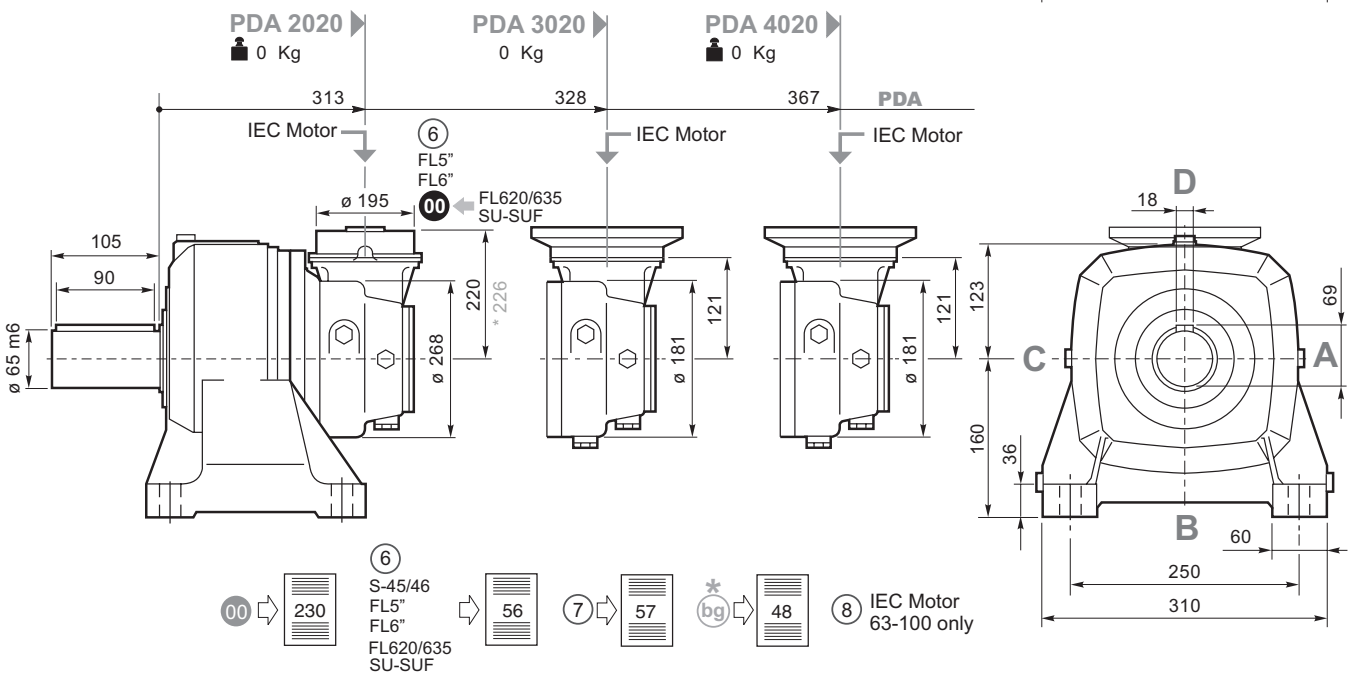
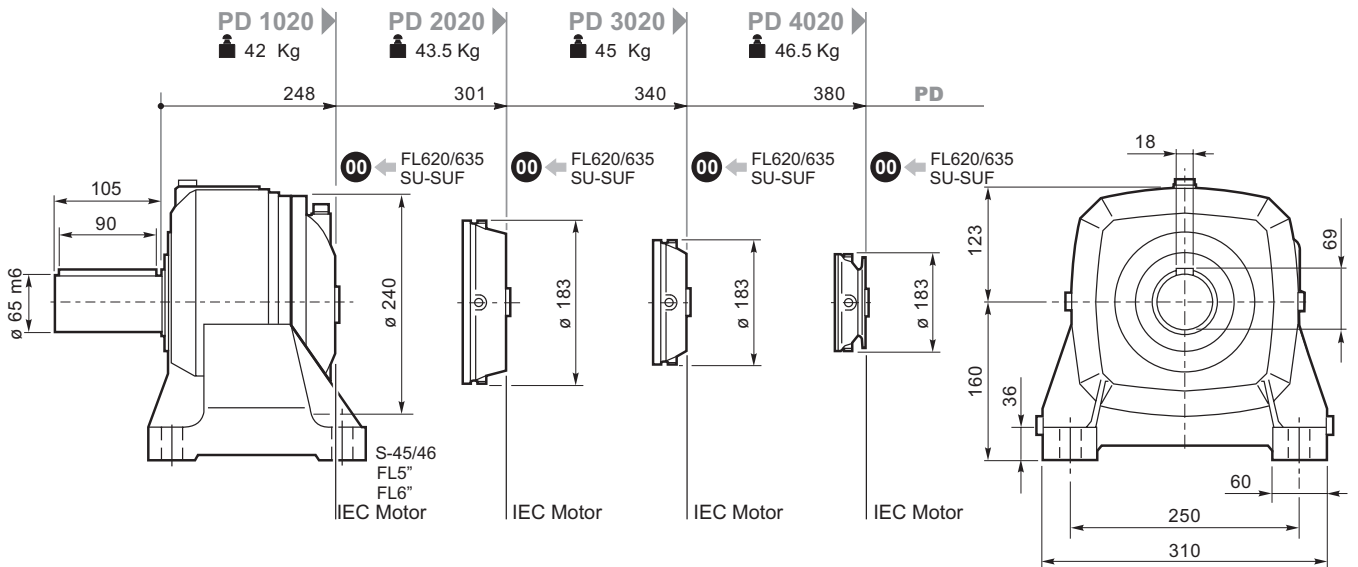
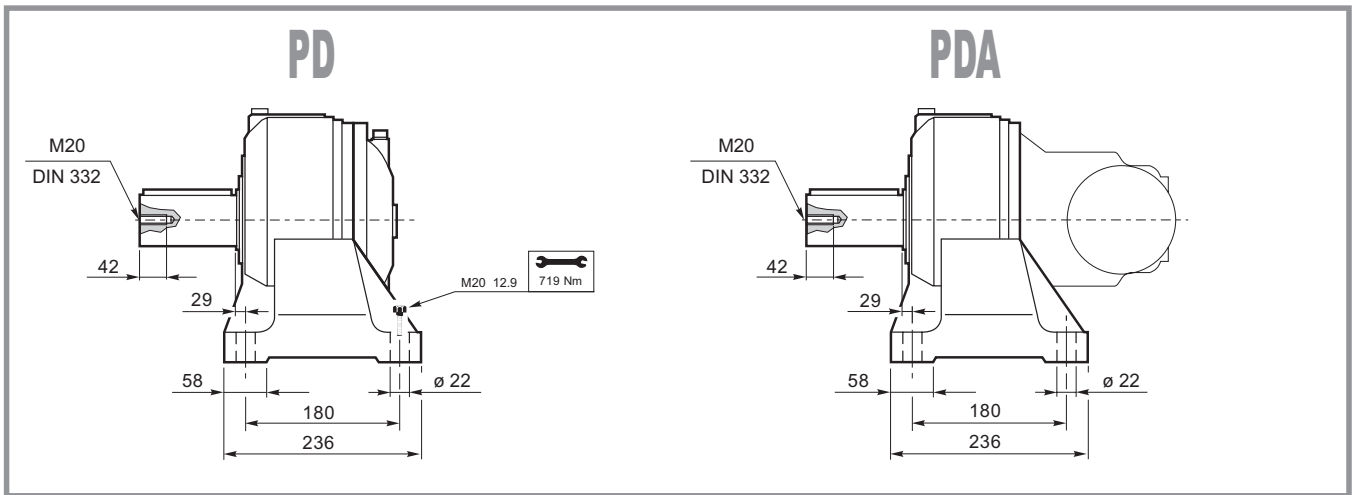



# 020

## S45CR1-S46C1

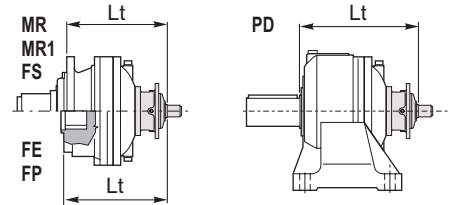
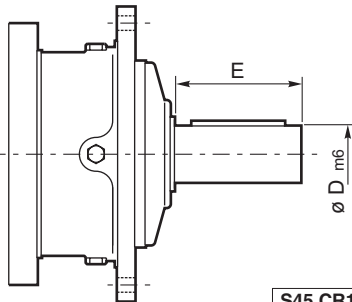

	D m6	E		Lt			
				MR-MR1-FS	FE	FP	PD
<b>S45 CR1</b>	65	105	<b>EM 1020</b>	255	211	185	401
<b>S46 C1</b>	65	105	<b>EM 1020</b>	296	252	226	352

## SU2

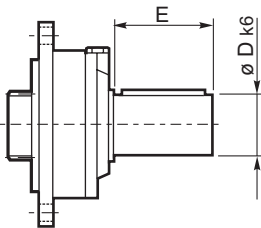

	D k6	E		Lt			
				MR-MR1-FS	FE	FP	PD
<b>SU 2</b>	40	58	<b>EM 1020</b>	252	208	182	308
			<b>ED 2020</b>	305	260	235	361
			<b>ET 3020</b>	344	300	274	400
			<b>EQ 4020</b>	384	339	314	440

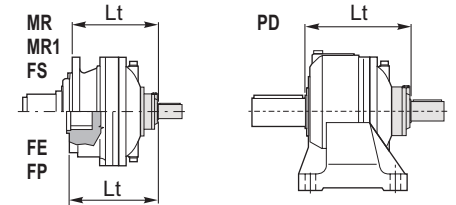

## ⑥ 48.82

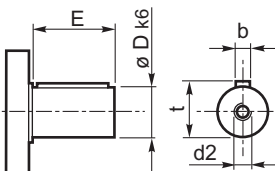

	D	E		Lt
				MR-MR1-FS-FE-FP-PDA
<b>48.82</b>	48	82	<b>EC 2020</b>	280

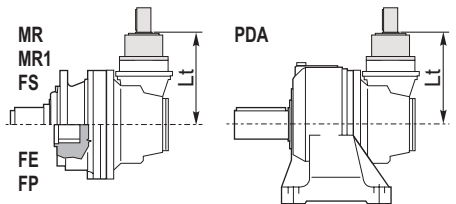

## FL250-FL350-FL450

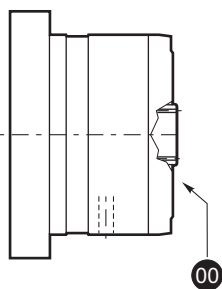

		Lt			
		MR-MR1-FS	FE	FP	PD-PDA
FL250-FL350 FL450	EM 1020	285	241	215	342
	EC 2020	280	280	280	280
	EC 2020*	377	377	377	377

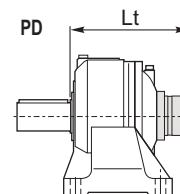
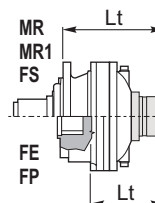

**FL620/10**  
**FL635/10**

**FL620U-FL635U**

SAE A-AA  
Shaft FE

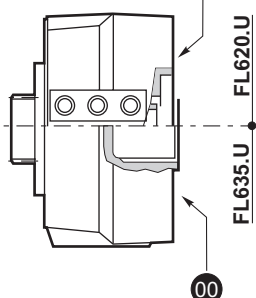

		Lt			
		MR-MR1-FS	FE	FP	PD
FL620/U	EM 1020	296.5	252.5	226.5	352.5
	ED 2020	349.5	304.5	279.5	405.5
	ET 3020	388.5	344.5	318.5	444.5
	EQ 4020	428.5	383.5	358.5	484.5
	EC 2020	324.5	324.5	324.5	324.5
FL635U	EC 2020*	330.5	330.5	330.5	330.5
	EM 1020	283	329	213	339
	ED 2020	336	291	266	392
	ET 3020	375	331	305	431
	EQ 4020	415	370	345	471
FL620/10	EC 2020	311	311	311	311
	EC 2020*	317	317	317	317
	ED 2020	308.5	263.5	—	364
FL635/10	ET 3020	347.5	303.5	—	404
	EQ 4020	387.5	342.5	—	443
FL635/10	ED 2020	290	184	220	346
	ET 3020	329	285	259	385
	EQ 4020	369	325	299	425

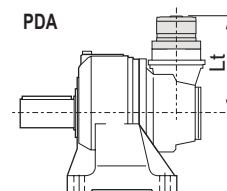
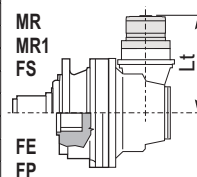

## IEC Motor

		Lt							
		IEC 63	IEC 71	IEC 80 90	IEC 100 112	IEC 132	IEC 160 180	IEC 200	IEC 225
EM 1020	MR-MR1-FS	212	214	219	220	287	328	328	359
EM 1020	FE	168	170	175	176	243	274	284	315
EM 1020	FP								
ED 2020	MR-MR1-FS	265	267	272	273	340			
ED 2020	FE	220	222	227	228	295			
ED 2020	FP								
ET 3020	MR-MR1-FS	304	306	311	312	379			
ET 3020	FE	260	262	267	268	335			
ET 3020	FP								
EQ 4020	MR-MR1-FS	344	346	351	352	419			
EQ 4020	FE	299	301	306	307	374			
EQ 4020	FP								
PD 1020	PD	268	270	275	276	343	374	384	415
PD 2020	PD	321	323	328	379	396	427		
PD 3020	PD	360	362	367	373	435			
PD 4020	PD	400	402	407	408	475			
EC 2020	MR-MR1-FE-FS-FP-PDA	240	242	247	248	315			
EC 2020*	MR-MR1-FE-FS-FP-PDA	246	248	253	254	321			
EC 3020	MR-MR1-FE-FS-FP-PDA	151	151	151	151	238			
EC 4020	MR-MR1-FE-FS-FP-PDA	151	151	151	151	238			

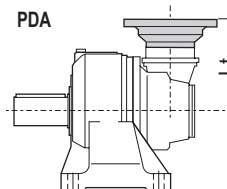
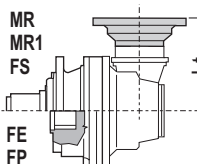
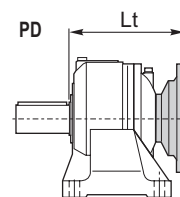
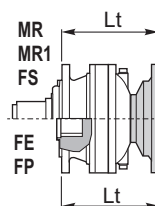

\* (bg) 48





**Flangia ruota**  
Driving flange  
Radnabenflansch  
Flasque de roue  
Brida de la rueda  
Flange de roda

**FA 020**

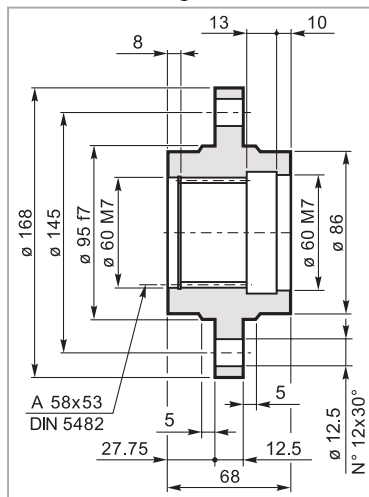

Mat. C40 UNI EN 10083  
Code: 34700641800



**Flangia ruota**  
Driving flange  
Radnabenflansch  
Flasque de roue  
Brida de la rueda  
Flange de roda

**FR 020**

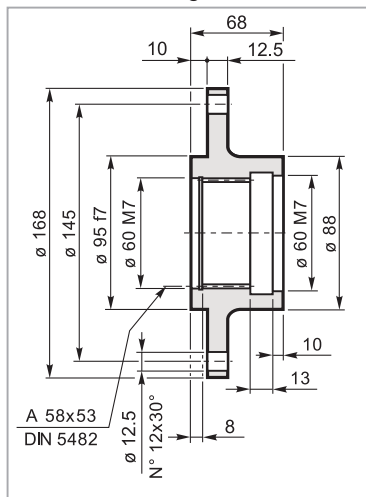

Mat. C40 UNI EN 10083  
Code: 34700131800



**Pignoni**  
Pinion  
Ritzel  
Pignon  
Piñones  
Pinhões

**IR 020**

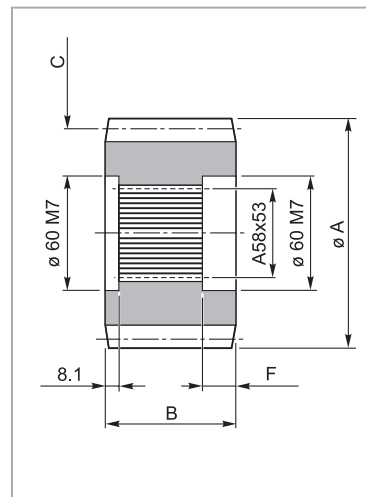

**Manicotto scanalato**  
Splined bush  
Keilmuffe  
Manchon cannelée  
Manguito acanalado  
Luva ranhurada

**MS 020**

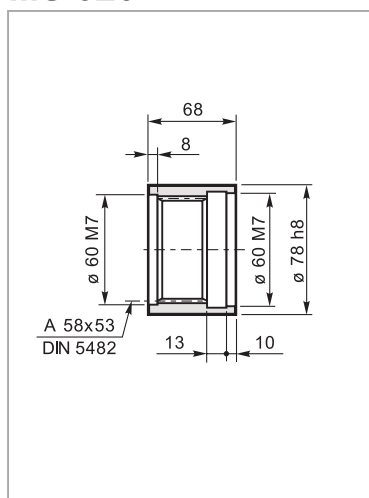

Mat. 39NiCrMo3 UNI EN 10083  
Code: 39102840600



**Rondella di fermo**  
Shaft cover  
Gegenseibe  
Rondelle frein  
Arandela de bloqueo  
Amuela de encosto

**RDF 020**

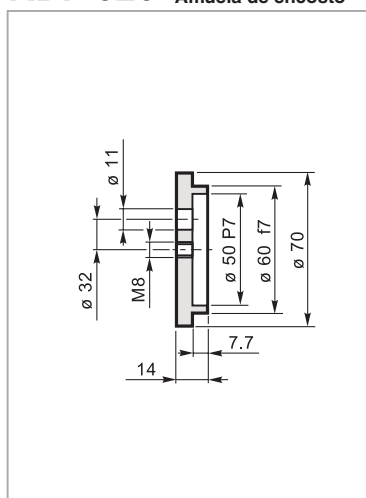

Mat. C40 UNI EN 10083  
Code: 37201040800

code	A	B	C	F
335.0143.0800	114.8	68	M=8 Z=12 X=0.3	23.5
335.0174.0800	99.6	68	M=6 Z=14 X=0.3	24
335.0184.0800	114.8	80	M=8 Z=12 X=0.3	24
335.0274.0800	143	80	M=10 Z=12 X=0.35	23.5
335.0324.0800	136.2	80	M=8 Z=15	23.5
335.0344.0800	152	80	M=10 Z=13 X=0.3	23.5
335.0353.000K	127.6	68	M=8 Z=13 X=0.54	23.5
335.2133.0600	143.4	80	M=8 Z=15 X=0.4	23.5
335.3473.0600	156	80	M=6 Z=24	23
335.4273.0600	142	80	M=8 Z=16	23.5
335.5193.060	115	68	M=5 Z=21	24
335.5942.000	136	80	M=8 Z=14 X=0.4	23.5
335.6273.000	120	68	M=8 Z=13	24



**Barra scanalata**  
Splined bar  
Zugspindel  
Barre cannelée  
Barra acanalada  
Barra ranhurada

**BS 020**

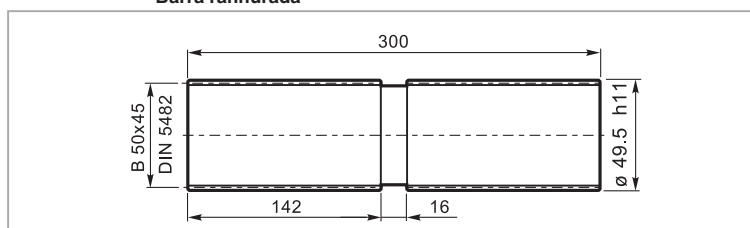

Mat. 39NiCrMo3 UNI EN 10083  
Code: 39126930100

Carichi radiali sugli alberi uscita / Radial loads on output shafts  
 Radiallasten auf de Abtriebswellen / Charges radiales sur les arbres de sortie  
 Cargas sobre los ejes de salida / Cargas radiais nos eixos de saída

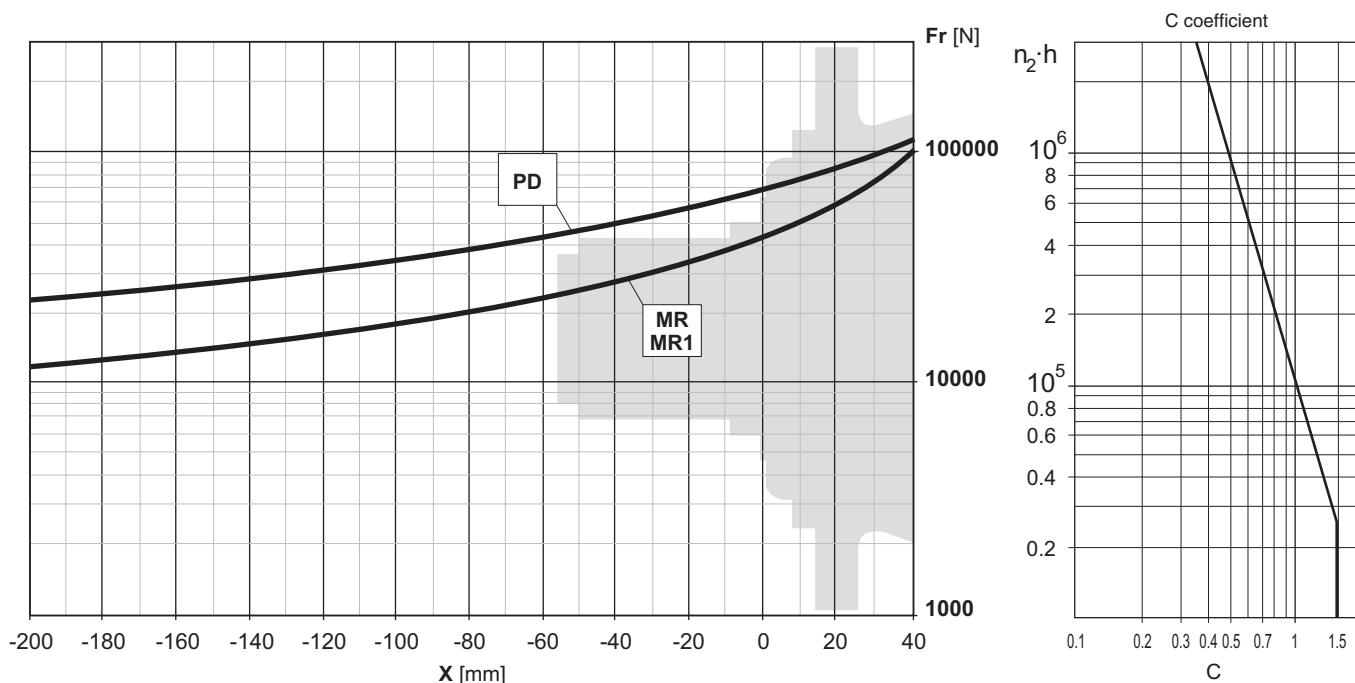

Carichi assiali / Axial loads / Axialkräfte / Charges axiales / Cargas axiales / Forças axiais

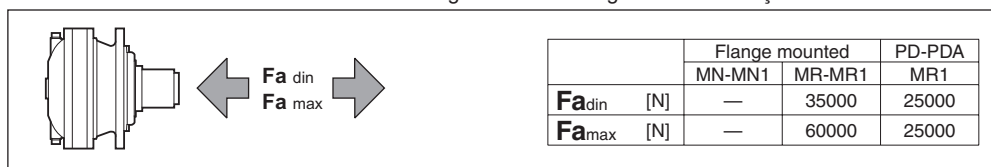

Carichi radiali sugli alberi entrata / Radial loads on input shafts  
 Radiallasten auf de Antriebswellen / Charges radiales sur les arbres d'entrée  
 Cargas sobre los ejes de entrada / Cargas radiais nos eixos de entrada

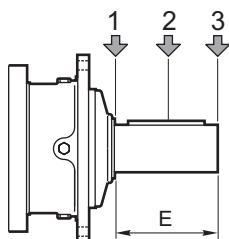

Type	E	$Fr$ [N]					
		$n_1 \cdot h = 10^7$			$n_1 \cdot h = 10^8$		
		1	2	3	1	2	3
S45 CR1	105	10000	6000	4000	5000	3000	2000
S46 C1	105	14000	8800	6400	7000	4400	3200

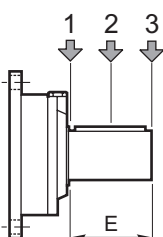

Type	E	$Fr$ [N]					
		$n_1 \cdot h = 10^7$			$n_1 \cdot h = 10^8$		
		1	2	3	1	2	3
SU2	58	3000	2000	1500	1400	1000	700

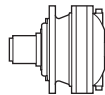

$i_{\text{eff}}$	1500			1000			500			$T_{2\text{max}}$ [Nm]	$P_T$ [kW]	
	$n_2$ [rpm]	$T_2$ [Nm]	$P_2$ [kW]	$n_2$ [rpm]	$T_2$ [Nm]	$P_2$ [kW]	$n_2$ [rpm]	$T_2$ [Nm]	$P_2$ [kW]			
<b>ED 2030</b>												
15.37	98	1510	15.4	65	1705	11.6	32.5	2100	7.2	5600	12	
17.47	86	2121	19.1	57	2395	14.4	28.6	2732	8.2	6000		
20.28	74	2206	17.1	49.3	2314	12.0	24.7	2494	6.4	6000		
22.70	66	2231	15.4	44.1	2519	11.6	22.0	2805	6.5	6000		
26.34	57	2276	13.6	38.0	2383	9.5	19.0	2560	5.1	6000		
31.02	48.4	2134	10.8	32.2	2342	7.9	16.1	2639	4.5	6000		
36.00	41.7	2358	10.3	27.8	2463	7.2	13.9	2640	3.8	6000		
41.64	36.0	2325	8.8	24.0	2446	6.2	12.0	2678	3.4	6000		
43.50	34.5	2027	7.3	23.0	2119	5.1	11.5	2276	2.7	6000		
50.32	29.8	2060	6.4	19.9	2152	4.5	9.9	2309	2.4	6000		
<b>ET 3030</b>												
59.06	25.4	2765	7.4	16.9	2879	5.1	8.5	3076	2.7	6000		8
61.28	24.5	2640	6.8	16.3	2982	5.1	8.2	3671	3.1	6000		
70.98	21.1	2457	5.4	14.1	2775	4.1	7.0	3206	2.4	6000		
83.76	17.9	2900	5.4	11.9	3275	4.1	6.0	3783	2.4	6000		
89.03	16.8	2591	4.6	11.2	2695	3.2	5.6	2876	1.7	6000		
96.88	15.5	3029	4.9	10.3	3421	3.7	5.2	3803	2.1	6000		
108.8	13.8	3051	4.4	9.2	3320	3.2	4.6	3410	1.6	6000		
124.2	12.1	2447	3.1	8.1	2528	2.1	4.0	2658	1.1	6000		
146.6	10.2	2888	3.1	6.8	2983	2.1	3.4	3137	1.1	6000		
157.5	9.5	3042	3.0	6.3	3179	2.1	3.2	3695	1.2	6000		
186.1	8.1	2901	2.4	5.4	3046	1.7	2.7	3292	0.93	6000		
198.9	7.5	2115	1.7	5.0	2221	1.2	2.5	2401	0.63	6000		
215.3	7.0	2953	2.2	4.6	3098	1.5	2.3	3343	0.81	6000		
249.0	6.0	2648	1.7	4.0	2780	1.2	2.0	3006	0.63	6000		
289.0	5.2	2924	1.6	3.5	3197	1.2	1.7	3489	0.63	6000		
325.7	4.6	3101	1.5	3.1	3244	1.0	1.5	3492	0.56	6000		
<b>EQ 4030</b>												
367.7	4.1	3835	1.6	2.7	3888	1.1	1.4	3972	0.57	6000	4	
404.7	3.7	2928	1.1	2.5	2966	0.77	1.2	3029	0.39	6000		
460.3	3.3	3674	1.3	2.2	4000	0.91	1.1	4605	0.52	6000		
495.4	3.0	3874	1.2	2.0	3925	0.83	1.0	4008	0.42	6000		
581.3	2.6	3894	1.1	1.7	3944	0.71	0.86	4027	0.36	6000		
643.5	2.3	3907	0.95	1.6	3956	0.64	0.78	4039	0.33	6000		
691.5	2.2	4002	0.91	1.4	4348	0.66	0.72	4494	0.34	6000		
817.1	1.8	4142	0.80	1.2	4424	0.57	0.61	4516	0.29	6000		
879.4	1.7	3945	0.71	1.1	3994	0.48	0.57	4075	0.24	6000		
1017	1.5	3963	0.61	0.98	4011	0.41	0.49	4092	0.21	6000		
1142	1.3	3550	0.49	0.88	3593	0.33	0.44	3666	0.17	6000		
1304	1.2	2886	0.35	0.77	2961	0.24	0.38	3092	0.12	6000		
1430	1.0	4445	0.49	0.70	4498	0.33	0.35	4589	0.17	6000		
1539	0.97	3406	0.35	0.65	3494	0.24	0.32	3649	0.12	6000		
1806	0.83	3248	0.28	0.55	3304	0.19	0.28	3607	0.11	6000		
1999	0.75	3610	0.28	0.50	3652	0.19	0.25	3969	0.10	6000		
2268	0.66	4502	0.31	0.44	4781	0.22	0.22	5124	0.12	6000		
2502	0.60	4519	0.28	0.40	4572	0.19	0.20	4969	0.10	6000		
2904	0.52	4726	0.26	0.34	5112	0.18	0.17	5767	0.10	6000		
3170	0.47	4042	0.20	0.32	4382	0.15	0.16	5013	0.08	6000		

**1500**  
HOURS LIFE

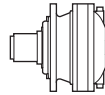

**030**

$i_{eff}$	1500			1000			500			$T_{2max}$ [Nm]	$P_T$ [kW]	
	$n_2$ [rpm]	$T_2$ [Nm]	$P_2$ [kW]	$n_2$ [rpm]	$T_2$ [Nm]	$P_2$ [kW]	$n_2$ [rpm]	$T_2$ [Nm]	$P_2$ [kW]			
<b>ED 2030</b>												
15.37	98	2477	25.3	65	2626	17.9	32.5	2800	9.5	5600	12	
17.47	86	2896	26.0	57	3031	18.2	28.6	3443	10.3	6000		
20.28	74	2654	20.6	49.3	2774	14.3	24.7	3136	8.1	6000		
22.70	66	2984	20.7	44.1	3119	14.4	22.0	3648	8.4	6000		
26.34	57	2732	16.3	38.0	2850	11.3	19.0	3323	6.6	6000		
31.02	48.4	2703	13.7	32.2	2925	9.9	16.1	3250	5.5	6000		
36.00	41.7	2823	12.3	27.8	3053	8.9	13.9	3555	5.2	6000		
41.64	36.0	2857	10.8	24.0	3077	7.7	12.0	3406	4.3	6000		
43.50	34.5	2444	8.8	23.0	2636	6.3	11.5	3082	3.7	6000		
50.32	29.8	2480	7.7	19.9	2726	5.7	9.9	3181	3.3	6000		
<b>ET 3030</b>												
59.06	25.4	3536	9.4	16.9	3860	6.8	8.5	4457	4.0	6000		8
61.28	24.5	3729	9.6	16.3	3821	6.5	8.2	3945	3.4	6000		
70.98	21.1	3221	7.1	14.1	3289	4.9	7.0	3383	2.5	6000		
83.76	17.9	3801	7.1	11.9	3881	4.9	6.0	3993	2.5	6000		
89.03	16.8	3410	6.0	11.2	3718	4.4	5.6	4287	2.5	6000		
96.88	15.5	3831	6.2	10.3	3906	4.2	5.2	4014	2.2	6000		
108.8	13.8	3442	5.0	9.2	3505	3.4	4.6	3599	1.7	6000		
124.2	12.1	2749	3.5	8.1	2840	2.4	4.0	2986	1.3	6000		
146.6	10.2	3244	3.5	6.8	3351	2.4	3.4	3524	1.3	6000		
157.5	9.5	4339	4.3	6.3	4414	2.9	3.2	4527	1.5	6000		
186.1	8.1	3538	3.0	5.4	3856	2.2	2.7	4134	1.2	6000		
198.9	7.5	2594	2.0	5.0	2878	1.5	2.5	3300	0.87	6000		
215.3	7.0	3611	2.6	4.6	3996	1.9	2.3	4195	1.0	6000		
249.0	6.0	3248	2.0	4.0	3603	1.5	2.0	4131	0.87	6000		
289.0	5.2	3769	2.0	3.5	4181	1.5	1.7	4794	0.87	6000		
325.7	4.6	4004	1.9	3.1	4117	1.3	1.5	4480	0.72	6000		
<b>EQ 4030</b>												
367.7	4.1	4047	1.7	2.7	4101	1.2	1.4	4461	0.64	6000	4	
404.7	3.7	3089	1.2	2.5	3238	0.84	1.2	3612	0.47	6000		
460.3	3.3	5066	1.7	2.2	5133	1.2	1.1	5584	0.64	6000		
495.4	3.0	4087	1.3	2.0	4188	0.89	1.0	4674	0.49	6000		
581.3	2.6	4107	1.1	1.7	4297	0.77	0.86	4791	0.43	6000		
643.5	2.3	4121	1.0	1.6	4367	0.71	0.78	4867	0.40	6000		
691.5	2.2	4585	1.0	1.4	4895	0.74	0.72	5458	0.41	6000		
817.1	1.8	4711	0.91	1.2	5027	0.64	0.61	5599	0.36	6000		
879.4	1.7	4303	0.77	1.1	4588	0.55	0.57	5105	0.30	6000		
1017	1.5	4404	0.68	0.98	4693	0.48	0.49	5218	0.27	6000		
1142	1.3	4114	0.57	0.88	4382	0.40	0.44	4869	0.22	6000		
1304	1.2	3349	0.40	0.77	3564	0.29	0.38	3960	0.16	6000		
1430	1.0	5151	0.57	0.70	5486	0.40	0.35	6095	0.22	6000		
1539	0.97	3952	0.40	0.65	4205	0.29	0.32	4673	0.16	6000		
1806	0.83	4071	0.35	0.55	4327	0.25	0.28	4791	0.14	6000		
1999	0.75	4487	0.35	0.50	4772	0.25	0.25	5290	0.14	6000		
2268	0.66	5786	0.40	0.44	6151	0.28	0.22	6814	0.16	6000		
2502	0.60	5617	0.35	0.40	5974	0.25	0.20	6623	0.14	6000		
2904	0.52	6519	0.35	0.34	6933	0.25	0.17	7612	0.14	6000		
3170	0.47	5827	0.29	0.32	6280	0.21	0.16	7121	0.12	6000		

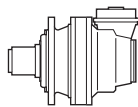

$i_{eff}$	1500			1000			500			$T_{2max}$ [Nm]	$P_T$ [kW]
	$n_2$ [rpm]	$T_2$ [Nm]	$P_2$ [kW]	$n_2$ [rpm]	$T_2$ [Nm]	$P_2$ [kW]	$n_2$ [rpm]	$T_2$ [Nm]	$P_2$ [kW]		

### EC 3030 - PDA 3030

35.49	42.3	1160	5.1	28.2	1310	3.9	14.1	1613	2.4	6000
41.88	35.8	1369	5.1	23.9	1546	3.9	11.9	1903	2.4	6000
46.09	32.5	1507	5.1	21.7	1702	3.9	10.8	2095	2.4	6000
52.42	28.6	1714	5.1	19.1	1935	3.9	9.5	2383	2.4	6000
54.39	27.6	1778	5.1	18.4	2008	3.9	9.2	2472	2.4	6000
60.84	24.7	1989	5.1	16.4	2246	3.9	8.2	2765	2.4	6000
68.09	22.0	2226	5.1	14.7	2514	3.9	7.3	3095	2.4	6000
79.02	19.0	2560	5.1	12.7	2664	3.5	6.3	2845	1.9	6000
88.66	16.9	1774	3.1	11.3	2003	2.4	5.6	2467	1.5	6000
99.17	15.1	1984	3.1	10.1	2241	2.4	5.0	2759	1.5	6000
111.0	13.5	2221	3.1	9.0	2508	2.4	4.5	3088	1.5	6000
128.8	11.6	2577	3.1	7.8	2791	2.3	3.9	3118	1.3	6000
140.2	10.7	2023	2.3	7.1	2130	1.6	3.6	2310	0.86	6000
151.7	9.9	2826	2.9	6.6	2973	2.1	3.3	3219	1.1	6000
176.0	8.5	2767	2.5	5.7	2873	1.7	2.8	3336	0.99	6000
203.6	7.4	2805	2.2	4.9	2960	1.5	2.5	3356	0.86	6000
215.8	7.0	2391	1.7	4.6	2486	1.2	2.3	2894	0.70	6000
244.1	6.1	2853	1.8	4.1	3081	1.3	2.0	3576	0.77	6000
282.3	5.3	2908	1.6	3.5	3181	1.2	1.8	3480	0.65	6000

5

### EC 4030 - PDA 4030

319.9	4.7	3817	1.9	3.1	3870	1.3	1.6	3956	0.65	6000
347.1	4.3	3262	1.5	2.9	3306	1.0	1.4	3377	0.51	6000
401.5	3.7	3278	1.3	2.5	3321	0.87	1.2	3392	0.44	6000
473.7	3.2	3868	1.3	2.1	3919	0.87	1.1	4002	0.44	6000
481.2	3.1	3298	1.1	2.1	3340	0.73	1.0	3410	0.37	6000
567.9	2.6	3891	1.1	1.8	3941	0.73	0.88	4024	0.37	6000
656.8	2.3	3909	0.94	1.5	3959	0.63	0.76	4041	0.32	6000
716.7	2.1	3242	0.71	1.4	3329	0.49	0.70	3479	0.25	6000
822.2	1.8	4147	0.79	1.2	4502	0.57	0.61	5059	0.32	6000
930.9	1.6	3528	0.60	1.1	3572	0.40	0.54	3645	0.21	6000
993.8	1.5	3312	0.52	1.0	3399	0.36	0.50	3551	0.19	6000
1165	1.3	4417	0.60	0.86	4471	0.40	0.43	4563	0.21	6000
1291	1.2	3563	0.43	0.77	3606	0.29	0.39	3704	0.15	6000
1352	1.1	4059	0.47	0.74	4403	0.34	0.37	5043	0.20	6000
1616	0.93	4461	0.43	0.62	4514	0.29	0.31	4637	0.15	6000
1848	0.81	4322	0.37	0.54	4683	0.27	0.27	4963	0.14	6000
1959	0.77	3815	0.31	0.51	4218	0.23	0.26	4817	0.13	6000
2208	0.68	4043	0.29	0.45	4134	0.20	0.23	4500	0.11	6000
2563	0.59	4611	0.28	0.39	4798	0.20	0.20	5222	0.11	6000
2964	0.51	4227	0.22	0.34	4616	0.16	0.17	5138	0.09	6000
3097	0.48	4023	0.20	0.32	4362	0.15	0.16	4991	0.08	6000

3

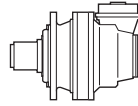

i <sub>eff</sub>	1500			1000			500			T <sub>2max</sub> [Nm]	P <sub>T</sub> [kW]
	n <sub>2</sub> [rpm]	T <sub>2</sub> [Nm]	P <sub>2</sub> [kW]	n <sub>2</sub> [rpm]	T <sub>2</sub> [Nm]	P <sub>2</sub> [kW]	n <sub>2</sub> [rpm]	T <sub>2</sub> [Nm]	P <sub>2</sub> [kW]		

**EC 3030 - PDA 3030**

35.49	42.3	2050	9.1	28.2	2315	6.8	14.1	2850	4.2	6000
41.88	35.8	2419	9.1	23.9	2731	6.8	11.9	3363	4.2	6000
46.09	32.5	2662	9.1	21.7	2873	6.5	10.8	2971	3.4	6000
52.42	28.6	3028	9.1	19.1	3419	6.8	9.5	4210	4.2	6000
54.39	27.6	3141	9.1	18.4	3390	6.5	9.2	3505	3.4	6000
60.84	24.7	3136	8.1	16.4	3429	5.9	8.2	3967	3.4	6000
68.09	22.0	3648	8.4	14.7	3978	6.1	7.3	4388	3.4	6000
79.02	19.0	3323	6.6	12.7	3626	4.8	6.3	4185	2.8	6000
88.66	16.9	3134	5.6	11.3	3474	4.1	5.6	3573	2.1	6000
99.17	15.1	3491	5.5	10.1	3803	4.0	5.0	4380	2.3	6000
111.0	13.5	3924	5.6	9.0	4350	4.1	4.5	4472	2.1	6000
128.8	11.6	3690	4.5	7.8	4014	3.3	3.9	4614	1.9	6000
140.2	10.7	2491	2.8	7.1	2632	2.0	3.6	3129	1.2	6000
151.7	9.9	3455	3.6	6.6	3662	2.5	3.3	4107	1.4	6000
176.0	8.5	3938	3.5	5.7	4251	2.5	2.8	4767	1.4	6000
203.6	7.4	3619	2.8	4.9	3824	2.0	2.5	4546	1.2	6000
215.8	7.0	3433	2.5	4.6	3736	1.8	2.3	4298	1.0	6000
244.1	6.1	4166	2.7	4.1	4565	2.0	2.0	4851	1.0	6000
282.3	5.3	3759	2.1	3.5	4157	1.5	1.8	4777	0.89	6000

5

**EC 4030 - PDA 4030**

319.9	4.7	4027	2.0	3.1	4082	1.3	1.6	4363	0.71	6000
347.1	4.3	3442	1.6	2.9	3487	1.1	1.4	3845	0.58	6000
401.5	3.7	3458	1.4	2.5	3524	0.92	1.2	3933	0.51	6000
473.7	3.2	4081	1.4	2.1	4158	0.92	1.1	4641	0.51	6000
481.2	3.1	3478	1.1	2.1	3628	0.79	1.0	4045	0.44	6000
567.9	2.6	4104	1.1	1.8	4281	0.79	0.88	4774	0.44	6000
656.8	2.3	4123	0.99	1.5	4381	0.70	0.76	4882	0.39	6000
716.7	2.1	3642	0.80	1.4	3740	0.55	0.70	4160	0.30	6000
822.2	1.8	5162	0.99	1.2	5485	0.70	0.61	6112	0.39	6000
930.9	1.6	3984	0.67	1.1	4246	0.48	0.54	4721	0.27	6000
993.8	1.5	3720	0.59	1.0	3933	0.41	0.50	4372	0.23	6000
1165	1.3	4987	0.67	0.86	5315	0.48	0.43	5910	0.27	6000
1291	1.2	4194	0.51	0.77	4465	0.36	0.39	4958	0.20	6000
1352	1.1	5788	0.67	0.74	6168	0.48	0.37	6859	0.27	6000
1616	0.93	5250	0.51	0.62	5590	0.36	0.31	6207	0.20	6000
1848	0.81	5608	0.48	0.54	5965	0.34	0.27	6613	0.19	6000
1959	0.77	5446	0.44	0.51	5792	0.31	0.26	6423	0.17	6000
2208	0.68	5079	0.36	0.45	5397	0.26	0.23	5977	0.14	6000
2563	0.59	5894	0.36	0.39	6264	0.26	0.20	6937	0.14	6000
2964	0.51	5800	0.31	0.34	6163	0.22	0.17	6824	0.12	6000
3097	0.48	5802	0.29	0.32	6253	0.21	0.16	7092	0.12	6000

3

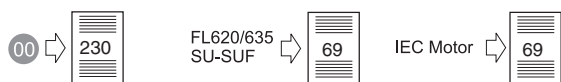
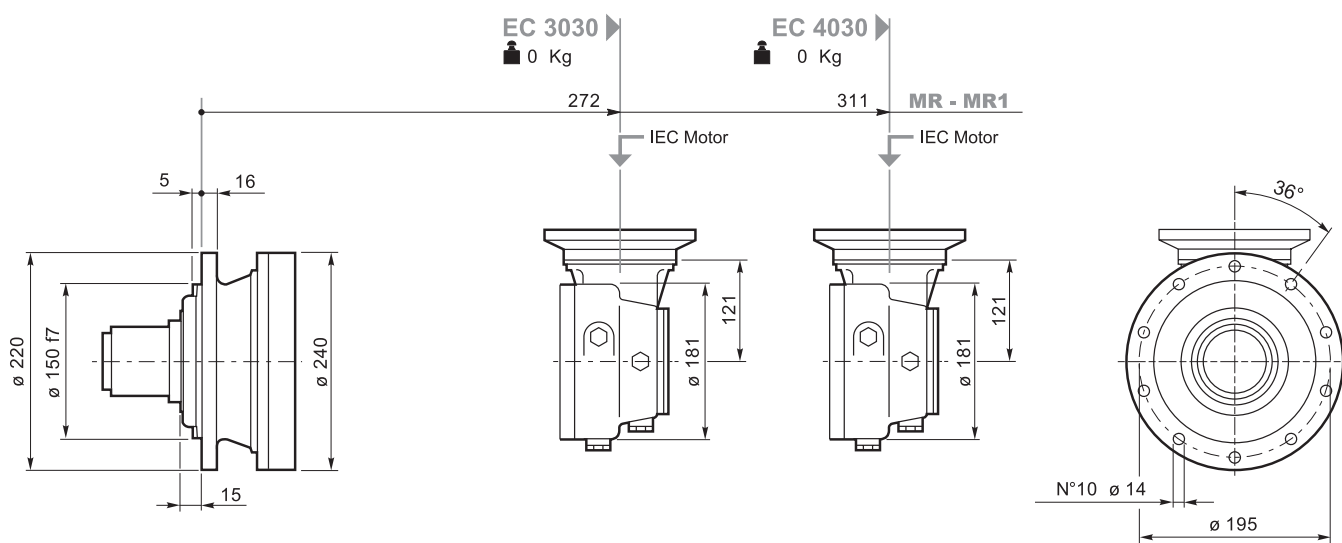
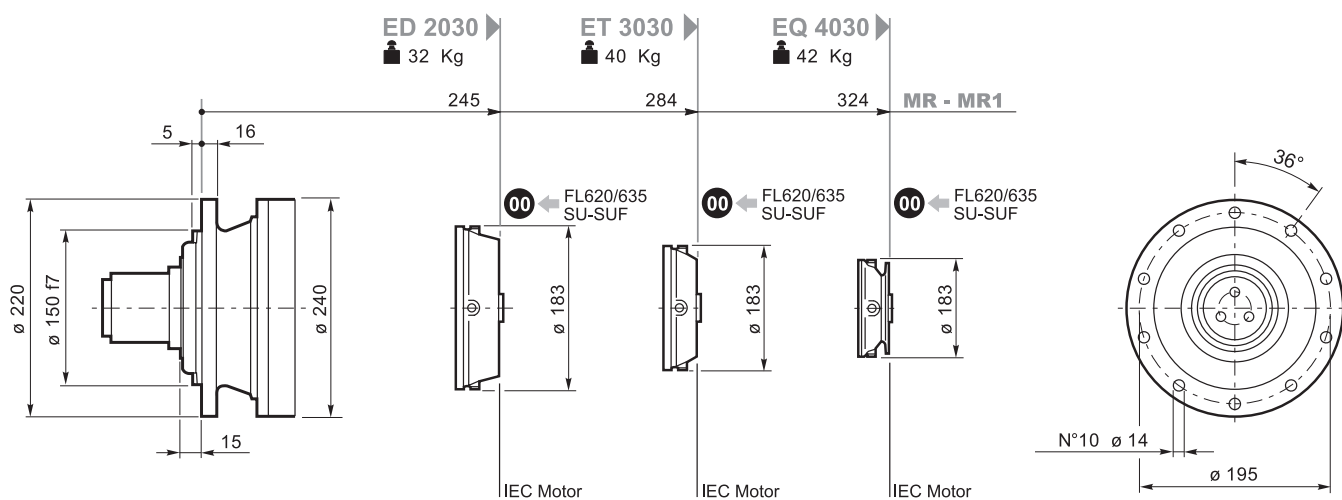
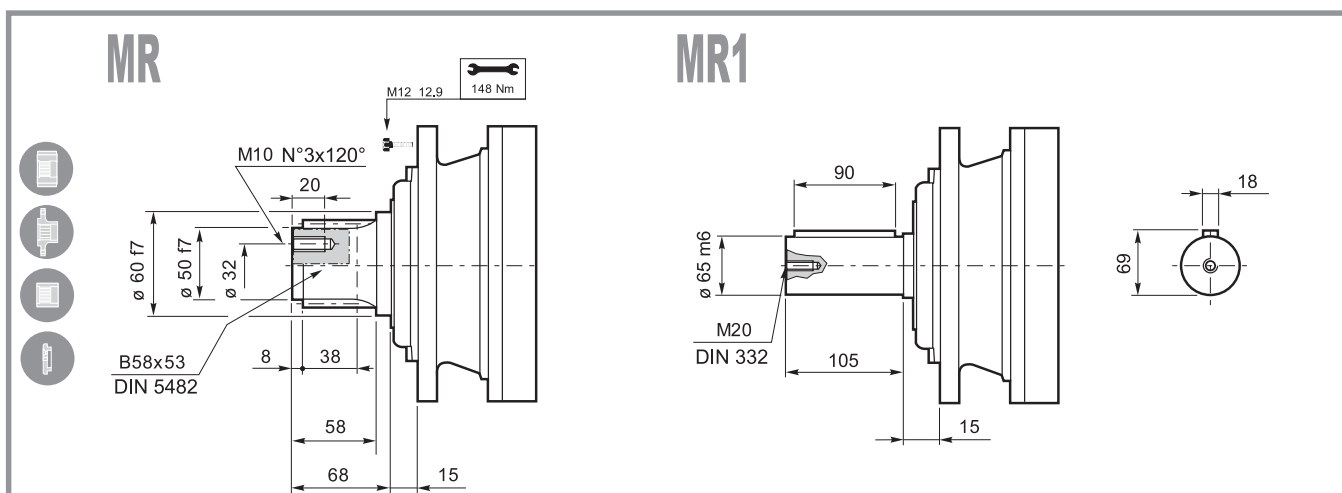

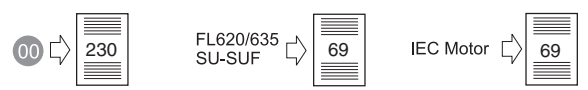
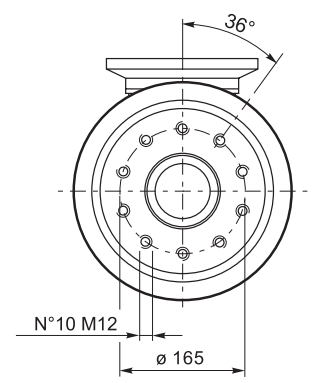
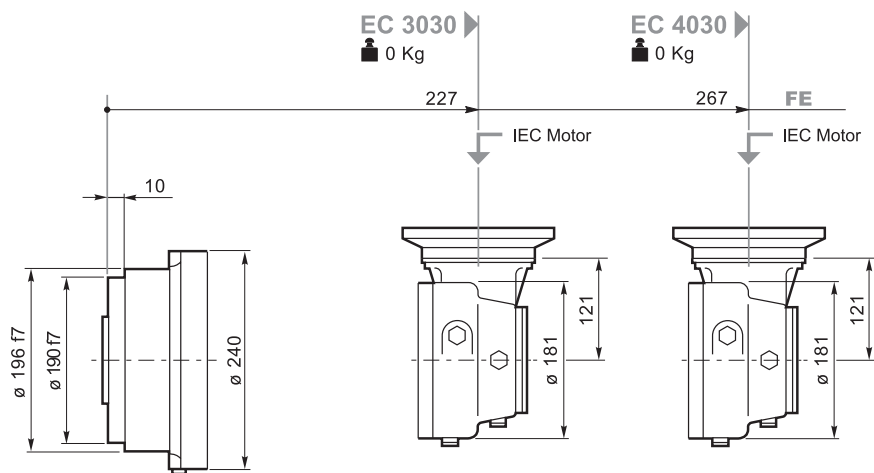
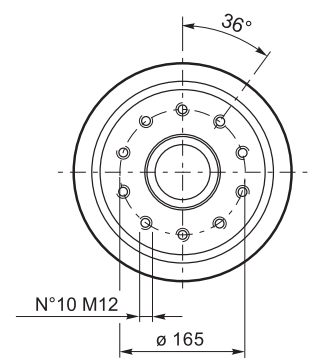
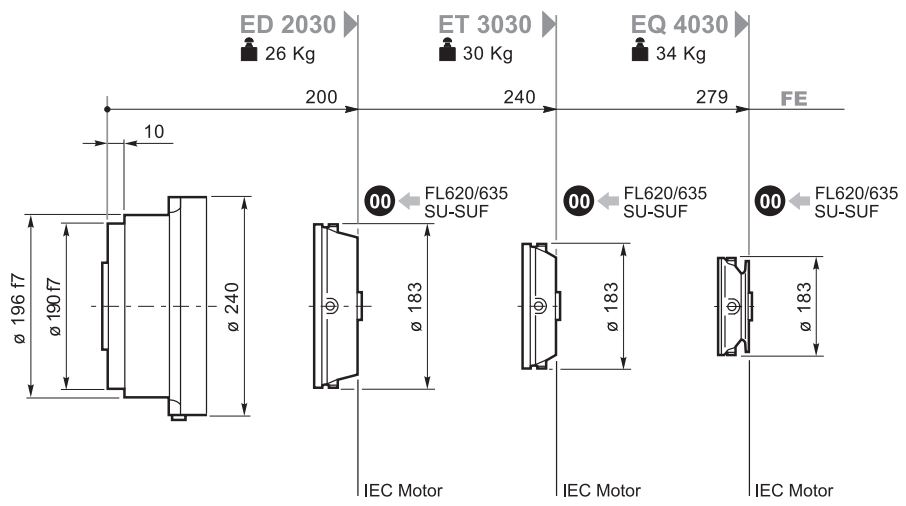
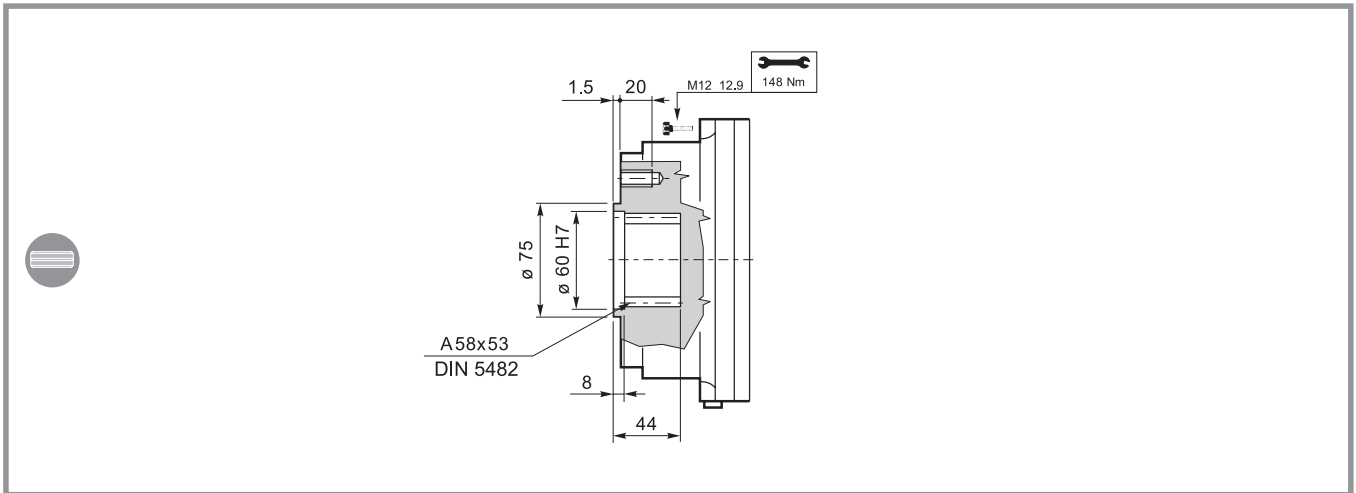



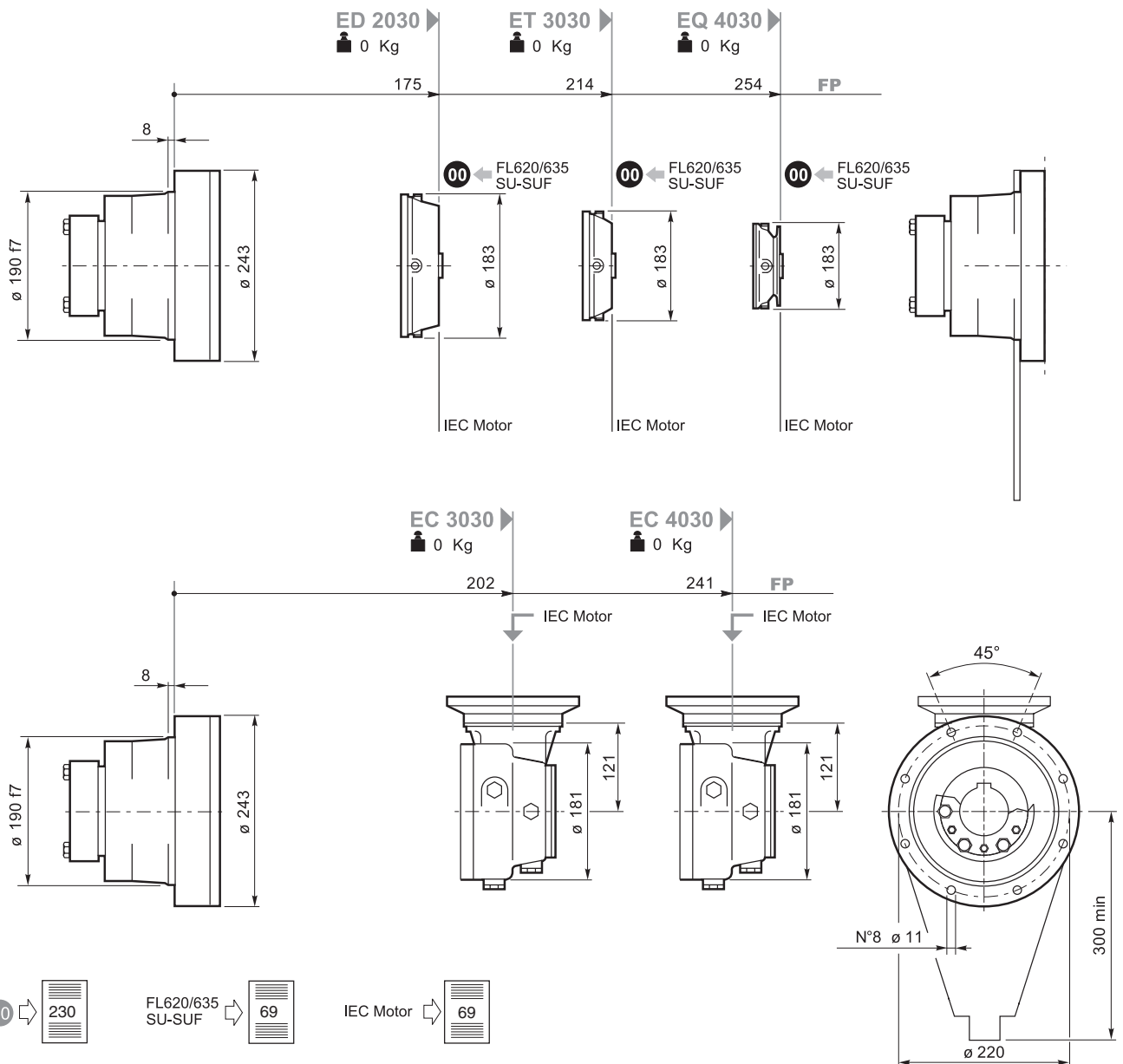
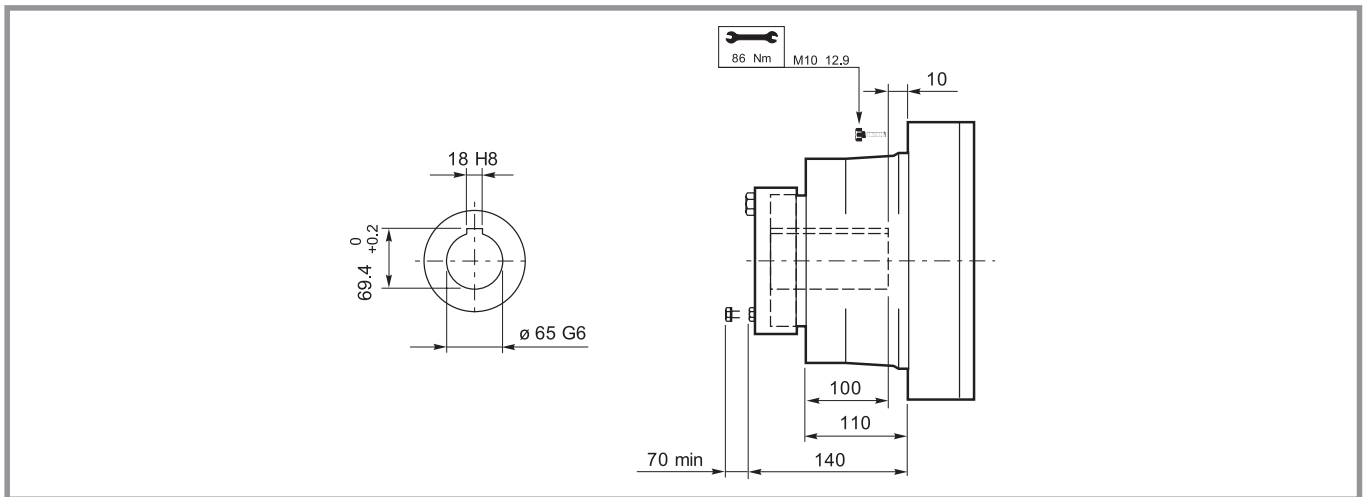

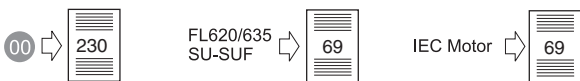
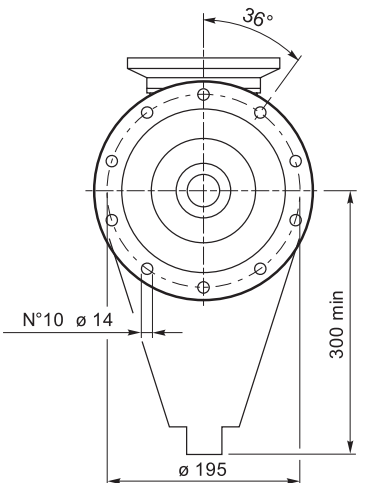
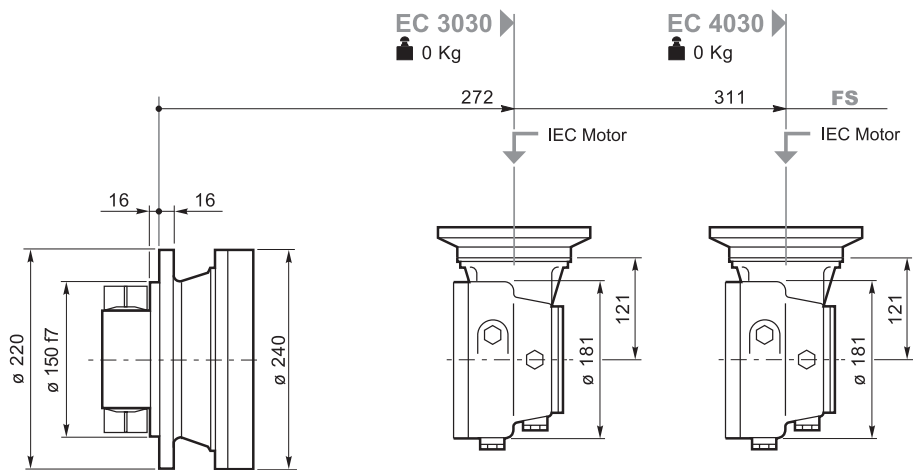
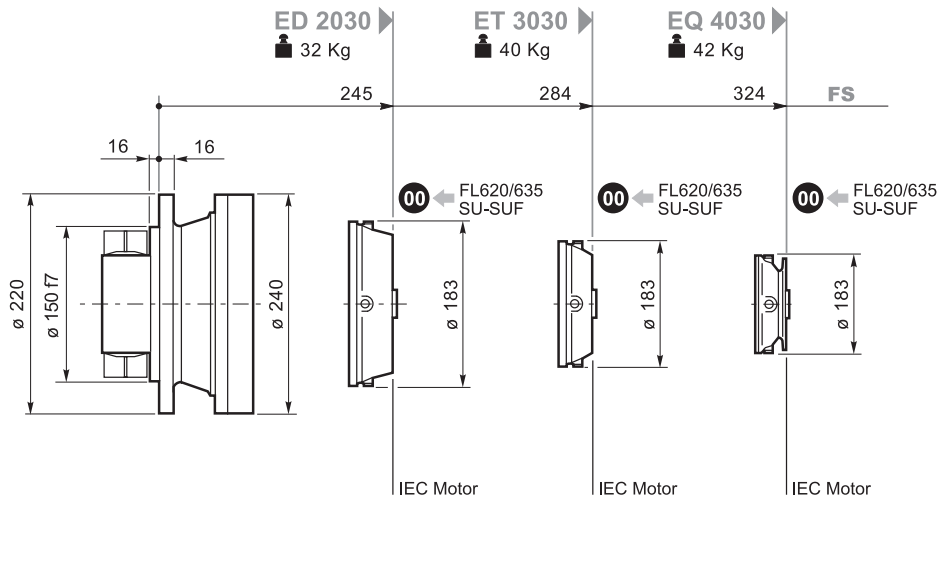
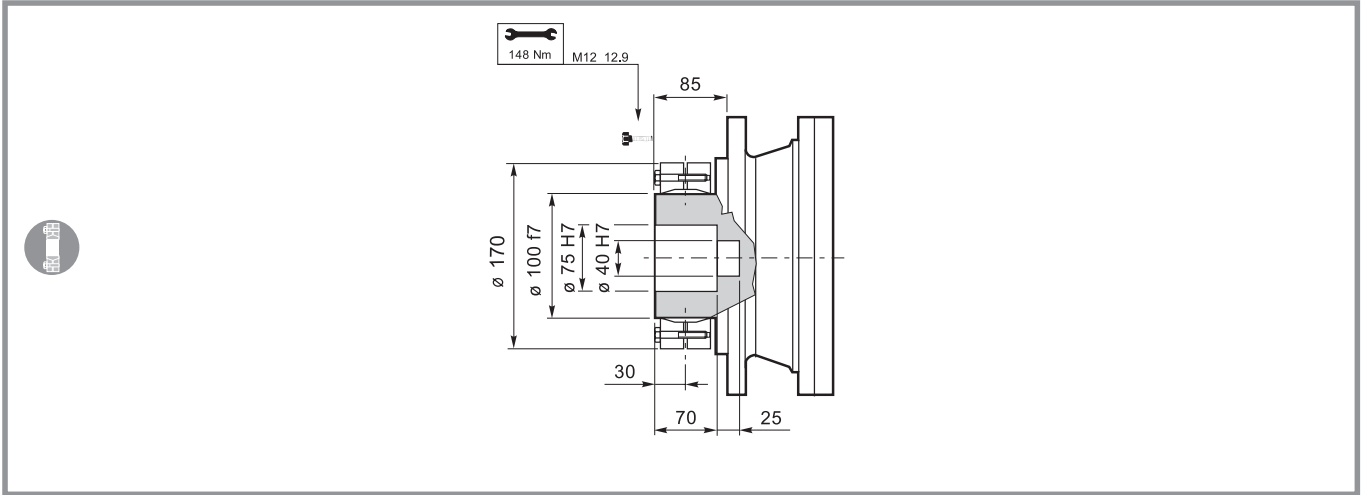

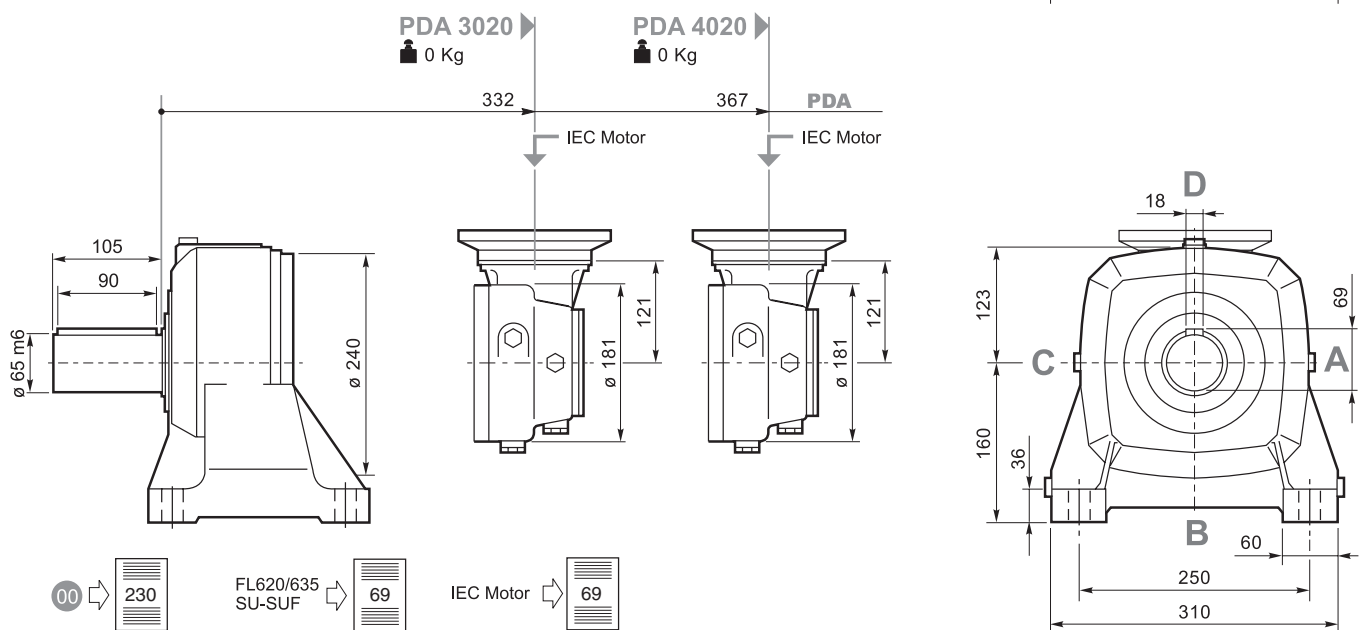
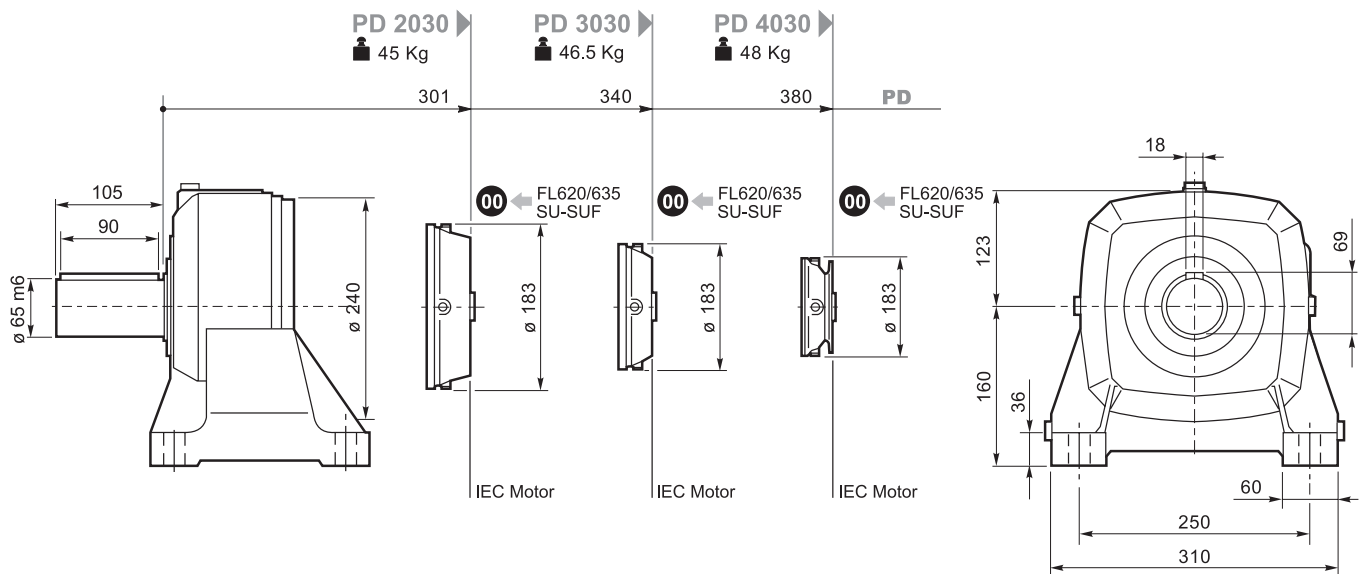
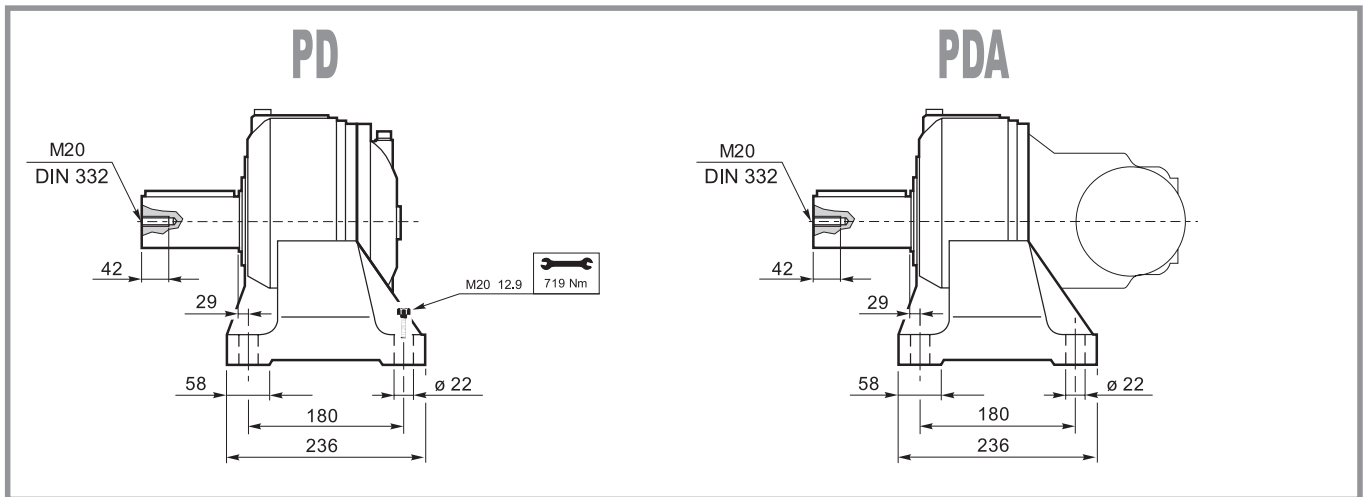

## SU2

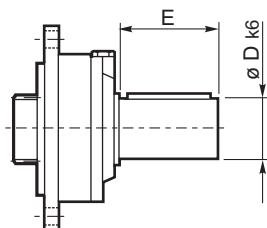

	D k6	E	Lt			
			MR-MR1-FS	FE	PD	
SU 2	40	58	ED 2030	305	260	361
			ET 3030	344	300	400
			EQ 4030	401	339	440

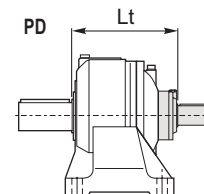
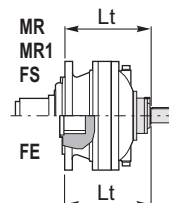

## FL620/10-FL635/10

## FL620U-FL635U

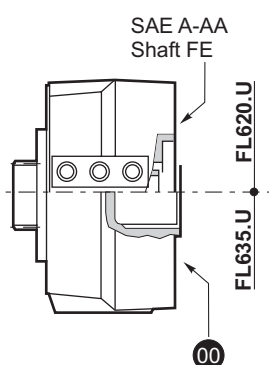

		Lt		
		MR-MR1-FS	FE	PD
FL620/U	ED 2030	349.5	304.5	405.5
	ED 3030	388.5	344.5	444.5
	EQ 4030	428.5	383.5	484.5
FL635U	ED 2030	336	291	392
	ET 3030	375	331	431
	EQ 4030	415	370	471
FL620/10	ED 2030	309	264	470
	ET 3030	348	304	510
	EQ 4030	388	343	550
FL635/10	ED 2030	290	245	451
	ET 3030	329	285	491
	EQ 4030	369	324	531.1

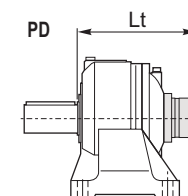
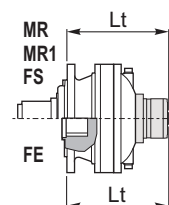

## IEC Motor

		Lt				
		IEC 63	IEC 71	IEC 80 90	IEC 100 112	IEC 132
ED 2030	MR-MR1-FS	265	267	272	273	340
ET 3030	MR-MR1-FS	304	306	311	312	379
EQ 4030	MR-MR1-FS	344	346	351	352	419
ED 2030	FE	220	222	227	228	295
ET 3030	FE	260	262	267	268	335
EQ 4030	FE	299	301	306	307	374
PD 2030	PD	426	428	463	434	395.5
PD 3030	PD	465	467	472	473	540
PD 4030	PD	505	507	512	513	580
EC 3030	MR-MR1-FE-FS-FP-PDA	151	151	151	151	238
EC 4030	MR-MR1-FE-FS-FP-PDA	151	151	151	151	238

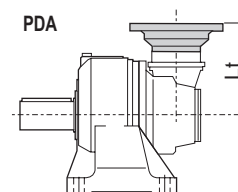
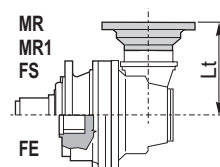
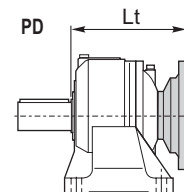
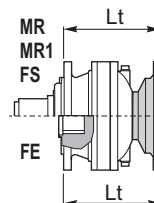



**Flangia ruota**  
Driving flange  
Radnabenflansch  
Flasque de roue  
Brida de la rueda  
Flange de roda

**FA 045**

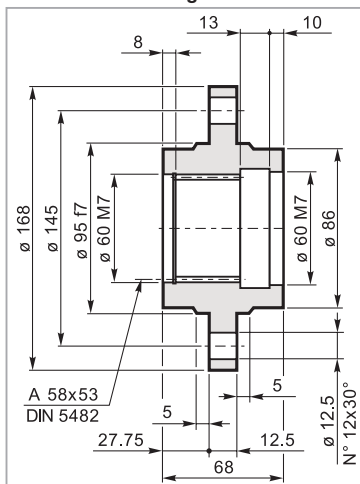

Mat. C40 UNI EN 10083  
Code: 34700641800



**Flangia ruota**  
Driving flange  
Radnabenflansch  
Flasque de roue  
Brida de la rueda  
Flange de roda

**FR 045**

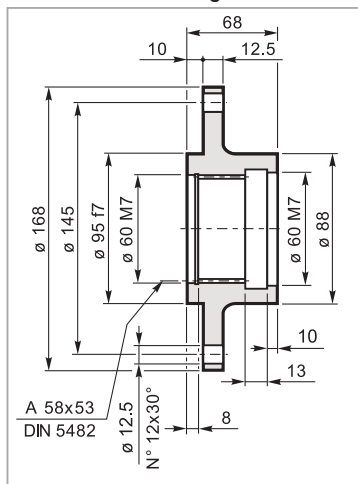

Mat. C40 UNI EN 10083  
Code: 34700131800



**Pignoni**  
Pinion  
Ritzel  
Pignon  
Piñones  
Pinhões

**IR 045**

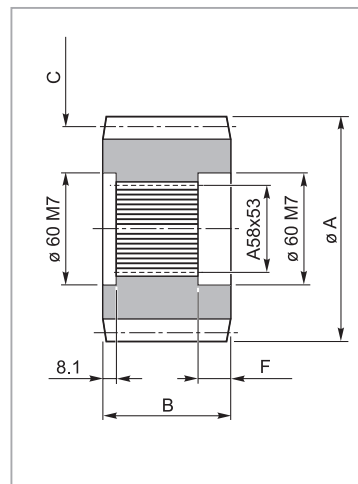

**Manicotto scanalato**  
Splined bush  
Keilmuffe  
Manchon cannelée  
Manguito acanalado  
Luva ranhurada

**MS 045**

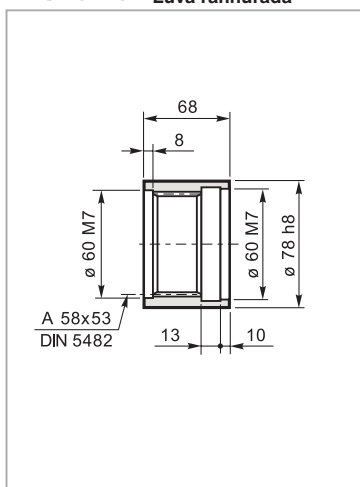

Mat. 39NiCrMo3 UNI EN 10083  
Code: 39102840600



**Rondella di fermo**  
Shaft cover  
Gegenscheibe  
Rondelle frein  
Arandela de bloqueo  
Amuela de encosto

**RDF 045**

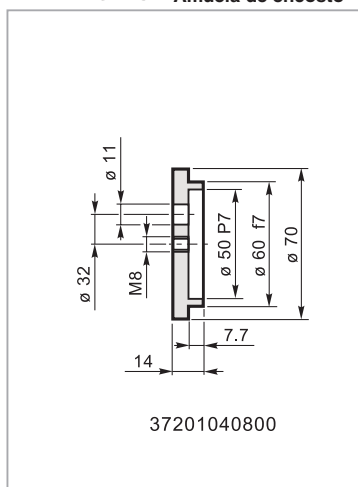

Mat. C40 UNI EN 10083  
Code:

code	A	B	C	F
335.0143.0800	114.8	68	M=8 Z=12 X=0.3	23.5
335.0174.0800	99.6	68	M=6 Z=14 X=0.3	24
335.0184.0800	114.8	80	M=8 Z=12 X=0.3	24
335.0274.0800	143	80	M=10 Z=12 X=0.35	23.5
335.0324.0800	136.2	80	M=8 Z=15	23.5
335.0344.0800	152	80	M=10 Z=13 X=0.3	23.5
335.0353.000K	127.6	68	M=8 Z=13 X=0.54	23.5
335.2133.0600	143.4	80	M=8 Z=15 X=0.4	23.5
335.3473.0600	156	80	M=6 Z=24	23
335.4273.0600	142	80	M=8 Z=16	23.5
335.5193.060	115	68	M=5 Z=21	24
335.5942.000	136	80	M=8 Z=14 X=0.4	23.5
335.6273.000	120	68	M=8 Z=13	24



**Barra scanalata**  
Splined bar  
Zugspindel  
Barre cannelée  
Barra acanalada  
Barra ranhurada

**BS 045**

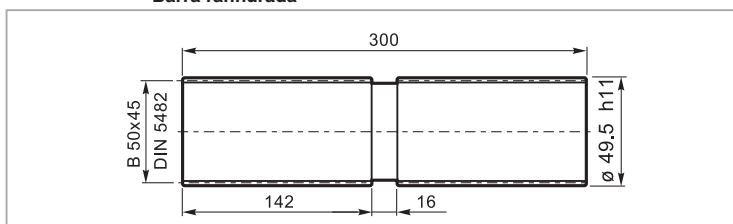

Mat. 39NiCrMo3 UNI EN 10083  
Code: 39126930100

Carichi radiali sugli alberi uscita / Radial loads on output shafts  
 Radiallasten auf de Abtriebswellen / Charges radiales sur les arbres de sortie  
 Cargas sobre los ejes de salida / Cargas radiais nos eixos de saida

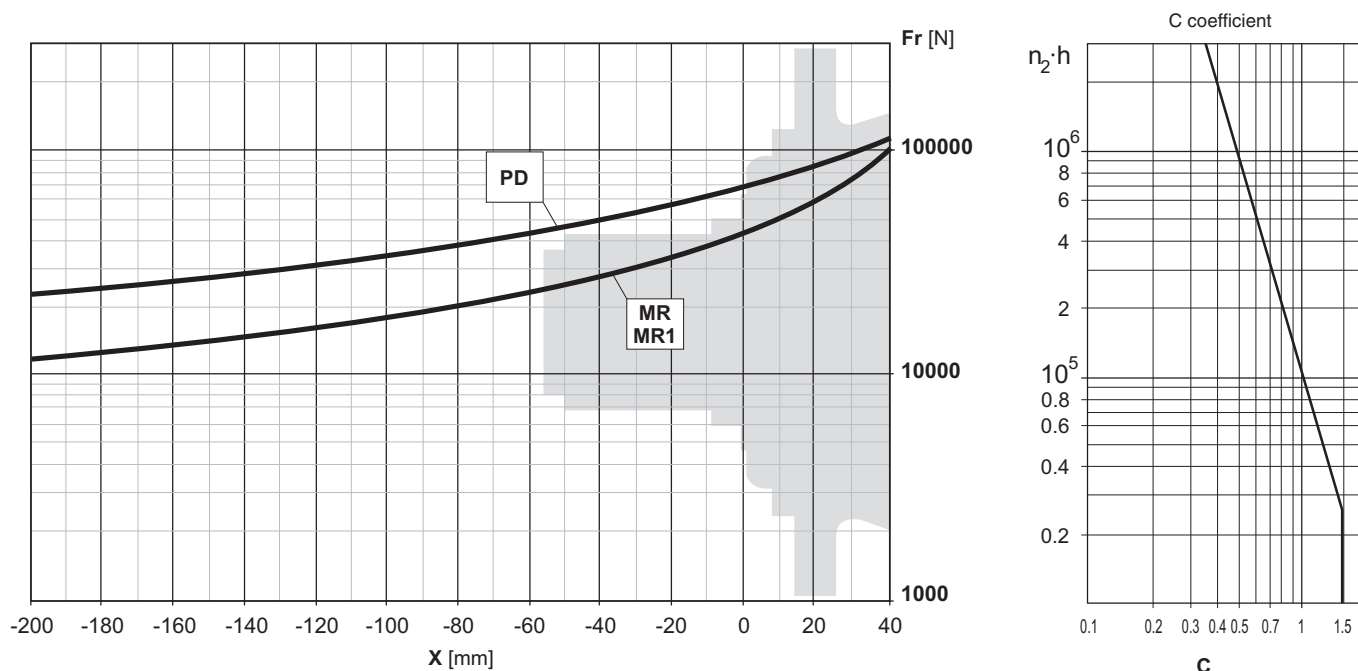

Carichi assiali / Axial loads / Axialkräfte / Charges axiales / Cargas axiales / Forças axiais

		Flange mounted		PD-PDA
		MN-MN1	MR-MR1	MR1
<b>Fa<sub>din</sub></b>	[N]	—	35000	25000
<b>Fa<sub>max</sub></b>	[N]	—	60000	25000

Carichi radiali sugli alberi entrata / Radial loads on input shafts  
 Radiallasten auf de Antriebswellen / Charges radiales sur les arbres d'entrée  
 Cargas sobre los ejes de entrada / Cargas radiais nos eixos de entrada

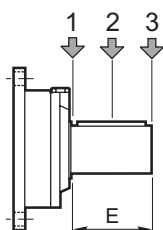

Type	E	Fr [N]					
		$n_1 \cdot h = 10^7$			$n_1 \cdot h = 10^8$		
		1	2	3	1	2	3
<b>SU2</b>	58	3000	2000	1500	1400	1000	700

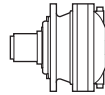

$i_{eff}$	1500			1000			500			$T_{2max}$ [Nm]	$P_T$ [kW]	
	$n_2$ [rpm]	$T_2$ [Nm]	$P_2$ [kW]	$n_2$ [rpm]	$T_2$ [Nm]	$P_2$ [kW]	$n_2$ [rpm]	$T_2$ [Nm]	$P_2$ [kW]			
<b>ED 2040</b>												
15.37	98	1510	15.4	65	1705	11.6	32.5	2100	7.2	5600	12	
17.47	86	2121	19.1	57	2395	14.4	28.6	2732	8.2	6000		
20.28	74	2206	17.1	49.3	2314	12.0	24.7	2494	6.4	6000		
22.70	66	2231	15.4	44.1	2519	11.6	22.0	2805	6.5	6000		
26.34	57	2276	13.6	38.0	2383	9.5	19.0	2560	5.1	6000		
31.02	48.4	2134	10.8	32.2	2342	7.9	16.1	2639	4.5	6000		
36.00	41.7	2358	10.3	27.8	2463	7.2	13.9	2640	3.8	6000		
41.64	36.0	2325	8.8	24.0	2446	6.2	12.0	2678	3.4	6000		
43.50	34.5	2027	7.3	23.0	2119	5.1	11.5	2276	2.7	6000		
50.32	29.8	2060	6.4	19.9	2152	4.5	9.9	2309	2.4	6000		
<b>ET 3040</b>												
59.06	25.4	2765	7.4	16.9	2879	5.1	8.5	3076	2.7	6000		8
61.28	24.5	2640	6.8	16.3	2982	5.1	8.2	3671	3.1	6000		
70.98	21.1	2457	5.4	14.1	2775	4.1	7.0	3206	2.4	6000		
83.76	17.9	2900	5.4	11.9	3275	4.1	6.0	3783	2.4	6000		
89.03	16.8	2591	4.6	11.2	2695	3.2	5.6	2876	1.7	6000		
96.88	15.5	3029	4.9	10.3	3421	3.7	5.2	3803	2.1	6000		
108.8	13.8	3051	4.4	9.2	3320	3.2	4.6	3410	1.6	6000		
124.2	12.1	2447	3.1	8.1	2528	2.1	4.0	2658	1.1	6000		
146.6	10.2	2888	3.1	6.8	2983	2.1	3.4	3137	1.1	6000		
157.5	9.5	3042	3.0	6.3	3179	2.1	3.2	3695	1.2	6000		
186.1	8.1	2901	2.4	5.4	3046	1.7	2.7	3292	0.93	6000		
198.9	7.5	2115	1.7	5.0	2221	1.2	2.5	2401	0.63	6000		
215.3	7.0	2953	2.2	4.6	3098	1.5	2.3	3343	0.81	6000		
249.0	6.0	2648	1.7	4.0	2780	1.2	2.0	3006	0.63	6000		
289.0	5.2	2924	1.6	3.5	3197	1.2	1.7	3489	0.63	6000		
325.7	4.6	3101	1.5	3.1	3244	1.0	1.5	3492	0.56	6000		
<b>EQ 4040</b>												
367.7	4.1	3835	1.6	2.7	3888	1.1	1.4	3972	0.57	6000	4	
404.7	3.7	2928	1.1	2.5	2966	0.77	1.2	3029	0.39	6000		
460.3	3.3	3674	1.3	2.2	4000	0.91	1.1	4605	0.52	6000		
495.4	3.0	3874	1.2	2.0	3925	0.83	1.0	4008	0.42	6000		
581.3	2.6	3894	1.1	1.7	3944	0.71	0.86	4027	0.36	6000		
643.5	2.3	3907	0.95	1.6	3956	0.64	0.78	4039	0.33	6000		
691.5	2.2	4002	0.91	1.4	4348	0.66	0.72	4494	0.34	6000		
817.1	1.8	4142	0.80	1.2	4424	0.57	0.61	4516	0.29	6000		
879.4	1.7	3945	0.71	1.1	3994	0.48	0.57	4075	0.24	6000		
1017	1.5	3963	0.61	0.98	4011	0.41	0.49	4092	0.21	6000		
1142	1.3	3550	0.49	0.88	3593	0.33	0.44	3666	0.17	6000		
1304	1.2	2886	0.35	0.77	2961	0.24	0.38	3092	0.12	6000		
1430	1.0	4445	0.49	0.70	4498	0.33	0.35	4589	0.17	6000		
1539	0.97	3406	0.35	0.65	3494	0.24	0.32	3649	0.12	6000		
1806	0.83	3248	0.28	0.55	3304	0.19	0.28	3607	0.11	6000		
1999	0.75	3610	0.28	0.50	3652	0.19	0.25	3969	0.10	6000		
2268	0.66	4502	0.31	0.44	4781	0.22	0.22	5124	0.12	6000		
2502	0.60	4519	0.28	0.40	4572	0.19	0.20	4969	0.10	6000		
2904	0.52	4726	0.26	0.34	5112	0.18	0.17	5767	0.10	6000		
3170	0.47	4042	0.20	0.32	4382	0.15	0.16	5013	0.08	6000		

**1500**  
HOURS LIFE

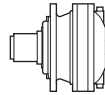

**040**

$i_{eff}$	1500			1000			500			$T_{2max}$ [Nm]	$P_T$ [kW]	
	$n_2$ [rpm]	$T_2$ [Nm]	$P_2$ [kW]	$n_2$ [rpm]	$T_2$ [Nm]	$P_2$ [kW]	$n_2$ [rpm]	$T_2$ [Nm]	$P_2$ [kW]			
<b>ED 2040</b>												
15.37	98	2477	25.3	65	2626	17.9	32.5	2800	9.5	5600	12	
17.47	86	2896	26.0	57	3031	18.2	28.6	3443	10.3	6000		
20.28	74	2654	20.6	49.3	2774	14.3	24.7	3136	8.1	6000		
22.70	66	2984	20.7	44.1	3119	14.4	22.0	3648	8.4	6000		
26.34	57	2732	16.3	38.0	2850	11.3	19.0	3323	6.6	6000		
31.02	48.4	2703	13.7	32.2	2925	9.9	16.1	3250	5.5	6000		
36.00	41.7	2823	12.3	27.8	3053	8.9	13.9	3555	5.2	6000		
41.64	36.0	2857	10.8	24.0	3077	7.7	12.0	3406	4.3	6000		
43.50	34.5	2444	8.8	23.0	2636	6.3	11.5	3082	3.7	6000		
50.32	29.8	2480	7.7	19.9	2726	5.7	9.9	3181	3.3	6000		
<b>ET 3040</b>												
59.06	25.4	3536	9.4	16.9	3860	6.8	8.5	4457	4.0	6000		8
61.28	24.5	3729	9.6	16.3	3821	6.5	8.2	3945	3.4	6000		
70.98	21.1	3221	7.1	14.1	3289	4.9	7.0	3383	2.5	6000		
83.76	17.9	3801	7.1	11.9	3881	4.9	6.0	3993	2.5	6000		
89.03	16.8	3410	6.0	11.2	3718	4.4	5.6	4287	2.5	6000		
96.88	15.5	3831	6.2	10.3	3906	4.2	5.2	4014	2.2	6000		
108.8	13.8	3442	5.0	9.2	3505	3.4	4.6	3599	1.7	6000		
124.2	12.1	2749	3.5	8.1	2840	2.4	4.0	2986	1.3	6000		
146.6	10.2	3244	3.5	6.8	3351	2.4	3.4	3524	1.3	6000		
157.5	9.5	4339	4.3	6.3	4414	2.9	3.2	4527	1.5	6000		
186.1	8.1	3538	3.0	5.4	3856	2.2	2.7	4134	1.2	6000		
198.9	7.5	2594	2.0	5.0	2878	1.5	2.5	3300	0.87	6000		
215.3	7.0	3611	2.6	4.6	3996	1.9	2.3	4195	1.0	6000		
249.0	6.0	3248	2.0	4.0	3603	1.5	2.0	4131	0.87	6000		
289.0	5.2	3769	2.0	3.5	4181	1.5	1.7	4794	0.87	6000		
325.7	4.6	4004	1.9	3.1	4117	1.3	1.5	4480	0.72	6000		
<b>EQ 4040</b>												
367.7	4.1	4047	1.7	2.7	4101	1.2	1.4	4461	0.64	6000	4	
404.7	3.7	3089	1.2	2.5	3238	0.84	1.2	3612	0.47	6000		
460.3	3.3	5066	1.7	2.2	5133	1.2	1.1	5584	0.64	6000		
495.4	3.0	4087	1.3	2.0	4188	0.89	1.0	4674	0.49	6000		
581.3	2.6	4107	1.1	1.7	4297	0.77	0.86	4791	0.43	6000		
643.5	2.3	4121	1.0	1.6	4367	0.71	0.78	4867	0.40	6000		
691.5	2.2	4585	1.0	1.4	4895	0.74	0.72	5458	0.41	6000		
817.1	1.8	4711	0.91	1.2	5027	0.64	0.61	5599	0.36	6000		
879.4	1.7	4303	0.77	1.1	4588	0.55	0.57	5105	0.30	6000		
1017	1.5	4404	0.68	0.98	4693	0.48	0.49	5218	0.27	6000		
1142	1.3	4114	0.57	0.88	4382	0.40	0.44	4869	0.22	6000		
1304	1.2	3349	0.40	0.77	3564	0.29	0.38	3960	0.16	6000		
1430	1.0	5151	0.57	0.70	5486	0.40	0.35	6095	0.22	6000		
1539	0.97	3952	0.40	0.65	4205	0.29	0.32	4673	0.16	6000		
1806	0.83	4071	0.35	0.55	4327	0.25	0.28	4791	0.14	6000		
1999	0.75	4487	0.35	0.50	4772	0.25	0.25	5290	0.14	6000		
2268	0.66	5786	0.40	0.44	6151	0.28	0.22	6814	0.16	6000		
2502	0.60	5617	0.35	0.40	5974	0.25	0.20	6623	0.14	6000		
2904	0.52	6519	0.35	0.34	6933	0.25	0.17	7612	0.14	6000		
3170	0.47	5827	0.29	0.32	6280	0.21	0.16	7121	0.12	6000		



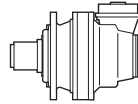

$i_{eff}$	1500			1000			500			$T_{2max}$ [Nm]	$P_T$ [kW]
	$n_2$ [rpm]	$T_2$ [Nm]	$P_2$ [kW]	$n_2$ [rpm]	$T_2$ [Nm]	$P_2$ [kW]	$n_2$ [rpm]	$T_2$ [Nm]	$P_2$ [kW]		

### EC 3040 - PDA 3040

35.49	42.3	1160	5.1	28.2	1310	3.9	14.1	1613	2.4	6000
41.88	35.8	1369	5.1	23.9	1546	3.9	11.9	1903	2.4	6000
46.09	32.5	1507	5.1	21.7	1702	3.9	10.8	2095	2.4	6000
52.42	28.6	1714	5.1	19.1	1935	3.9	9.5	2383	2.4	6000
54.39	27.6	1778	5.1	18.4	2008	3.9	9.2	2472	2.4	6000
60.84	24.7	1989	5.1	16.4	2246	3.9	8.2	2765	2.4	6000
68.09	22.0	2226	5.1	14.7	2514	3.9	7.3	3095	2.4	6000
79.02	19.0	2560	5.1	12.7	2664	3.5	6.3	2845	1.9	6000
88.66	16.9	1774	3.1	11.3	2003	2.4	5.6	2467	1.5	6000
99.17	15.1	1984	3.1	10.1	2241	2.4	5.0	2759	1.5	6000
111.0	13.5	2221	3.1	9.0	2508	2.4	4.5	3088	1.5	6000
128.8	11.6	2577	3.1	7.8	2791	2.3	3.9	3118	1.3	6000
140.2	10.7	2023	2.3	7.1	2130	1.6	3.6	2310	0.86	6000
151.7	9.9	2826	2.9	6.6	2973	2.1	3.3	3219	1.1	6000
176.0	8.5	2767	2.5	5.7	2873	1.7	2.8	3336	0.99	6000
203.6	7.4	2805	2.2	4.9	2960	1.5	2.5	3356	0.86	6000
215.8	7.0	2391	1.7	4.6	2486	1.2	2.3	2894	0.70	6000
244.1	6.1	2853	1.8	4.1	3081	1.3	2.0	3576	0.77	6000
282.3	5.3	2908	1.6	3.5	3181	1.2	1.8	3480	0.65	6000

5

### EC 4040 - PDA 4040

319.9	4.7	3817	1.9	3.1	3870	1.3	1.6	3956	0.65	6000
347.1	4.3	3262	1.5	2.9	3306	1.0	1.4	3377	0.51	6000
401.5	3.7	3278	1.3	2.5	3321	0.87	1.2	3392	0.44	6000
473.7	3.2	3868	1.3	2.1	3919	0.87	1.1	4002	0.44	6000
481.2	3.1	3298	1.1	2.1	3340	0.73	1.0	3410	0.37	6000
567.9	2.6	3891	1.1	1.8	3941	0.73	0.88	4024	0.37	6000
656.8	2.3	3909	0.94	1.5	3959	0.63	0.76	4041	0.32	6000
716.7	2.1	3242	0.71	1.4	3329	0.49	0.70	3479	0.25	6000
822.2	1.8	4147	0.79	1.2	4502	0.57	0.61	5059	0.32	6000
930.9	1.6	3528	0.60	1.1	3572	0.40	0.54	3645	0.21	6000
993.8	1.5	3312	0.52	1.0	3399	0.36	0.50	3551	0.19	6000
1165	1.3	4417	0.60	0.86	4471	0.40	0.43	4563	0.21	6000
1291	1.2	3563	0.43	0.77	3606	0.29	0.39	3704	0.15	6000
1352	1.1	4059	0.47	0.74	4403	0.34	0.37	5043	0.20	6000
1616	0.93	4461	0.43	0.62	4514	0.29	0.31	4637	0.15	6000
1848	0.81	4322	0.37	0.54	4683	0.27	0.27	4963	0.14	6000
1959	0.77	3815	0.31	0.51	4218	0.23	0.26	4817	0.13	6000
2208	0.68	4043	0.29	0.45	4134	0.20	0.23	4500	0.11	6000
2563	0.59	4611	0.28	0.39	4798	0.20	0.20	5222	0.11	6000
2964	0.51	4227	0.22	0.34	4616	0.16	0.17	5138	0.09	6000
3097	0.48	4023	0.20	0.32	4362	0.15	0.16	4991	0.08	6000

3

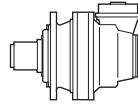

$i_{eff}$	1500			1000			500			$T_{2max}$ [Nm]	$P_T$ [kW]
	$n_2$ [rpm]	$T_2$ [Nm]	$P_2$ [kW]	$n_2$ [rpm]	$T_2$ [Nm]	$P_2$ [kW]	$n_2$ [rpm]	$T_2$ [Nm]	$P_2$ [kW]		

**EC 3040 - PDA 3040**

35.49	42.3	2050	9.1	28.2	2315	6.8	14.1	2850	4.2	6000	
41.88	35.8	2419	9.1	23.9	2731	6.8	11.9	3363	4.2	6000	
46.09	32.5	2662	9.1	21.7	2873	6.5	10.8	2971	3.4	6000	
52.42	28.6	3028	9.1	19.1	3419	6.8	9.5	4210	4.2	6000	
54.39	27.6	3141	9.1	18.4	3390	6.5	9.2	3505	3.4	6000	
60.84	24.7	3136	8.1	16.4	3429	5.9	8.2	3967	3.4	6000	
68.09	22.0	3648	8.4	14.7	3978	6.1	7.3	4388	3.4	6000	
79.02	19.0	3323	6.6	12.7	3626	4.8	6.3	4185	2.8	6000	
88.66	16.9	3134	5.6	11.3	3474	4.1	5.6	3573	2.1	6000	
99.17	15.1	3491	5.5	10.1	3803	4.0	5.0	4380	2.3	6000	5
111.0	13.5	3924	5.6	9.0	4350	4.1	4.5	4472	2.1	6000	
128.8	11.6	3690	4.5	7.8	4014	3.3	3.9	4614	1.9	6000	
140.2	10.7	2491	2.8	7.1	2632	2.0	3.6	3129	1.2	6000	
151.7	9.9	3455	3.6	6.6	3662	2.5	3.3	4107	1.4	6000	
176.0	8.5	3938	3.5	5.7	4251	2.5	2.8	4767	1.4	6000	
203.6	7.4	3619	2.8	4.9	3824	2.0	2.5	4546	1.2	6000	
215.8	7.0	3433	2.5	4.6	3736	1.8	2.3	4298	1.0	6000	
244.1	6.1	4166	2.7	4.1	4565	2.0	2.0	4851	1.0	6000	
282.3	5.3	3759	2.1	3.5	4157	1.5	1.8	4777	0.89	6000	

**EC 4040 - PDA 4040**

319.9	4.7	4027	2.0	3.1	4082	1.3	1.6	4363	0.71	6000	
347.1	4.3	3442	1.6	2.9	3487	1.1	1.4	3845	0.58	6000	
401.5	3.7	3458	1.4	2.5	3524	0.92	1.2	3933	0.51	6000	
473.7	3.2	4081	1.4	2.1	4158	0.92	1.1	4641	0.51	6000	
481.2	3.1	3478	1.1	2.1	3628	0.79	1.0	4045	0.44	6000	
567.9	2.6	4104	1.1	1.8	4281	0.79	0.88	4774	0.44	6000	
656.8	2.3	4123	0.99	1.5	4381	0.70	0.76	4882	0.39	6000	
716.7	2.1	3642	0.80	1.4	3740	0.55	0.70	4160	0.30	6000	
822.2	1.8	5162	0.99	1.2	5485	0.70	0.61	6112	0.39	6000	
930.9	1.6	3984	0.67	1.1	4246	0.48	0.54	4721	0.27	6000	
993.8	1.5	3720	0.59	1.0	3933	0.41	0.50	4372	0.23	6000	3
1165	1.3	4987	0.67	0.86	5315	0.48	0.43	5910	0.27	6000	
1291	1.2	4194	0.51	0.77	4465	0.36	0.39	4958	0.20	6000	
1352	1.1	5788	0.67	0.74	6168	0.48	0.37	6859	0.27	6000	
1616	0.93	5250	0.51	0.62	5590	0.36	0.31	6207	0.20	6000	
1848	0.81	5608	0.48	0.54	5965	0.34	0.27	6613	0.19	6000	
1959	0.77	5446	0.44	0.51	5792	0.31	0.26	6423	0.17	6000	
2208	0.68	5079	0.36	0.45	5397	0.26	0.23	5977	0.14	6000	
2563	0.59	5894	0.36	0.39	6264	0.26	0.20	6937	0.14	6000	
2964	0.51	5800	0.31	0.34	6163	0.22	0.17	6824	0.12	6000	
3097	0.48	5802	0.29	0.32	6253	0.21	0.16	7092	0.12	6000	

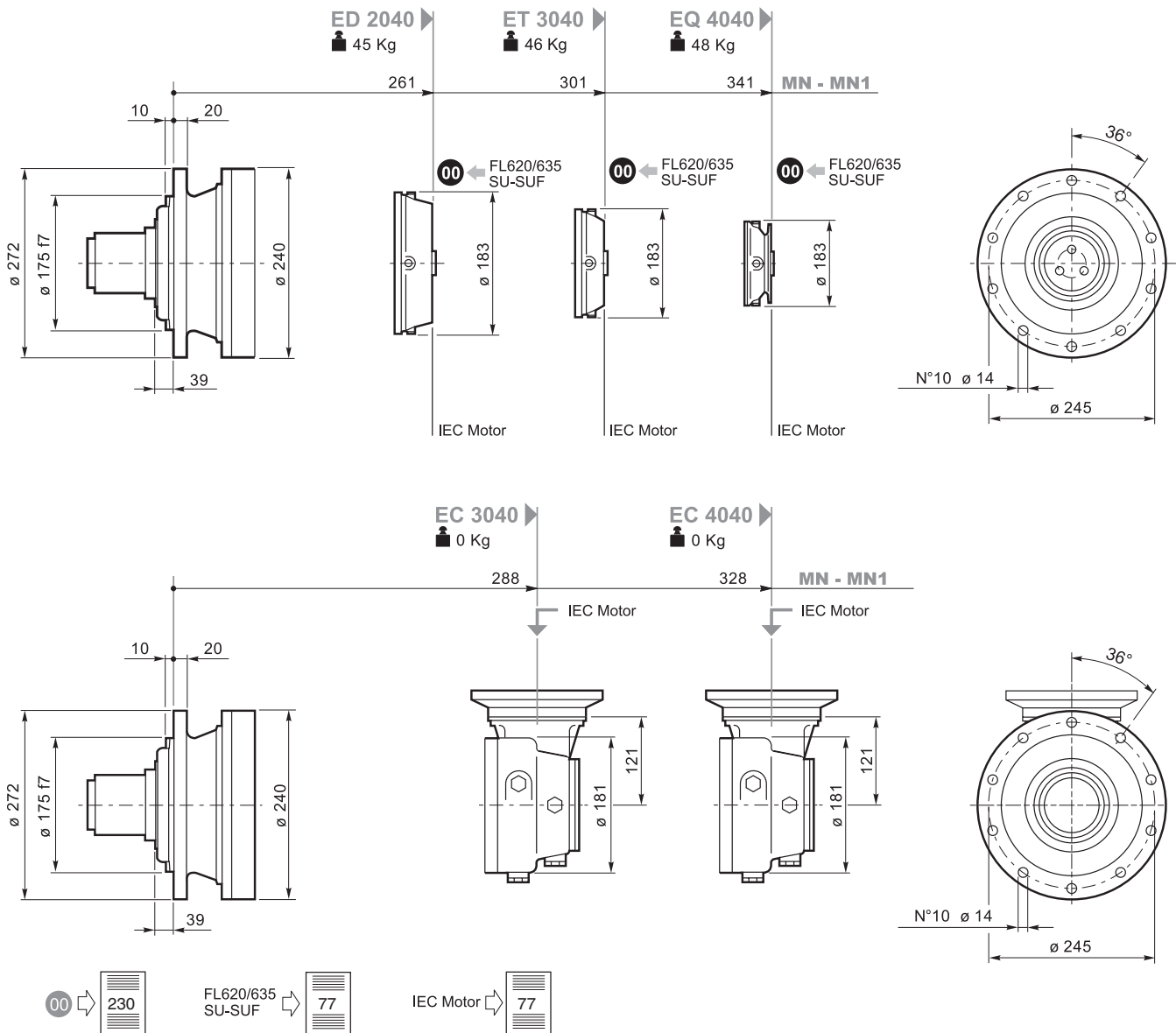
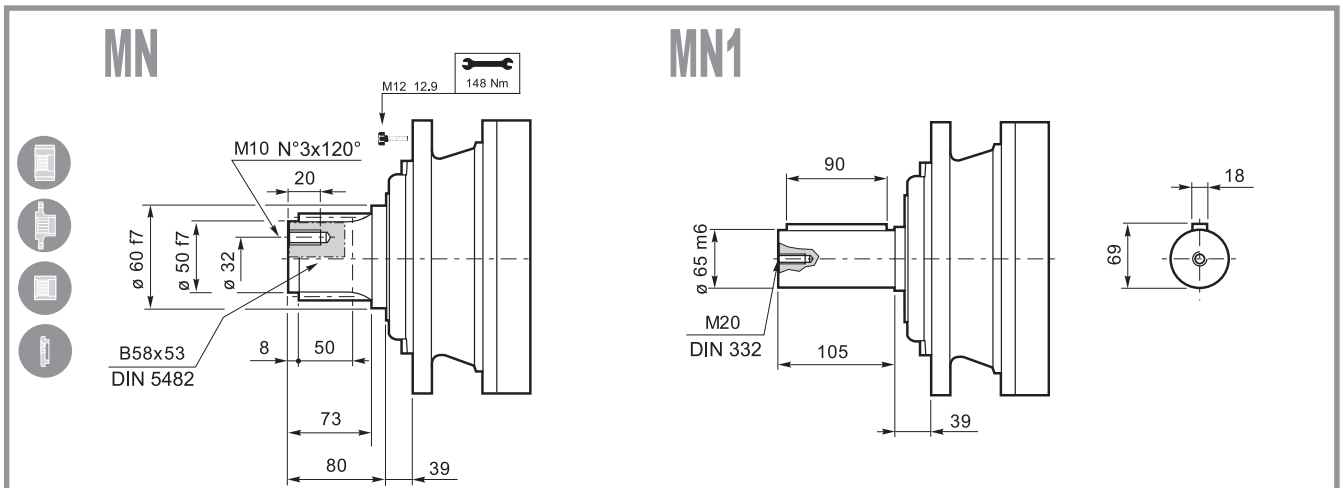

## SU2

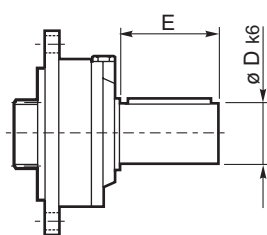

SU 2	D k6	E	Lt	
			ED 2040	MN-MN1
	40	58	ET 3040	321
			EQ 4040	372
				412

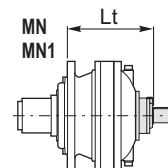

## FL620/10-FL635/10

## FL620U-FL635U

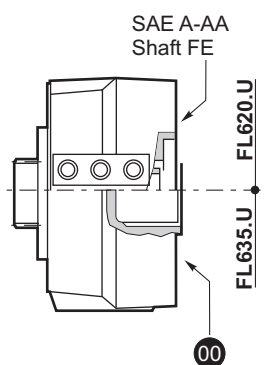

		Lt	
		ED 2040	MN-MN1
FL620/U	ED 2040	365.5	
	ET 3040	405.5	
	EQ 4040	445.5	
FL635U	ED 2040	352	
	ET 3040	392	
	EQ 4040	432	
FL620/10	ED 2040	325	
	ET 3040	365	
	EQ 4040	405	
FL635/10	ED 2040	306	
	ET 3040	346	
	EQ 4040	386	

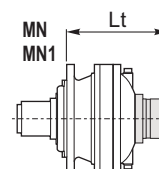

## IEC Motor

		Lt				
		IEC 63	IEC 71	IEC 80 90	IEC 100 112	IEC 132
ED 2040	MN-MN1	281	283	288	289	356
ET 3040	MN-MN1	321	323	328	329	396
EQ 4040	MN-MN1	361	363	368	369	436
EC 3040	MN-MN1	151	151	151	151	238
EC 4040	MN-MN1	151	151	151	151	238

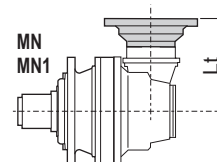
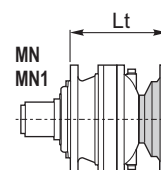



**Flangia ruota**  
Driving flange  
Radnabenflansch  
Flasque de roue  
Brida de la rueda  
Flange de roda

**FA 045**

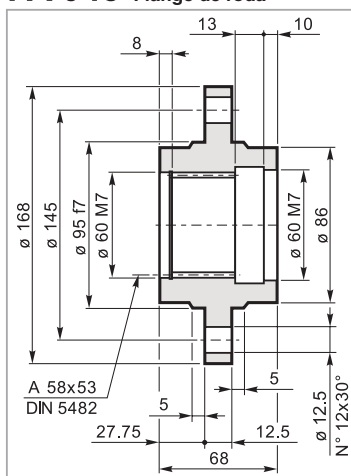

Mat. C40 UNI EN 10083  
Code: 34700641800



**Flangia ruota**  
Driving flange  
Radnabenflansch  
Flasque de roue  
Brida de la rueda  
Flange de roda

**FR 045**

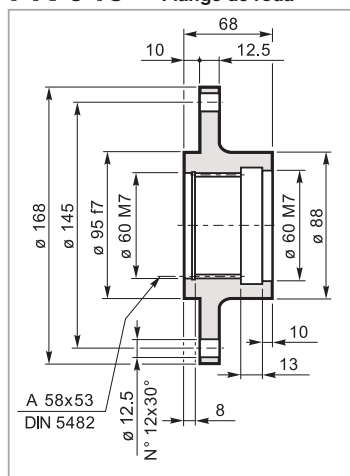

Mat. C40 UNI EN 10083  
Code: 34700131800



**Pignoni**  
Pinion  
Ritzel  
Pignon  
Piñones  
Pinhões

**IR 045**

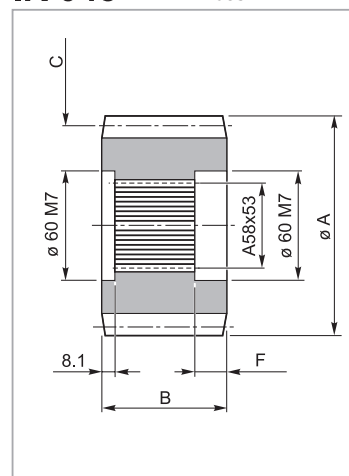

**Manicotto scanalato**  
Splined bush  
Keilmuffe  
Manchon cannelée  
Manguito acanalado  
Luva ranhurada

**MS 045**

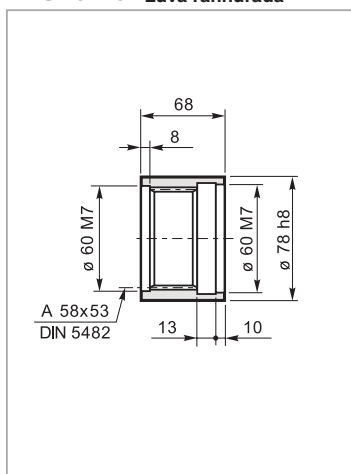

Mat. 39NiCrMo3 UNI EN 10083  
Code: 39102840600



**Rondella di fermo**  
Shaft cover  
Gegenseibe  
Rondelle frein  
Arandela de bloqueo  
Amuela de encosto

**RDF 045**

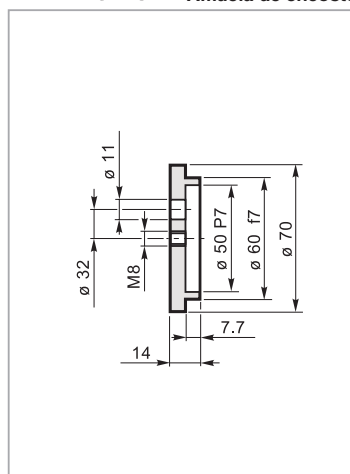

Mat. C40 UNI EN 10083  
Code: 37201040800

code	A	B	C	F
335.0143.0800	114.8	68	M=8 Z=12 X=0.3	23.5
335.0174.0800	99.6	68	M=6 Z=14 X=0.3	24
335.0184.0800	114.8	80	M=8 Z=12 X=0.3	24
335.0274.0800	143	80	M=10 Z=12 X=0.35	23.5
335.0324.0800	136.2	80	M=8 Z=15 —	23.5
335.0344.0800	152	80	M=10 Z=13 X=0.3	23.5
335.0353.000K	127.6	68	M=8 Z=13 X=0.54	23.5
335.2133.0600	143.4	80	M=8 Z=15 X=0.4	23.5
335.3473.0600	156	80	M=6 Z=24 —	23
335.4273.0600	142	80	M=8 Z=16 —	23.5
335.5193.060	115	68	M=5 Z=21 —	24
335.5942.000	136	80	M=8 Z=14 X=0.4	23.5
335.6273.000	120	68	M=8 Z=13 —	24



**Barra scanalata**  
Splined bar  
Zugspindel  
Barre cannelée  
Barra acanalada  
Barra ranhurada

**BS 045**

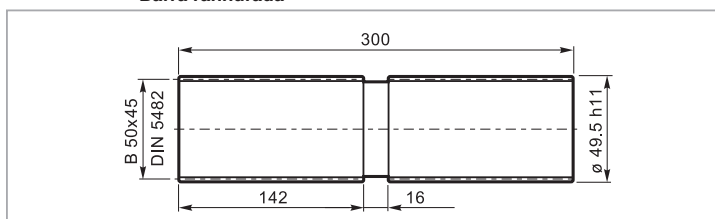

Mat. 39NiCrMo3 UNI EN 10083  
Code: 39126930100

Carichi radiali sugli alberi uscita / Radial loads on output shafts  
 Radiallasten auf de Abtriebswellen / Charges radiales sur les arbres de sortie  
 Cargas sobre los ejes de salida / Cargas radiais nos eixos de saida

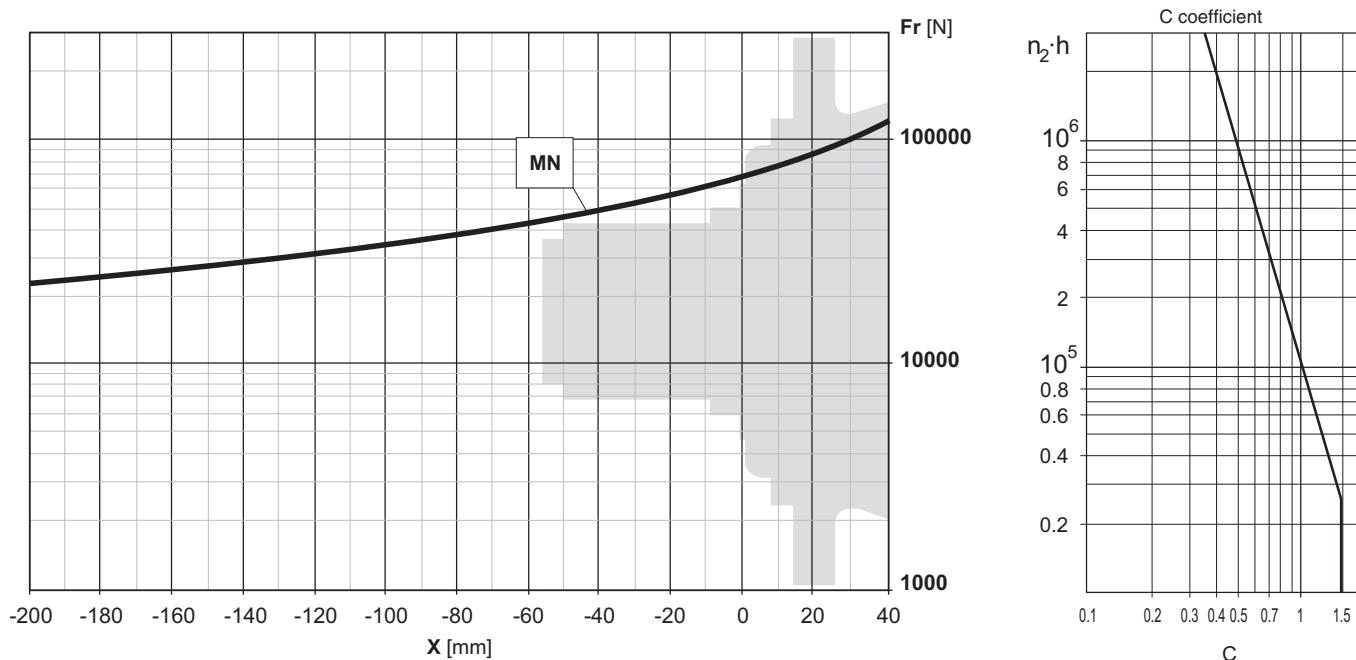

Carichi assiali / Axial loads / Axialkräfte / Charges axiales / Cargas axiales / Forças axiais

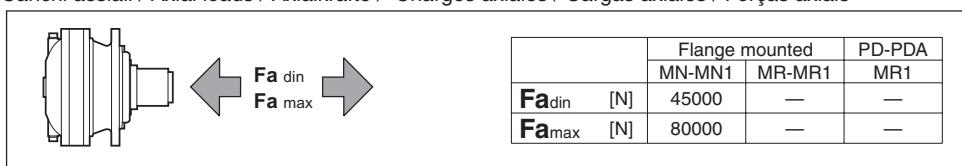

Carichi radiali sugli alberi entrata / Radial loads on input shafts  
 Radiallasten auf de Antriebswellen / Charges radiales sur les arbres d'entrée  
 Cargas sobre los ejes de entrada / Cargas radiais nos eixos de entrada

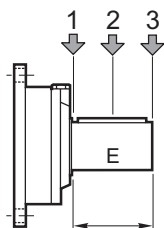

Type	E	$Fr$ [N]					
		$n_1 \cdot h = 10^7$			$n_1 \cdot h = 10^8$		
		1	2	3	1	2	3
SU2	58	3000	2000	1500	1400	1000	700

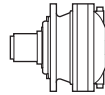

i <sub>eff</sub>	1500			1000			500			T <sub>2max</sub> [Nm]	P <sub>T</sub> [kW]
	n <sub>2</sub> [rpm]	T <sub>2</sub> [Nm]	P <sub>2</sub> [kW]	n <sub>2</sub> [rpm]	T <sub>2</sub> [Nm]	P <sub>2</sub> [kW]	n <sub>2</sub> [rpm]	T <sub>2</sub> [Nm]	P <sub>2</sub> [kW]		
<b>EM 1045</b>											
3.50	429	1565	70	286	1767	53	143	2175	32.6	6000	20
4.13	363	1617	62	242	1827	46.3	121	2249	28.5	6000	
5.17	290	1682	51	193	1900	38.5	97	2339	23.7	6000	
6.00	250	1732	45.4	167	1956	34.1	83	2173	19.0	6000	
7.25	207	1582	34.3	138	1695	24.5	69	1868	13.5	6000	
<b>ED 2045</b>											
10.78	139	2193	32.0	93	2476	24.1	46.4	3049	14.8	6000	15
12.25	122	2278	29.2	82	2573	22.0	40.8	3168	13.5	6000	
14.46	104	2394	26.0	69	2704	19.6	34.6	3329	12.1	6000	
17.06	88	2475	22.8	59	2795	17.2	29.3	3393	10.4	6000	
18.10	83	2561	22.2	55	2893	16.7	27.6	3562	10.3	6000	
21.00	71	2678	20.0	47.6	3025	15.1	23.8	3724	9.3	6000	
25.38	59	2835	17.6	39.4	3202	13.2	19.7	3553	7.3	6000	
29.94	50	2931	15.4	33.4	3310	11.6	16.7	3583	6.3	6000	
31.02	48.4	2582	13.1	32.2	2698	9.1	16.1	2893	4.9	6000	
36.00	41.7	2358	10.3	27.8	2463	7.2	13.9	2640	3.8	6000	
43.50	34.5	2407	8.7	23.0	2511	6.0	11.5	2689	3.2	6000	
52.56	28.5	2070	6.2	19.0	2161	4.3	9.5	2319	2.3	6000	
<b>ET 3045</b>											
53.78	27.9	3552	10.4	18.6	3961	7.7	9.3	4314	4.2	6000	10
63.46	23.6	3732	9.2	15.8	4022	6.6	7.9	4469	3.7	6000	
73.50	20.4	3901	8.3	13.6	4077	5.8	6.8	4609	3.3	6000	
79.44	18.9	3955	7.8	12.6	4106	5.4	6.3	4684	3.1	6000	
92.19	16.3	4010	6.8	10.8	4174	4.7	5.4	4831	2.7	6000	
100.3	15.0	4042	6.3	10.0	4250	4.4	5.0	4915	2.6	6000	
108.6	13.8	4071	5.9	9.2	4323	4.2	4.6	4996	2.4	6000	
125.6	11.9	4125	5.2	8.0	4459	3.7	4.0	5146	2.1	6000	
145.7	10.3	4221	4.6	6.9	4601	3.3	3.4	5088	1.8	6000	
152.3	9.9	3846	4.0	6.6	4014	2.8	3.3	4302	1.5	6000	
176.1	8.5	3907	3.5	5.7	4074	2.4	2.8	4363	1.3	6000	
207.8	7.2	3970	3.0	4.8	4326	2.2	2.4	4941	1.2	6000	
224.2	6.7	4035	2.8	4.5	4395	2.1	2.2	4798	1.1	6000	
260.2	5.8	4165	2.5	3.8	4532	1.8	1.9	4970	1.0	6000	
280.7	5.3	3302	1.8	3.6	3605	1.3	1.8	4167	0.78	6000	
314.4	4.8	4334	2.2	3.2	4711	1.6	1.6	5022	0.84	6000	
364.8	4.1	2542	1.1	2.7	2788	0.80	1.4	3244	0.47	6000	
<b>EQ 4045</b>											
404.7	3.7	5051	2.0	2.5	5245	1.4	1.2	5615	0.73	6000	6
441.0	3.4	5312	1.9	2.3	5418	1.3	1.1	5684	0.68	6000	
510.1	2.9	5382	1.7	2.0	5439	1.1	0.98	5803	0.60	6000	
551.3	2.7	5393	1.5	1.8	5449	1.0	0.91	5867	0.56	6000	
639.8	2.3	5270	1.3	1.6	5470	0.90	0.78	5992	0.49	6000	
696.2	2.2	5425	1.2	1.4	5495	0.83	0.72	6064	0.46	6000	
773.1	1.9	4524	0.92	1.3	4698	0.64	0.65	5463	0.37	6000	
913.5	1.6	4595	0.79	1.1	4866	0.56	0.55	5662	0.33	6000	
1011	1.5	5477	0.85	0.99	5796	0.60	0.49	6389	0.33	6000	
1140	1.3	5565	0.77	0.88	5895	0.54	0.44	6496	0.30	6000	
1222	1.2	4743	0.61	0.82	5190	0.45	0.41	6021	0.26	6000	
1442	1.0	5337	0.58	0.69	5652	0.41	0.35	6226	0.23	6000	
1599	0.94	5036	0.50	0.63	5502	0.36	0.31	6366	0.21	6000	
1849	0.81	5200	0.44	0.54	5676	0.32	0.27	6559	0.19	6000	
1995	0.75	4415	0.35	0.50	4530	0.24	0.25	4730	0.12	6000	
2315	0.65	5124	0.35	0.43	5257	0.24	0.22	5489	0.12	6000	
2623	0.57	4633	0.28	0.38	5013	0.20	0.19	5720	0.11	6000	
2798	0.54	5687	0.32	0.36	6193	0.23	0.18	6633	0.12	6000	
3301	0.45	5997	0.29	0.30	6343	0.20	0.15	6975	0.11	6000	

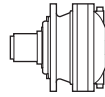

$i_{eff}$	1500			1000			500			$T_{2max}$ [Nm]	$P_T$ [kW]	
	$n_2$ [rpm]	$T_2$ [Nm]	$P_2$ [kW]	$n_2$ [rpm]	$T_2$ [Nm]	$P_2$ [kW]	$n_2$ [rpm]	$T_2$ [Nm]	$P_2$ [kW]			
<b>EM 1045</b>												
3.50	429	2764	124	286	3122	93	143	3773	56	6000	20	
4.13	363	2858	109	242	3112	79	121	3449	43.7	6000		
5.17	290	2411	73	193	2592	53	97	2855	28.9	6000		
6.00	250	2238	59	167	2391	41.7	83	2618	22.8	6000		
7.25	207	1953	42.3	138	2077	30.0	69	2267	16.4	6000		
<b>ED 2045</b>												
10.78	139	3786	55	93	3980	38.7	46.4	4542	22.1	6000	15	
12.25	122	3849	49.4	82	4038	34.5	40.8	4671	20.0	6000		
14.46	104	3928	42.7	69	4147	30.0	34.6	4841	17.5	6000		
17.06	88	3585	33.0	59	3753	23.0	29.3	4381	13.5	6000		
18.10	83	4031	35.0	55	4368	25.3	27.6	5077	14.7	6000		
21.00	71	4116	30.8	47.6	4516	22.5	23.8	4974	12.4	6000		
25.38	59	3705	22.9	39.4	3933	16.2	19.7	4283	8.8	6000		
29.94	50	3892	20.4	33.4	4260	14.9	16.7	4921	8.6	6000		
31.02	48.4	3085	15.6	32.2	3352	11.3	16.1	3901	6.6	6000		
36.00	41.7	2823	12.3	27.8	3053	8.9	13.9	3555	5.2	6000		
43.50	34.5	2905	10.5	23.0	3186	7.7	11.5	3700	4.5	6000		
52.56	28.5	2504	7.5	19.0	2753	5.5	9.5	3211	3.2	6000		
<b>ET 3045</b>												
53.78	27.9	5067	14.8	18.6	5371	10.5	9.3	5509	5.4	6000	10	
63.46	23.6	5244	13.0	15.8	5397	8.9	7.9	5643	4.7	6000		
73.50	20.4	5356	11.4	13.6	5419	7.7	6.8	5763	4.1	6000		
79.44	18.9	5369	10.6	12.6	5431	7.2	6.3	5828	3.8	6000		
92.19	16.3	5186	8.8	10.8	5404	6.1	5.4	5953	3.4	6000		
100.3	15.0	5405	8.5	10.0	5466	5.7	5.0	6024	3.1	6000		
108.6	13.8	5417	7.8	9.2	5517	5.3	4.6	6092	2.9	6000		
125.6	11.9	5439	6.8	8.0	5634	4.7	4.0	6218	2.6	6000		
145.7	10.3	5452	5.9	6.9	5756	4.1	3.4	6350	2.3	6000		
152.3	9.9	4609	4.8	6.6	4961	3.4	3.3	5779	2.0	6000		
176.1	8.5	4677	4.2	5.7	5127	3.0	2.8	5961	1.8	6000		
207.8	7.2	5299	4.0	4.8	5616	2.8	2.4	6189	1.6	6000		
224.2	6.7	4963	3.5	4.5	5127	2.4	2.2	5390	1.3	6000		
260.2	5.8	5473	3.3	3.8	5797	2.3	1.9	6256	1.3	6000		
280.7	5.3	4887	2.7	3.6	5290	2.0	1.8	6039	1.1	6000		
314.4	4.8	5622	2.8	3.2	5953	2.0	1.6	6554	1.1	6000		
364.8	4.1	3829	1.6	2.7	4156	1.2	1.4	4763	0.68	6000		
<b>EQ 4045</b>												
404.7	3.7	6281	2.4	2.5	6647	1.7	1.2	7312	0.95	6000		6
441.0	3.4	6357	2.3	2.3	6727	1.6	1.1	7398	0.88	6000		
510.1	2.9	6488	2.0	2.0	6863	1.4	0.98	7546	0.78	6000		
551.3	2.7	6559	1.9	1.8	6937	1.3	0.91	7626	0.72	6000		
639.8	2.3	6696	1.6	1.6	7080	1.2	0.78	7781	0.64	6000		
696.2	2.2	6774	1.5	1.4	7163	1.1	0.72	7870	0.59	6000		
773.1	1.9	6455	1.3	1.3	7012	0.95	0.65	7982	0.54	6000		
913.5	1.6	6680	1.1	1.1	7251	0.83	0.55	8163	0.47	6000		
1011	1.5	7132	1.1	0.99	7537	0.78	0.49	8275	0.43	6000		
1140	1.3	7249	1.0	0.88	7660	0.70	0.44	8408	0.39	6000		
1222	1.2	7086	0.91	0.82	7682	0.66	0.41	8487	0.36	6000		
1442	1.0	6946	0.76	0.69	7338	0.53	0.35	8053	0.29	6000		
1599	0.94	7477	0.74	0.63	8018	0.53	0.31	8795	0.29	6000		
1849	0.81	7695	0.65	0.54	8176	0.46	0.27	8966	0.25	6000		
1995	0.75	5123	0.40	0.50	5451	0.29	0.25	6058	0.16	6000		
2315	0.65	5945	0.40	0.43	6326	0.29	0.22	7031	0.16	6000		
2623	0.57	6490	0.39	0.38	6852	0.27	0.19	7511	0.15	6000		
2798	0.54	7184	0.40	0.36	7644	0.29	0.18	8495	0.16	6000		
3301	0.45	7767	0.37	0.30	8199	0.26	0.15	8984	0.14	6000		



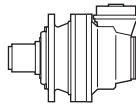

$i_{eff}$	1500			1000			500			$T_{2max}$ [Nm]	$P_T$ [kW]
	$n_2$ [rpm]	$T_2$ [Nm]	$P_2$ [kW]	$n_2$ [rpm]	$T_2$ [Nm]	$P_2$ [kW]	$n_2$ [rpm]	$T_2$ [Nm]	$P_2$ [kW]		

**EC 2045 - PDA 2045**

10.50	143	2175	32.6	95	2457	24.5	47.6	3025	15.1	6000	10
12.39	121	2249	28.5	81	2540	21.5	40.4	3127	13.2	6000	
16.17	93	1582	15.4	62	1787	11.6	30.9	2200	7.1	6000	
18.00	83	2173	19.0	56	2283	13.3	27.8	2463	7.2	6000	
19.08	79	1867	15.4	52	2109	11.6	26.2	2596	7.1	6000	
21.75	69	1868	13.5	46.0	1962	9.4	23.0	2119	5.1	6000	
23.89	63	2337	15.4	41.9	2624	11.5	20.9	2820	6.2	6000	
27.72	54	2290	13.0	36.1	2396	9.1	18.0	2573	4.9	6000	
33.50	44.8	1968	9.2	29.9	2060	6.4	14.9	2216	3.5	6000	

**EC 3045 - PDA 3045**

36.75	40.8	3168	13.5	27.2	3578	10.2	13.6	4077	5.8	6000	7
43.37	34.6	3329	12.1	23.1	3760	9.1	11.5	4138	5.0	6000	
49.80	30.1	3471	10.9	20.1	3920	8.2	10.0	4244	4.5	6000	
56.60	26.5	3606	10.0	17.7	3980	7.4	8.8	4362	4.0	6000	
63.00	23.8	3724	9.3	15.9	4020	6.7	7.9	4462	3.7	6000	
73.57	20.4	2827	6.0	13.6	2941	4.2	6.8	3139	2.2	6000	
83.60	17.9	3974	7.5	12.0	4125	5.2	6.0	4734	3.0	6000	
89.83	16.7	3583	6.3	11.1	3719	4.3	5.6	4196	2.4	6000	
97.02	15.5	4029	6.5	10.3	4220	4.6	5.2	4882	2.6	6000	
114.5	13.1	3664	5.0	8.7	3810	3.5	4.4	4414	2.0	6000	
123.5	12.1	2973	3.8	8.1	3088	2.6	4.0	3508	1.5	6000	
138.3	10.8	3728	4.2	7.2	3969	3.0	3.6	4590	1.7	6000	
166.3	9.0	2752	2.6	6.0	2858	1.8	3.0	3296	1.0	6000	
173.2	8.7	3069	2.8	5.8	3246	2.0	2.9	3770	1.1	6000	
201.0	7.5	2801	2.2	5.0	2951	1.5	2.5	3432	0.89	6000	
242.8	6.2	2419	1.6	4.1	2541	1.1	2.1	2970	0.64	6000	

**EC 4045 - PDA 4045**

276.6	5.4	4831	2.7	3.6	5063	1.9	1.8	5396	1.0	6000	3
310.3	4.8	4946	2.5	3.2	5369	1.8	1.6	5466	0.92	6000	
347.1	4.3	4978	2.3	2.9	5171	1.6	1.4	5493	0.83	6000	
414.7	3.6	5246	2.0	2.4	5410	1.4	1.2	5635	0.71	6000	
450.8	3.3	5103	1.8	2.2	5297	1.2	1.1	5702	0.66	6000	
498.3	3.0	5379	1.7	2.0	5435	1.1	1.0	5784	0.61	6000	
570.0	2.6	4066	1.1	1.8	4179	0.77	0.88	4372	0.40	6000	
625.0	2.4	5259	1.3	1.6	5456	0.91	0.80	5972	0.50	6000	
712.7	2.1	5322	1.2	1.4	5514	0.81	0.70	6084	0.45	6000	
799.3	1.9	4538	0.89	1.3	4722	0.62	0.63	5502	0.36	6000	
929.1	1.6	4202	0.71	1.1	4315	0.49	0.54	4509	0.25	6000	
988.1	1.5	5474	0.87	1.0	5777	0.61	0.51	6368	0.34	6000	
1078	1.4	4877	0.71	0.93	5008	0.49	0.46	5233	0.25	6000	
1194	1.3	4718	0.62	0.84	5164	0.45	0.42	5991	0.26	6000	
1409	1.1	5319	0.59	0.71	5633	0.42	0.35	6206	0.23	6000	
1593	0.94	4738	0.47	0.63	5130	0.34	0.31	5859	0.19	6000	
1806	0.83	5174	0.45	0.55	5648	0.33	0.28	6455	0.19	6000	
1925	0.78	4918	0.40	0.52	5322	0.29	0.26	6072	0.17	6000	
2208	0.68	5052	0.36	0.45	5465	0.26	0.23	6231	0.15	6000	
2563	0.59	4611	0.28	0.39	4990	0.20	0.20	5695	0.12	6000	
2668	0.56	5242	0.31	0.37	5666	0.22	0.19	6428	0.13	6000	
3097	0.48	4785	0.24	0.32	5176	0.18	0.16	5900	0.10	6000	

Tutti i rapporti evidenziati (es. 10.50) hanno dimensioni particolari della coppia conica in certe versioni; vedere tavole dimensionali.

All ratios grey highlighted (ex. 10.50) have specific dimensions of the bevel gear set in some versions; see dimensional tables.

Alle mit (es. 10.50) gekennzeichneten Übersetzungen haben in bestimmten Versionen besondere Dimensionen des Kegelradtriebs. Siehe auch Dimensionstabellen.

Les rapports repérés par (es. 10.50) ont des dimensions de couple conique particulières. Voir les tableaux dimensionnels.

Todas las relaciones indicadas con (es. 10.50) tienen dimensiones particulares del par cónico según las versiones; ver las tablas de dimensión.

As relações marcadas com (es. 10.50) têm dimensões particulares da engrenagem cônica em certas versões; vide tabelas dimensionais.



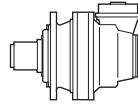

$i_{eff}$	1500			1000			500			$T_{2max}$ [Nm]	$P_T$ [kW]
	$n_2$ [rpm]	$T_2$ [Nm]	$P_2$ [kW]	$n_2$ [rpm]	$T_2$ [Nm]	$P_2$ [kW]	$n_2$ [rpm]	$T_2$ [Nm]	$P_2$ [kW]		

**EC 2045 - PDA 2045**

10.50	143	3773	56	95	3968	39.6	47.6	4516	22.5	6000	10
12.39	121	3449	43.7	81	3620	30.6	40.4	4086	17.3	6000	
16.17	93	2796	27.2	62	3157	20.5	30.9	3887	12.6	6000	
18.00	83	2618	22.8	56	2739	15.9	27.8	3053	8.9	6000	
19.08	79	3299	27.2	52	3726	20.5	26.2	4488	12.3	6000	
21.75	69	2267	16.4	46.0	2371	11.4	23.0	2636	6.3	6000	
23.89	63	3001	19.7	41.9	3156	13.8	20.9	3688	8.1	6000	
27.72	54	2747	15.6	36.1	2875	10.9	18.0	3360	6.3	6000	
33.50	44.8	2378	11.2	29.9	2480	7.8	14.9	2908	4.5	6000	

**EC 3045 - PDA 3045**

36.75	40.8	4671	20.0	27.2	5093	14.5	13.6	5419	7.7	6000	7
43.37	34.6	4841	17.5	23.1	5271	12.7	11.5	5444	6.6	6000	
49.80	30.1	4986	15.7	20.1	5359	11.3	10.0	5465	5.7	6000	
56.60	26.5	5121	14.2	17.7	5379	10.0	8.8	5550	5.1	6000	
63.00	23.8	4974	12.4	15.9	5200	8.6	7.9	5637	4.7	6000	
73.57	20.4	3709	7.9	13.6	4043	5.8	6.8	4659	3.3	6000	
83.60	17.9	5377	10.1	12.0	5439	6.8	6.0	5870	3.7	6000	
89.83	16.7	4921	8.6	11.1	4977	5.8	5.6	5500	3.2	6000	
97.02	15.5	5214	8.4	10.3	5450	5.9	5.2	5996	3.2	6000	
114.5	13.1	4955	6.8	8.7	5155	4.7	4.4	5693	2.6	6000	
123.5	12.1	4139	5.3	8.1	4497	3.8	4.0	5161	2.2	6000	
138.3	10.8	4995	5.7	7.2	5298	4.0	3.6	5847	2.2	6000	
166.3	9.0	3892	3.7	6.0	4228	2.7	3.0	4851	1.5	6000	
173.2	8.7	4437	4.0	5.8	4813	2.9	2.9	5509	1.7	6000	
201.0	7.5	4046	3.2	5.0	4392	2.3	2.5	5032	1.3	6000	
242.8	6.2	3520	2.3	4.1	3828	1.7	2.1	4399	0.95	6000	

**EC 4045 - PDA 4045**

276.6	5.4	5953	3.4	3.6	6303	2.4	1.8	6940	1.3	6000	3
310.3	4.8	6050	3.1	3.2	6406	2.2	1.6	7051	1.2	6000	
347.1	4.3	6147	2.8	2.9	6507	2.0	1.4	7160	1.1	6000	
414.7	3.6	6303	2.4	2.4	6669	1.7	1.2	7336	0.93	6000	
450.8	3.3	6377	2.2	2.2	6747	1.6	1.1	7420	0.86	6000	
498.3	3.0	6467	2.0	2.0	6841	1.4	1.0	7522	0.79	6000	
570.0	2.6	4568	1.3	1.8	4695	0.86	0.88	5003	0.46	6000	
625.0	2.4	6674	1.7	1.6	7058	1.2	0.80	7756	0.65	6000	
712.7	2.1	6796	1.5	1.4	7186	1.1	0.70	7895	0.58	6000	
799.3	1.9	6406	1.3	1.3	6584	0.86	0.63	7016	0.46	6000	
929.1	1.6	4721	0.80	1.1	4848	0.55	0.54	5392	0.30	6000	
988.1	1.5	7109	1.1	1.0	7513	0.80	0.51	8249	0.44	6000	
1078	1.4	5479	0.80	0.93	5626	0.55	0.46	6258	0.30	6000	
1194	1.3	7053	0.93	0.84	7647	0.67	0.42	8460	0.37	6000	
1409	1.1	6924	0.77	0.71	7315	0.54	0.35	8028	0.30	6000	
1593	0.94	6678	0.66	0.63	7052	0.46	0.31	7734	0.25	6000	
1806	0.83	6763	0.59	0.55	7149	0.41	0.28	7948	0.23	6000	
1925	0.78	6850	0.56	0.52	7233	0.39	0.26	7929	0.22	6000	
2208	0.68	6978	0.50	0.45	7367	0.35	0.23	8074	0.19	6000	
2563	0.59	6470	0.40	0.39	6831	0.28	0.20	7488	0.15	6000	
2668	0.56	7157	0.42	0.37	7554	0.30	0.19	8277	0.16	6000	
3097	0.48	6636	0.34	0.32	7005	0.24	0.16	7677	0.13	6000	

Tutti i rapporti evidenziati (es. 10.50) hanno dimensioni particolari della coppia conica in certe versioni; vedere tavole dimensionali.

All ratios grey highlighted (ex. 10.50) have specific dimensions of the bevel gear set in some versions; see dimensional tables.

Alle mit (es. 10.50) gekennzeichneten Übersetzungen haben in bestimmten Versionen besondere Dimensionen des Kegelradtriebs. Siehe auch Dimensionstabellen.

Les rapports repérés par (es. 10.50) ont des dimensions de couple conique particulières. Voir les tableaux dimensionnels.

Todas las relaciones indicadas con (es. 10.50) tienen dimensiones particulares del par cónico según las versiones; ver las tablas de dimensión.

As relações marcadas com (es. 10.50) têm dimensões particulares da engrenagem cônica em certas versões; vide tabelas dimensionais.



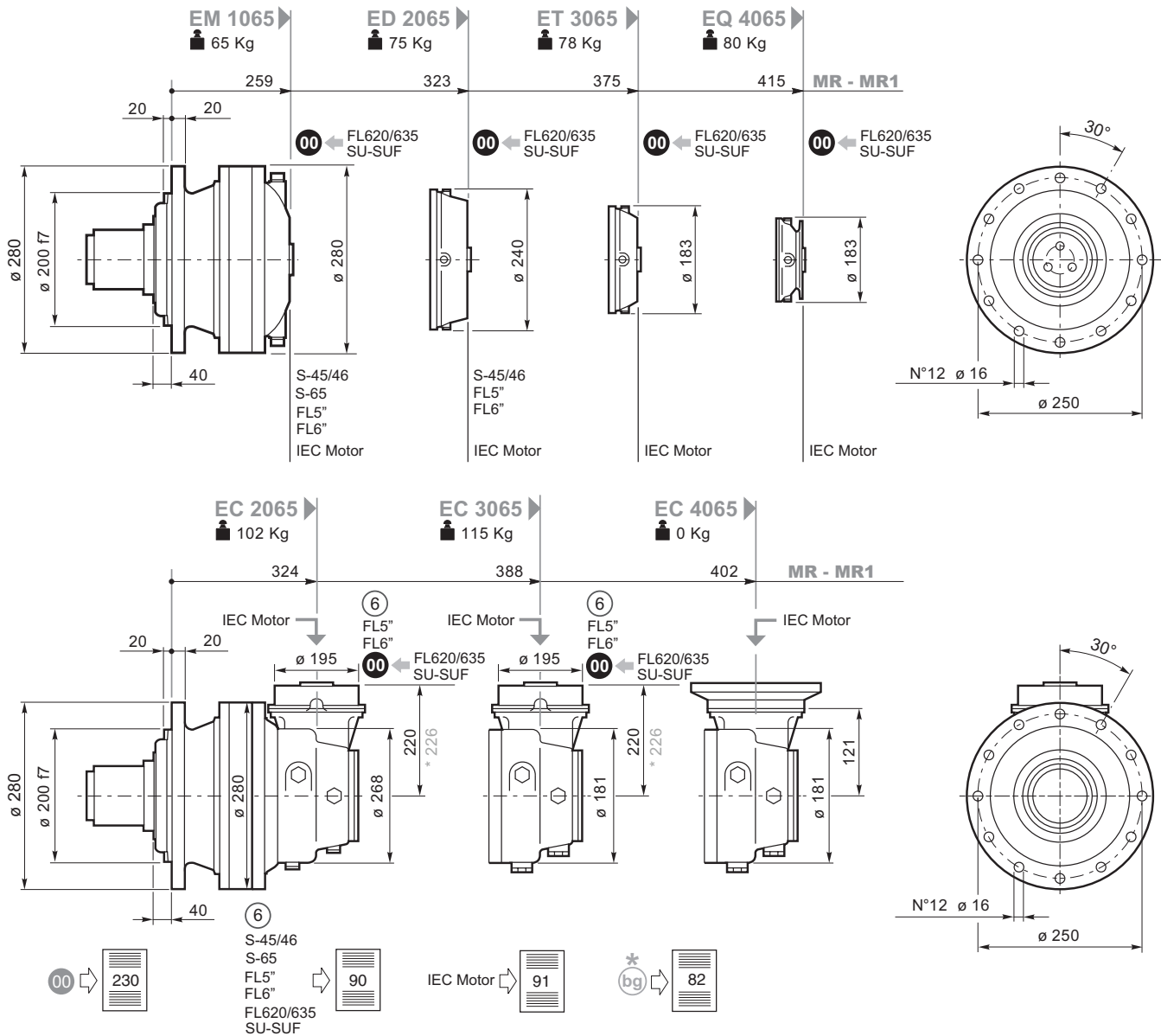
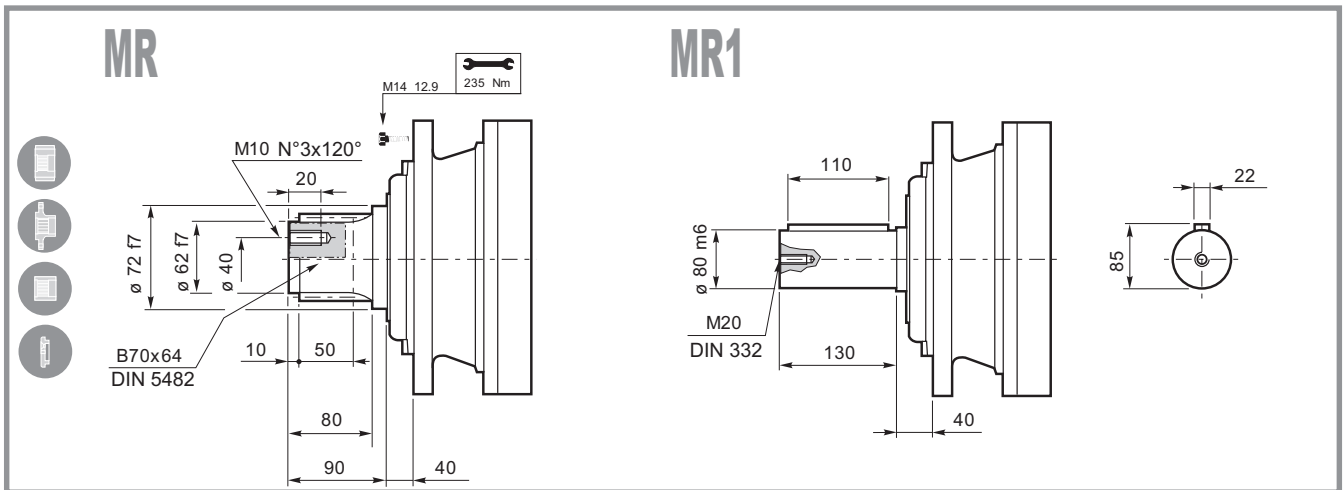



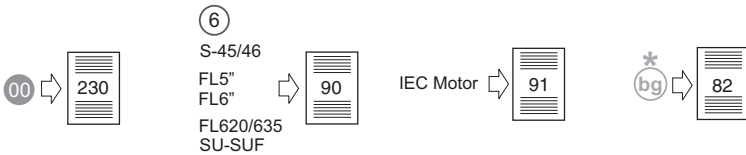
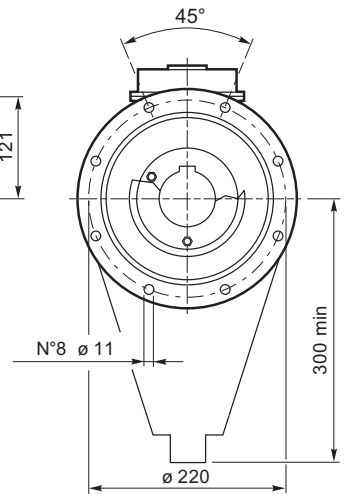
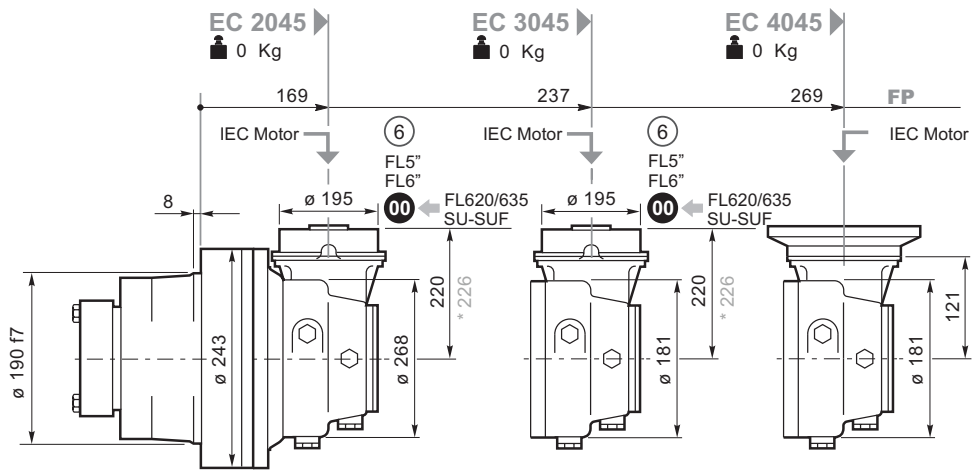
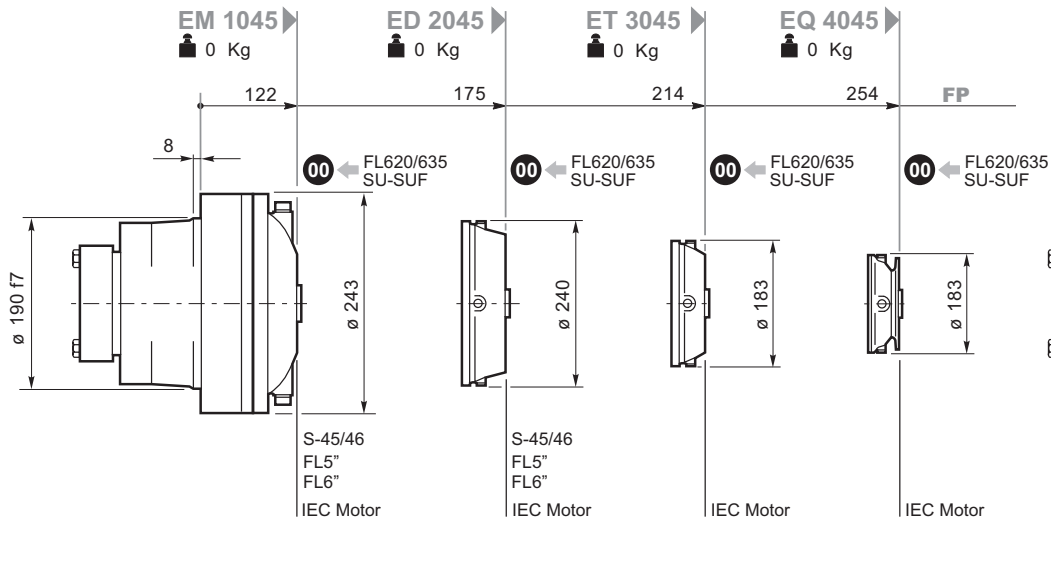
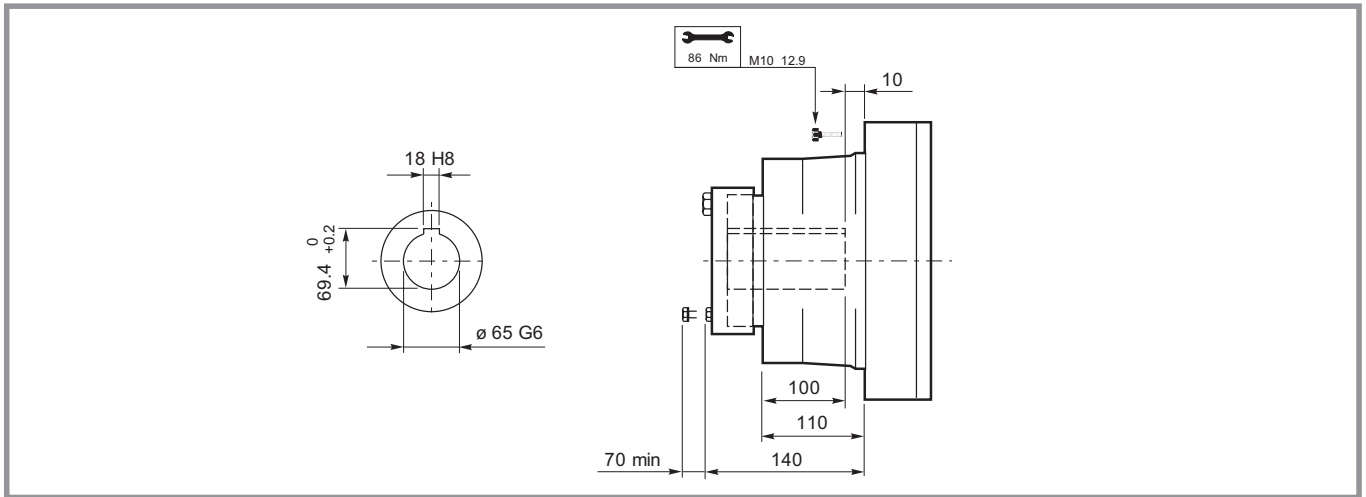

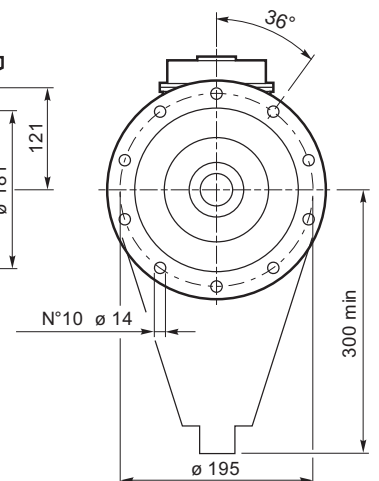
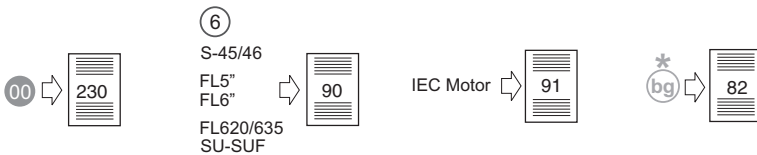
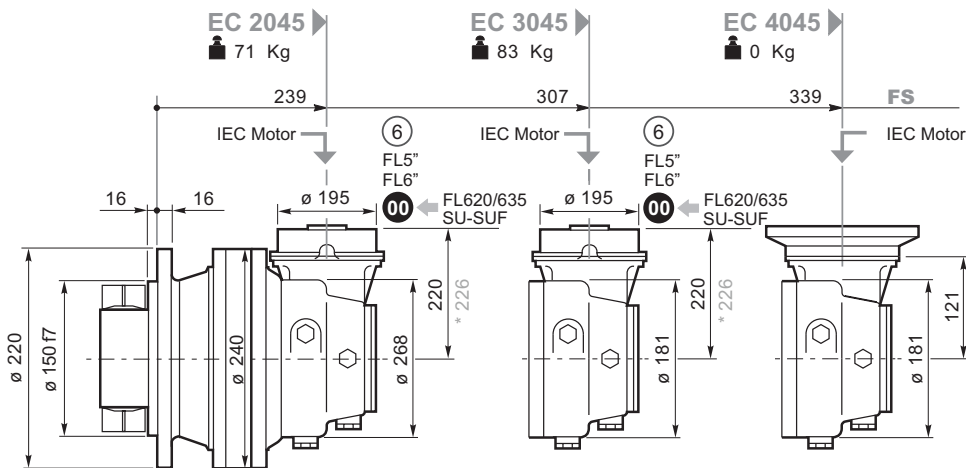
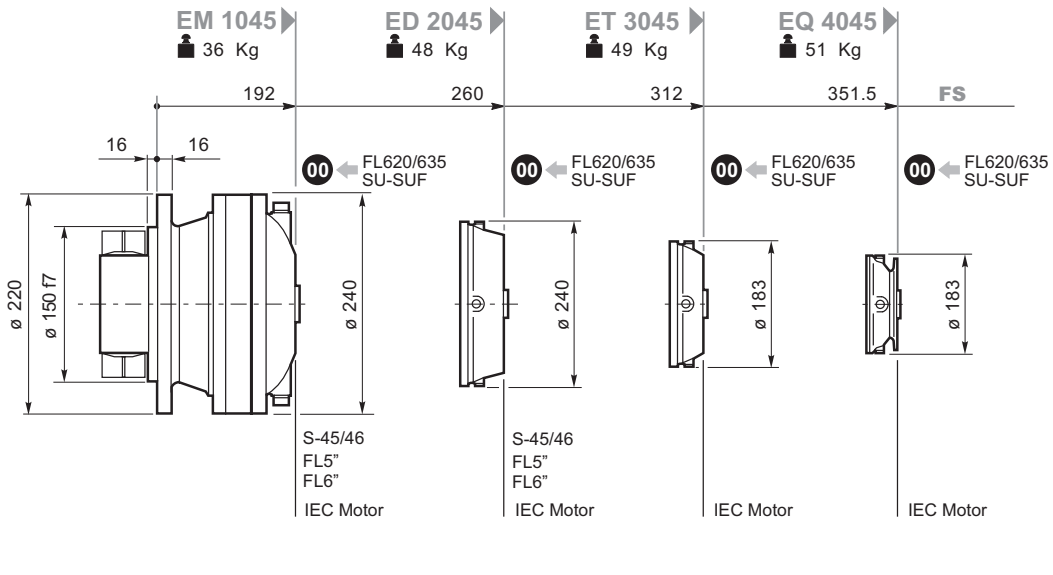
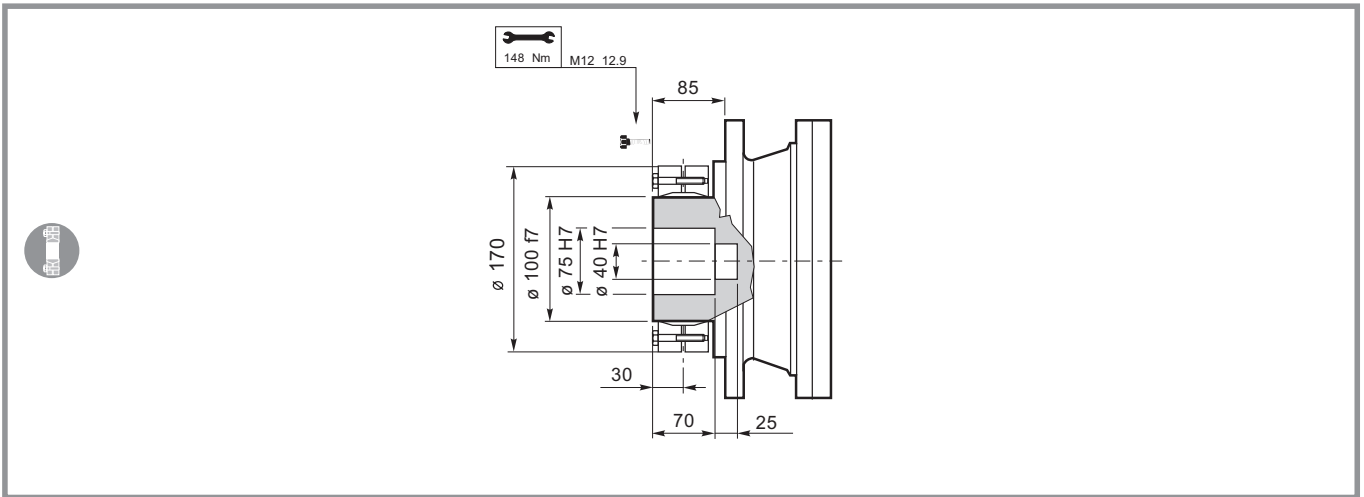

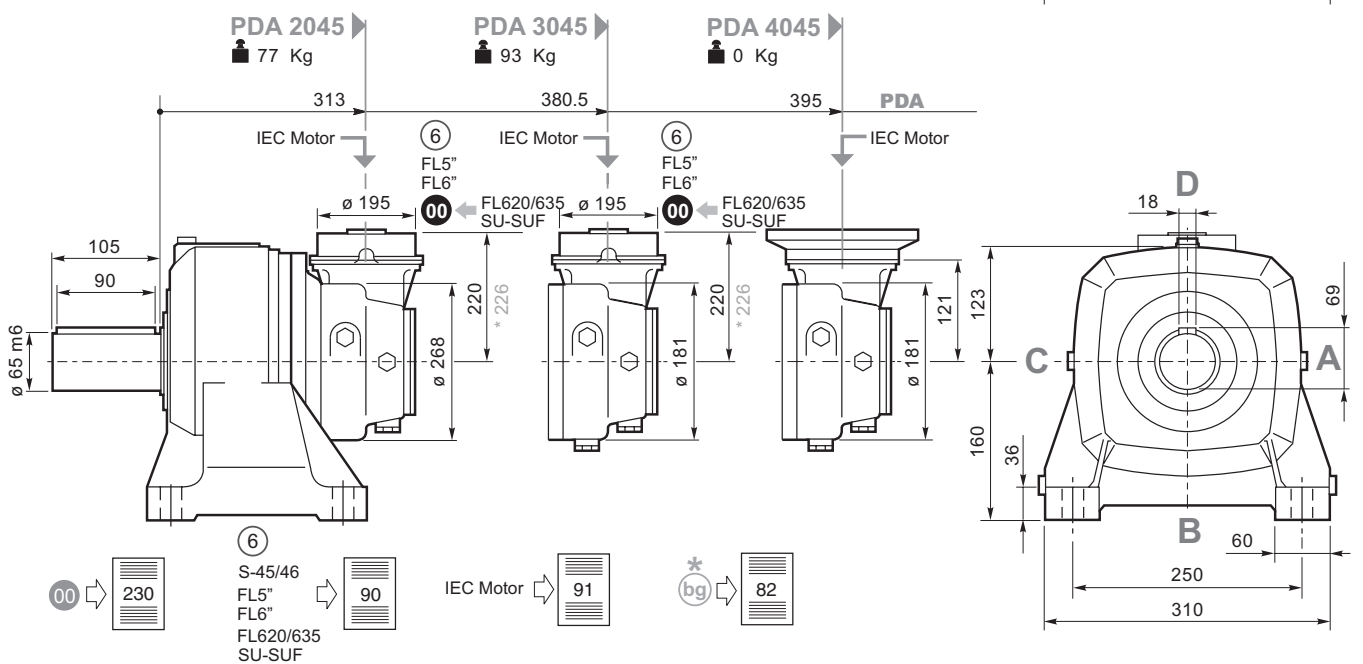
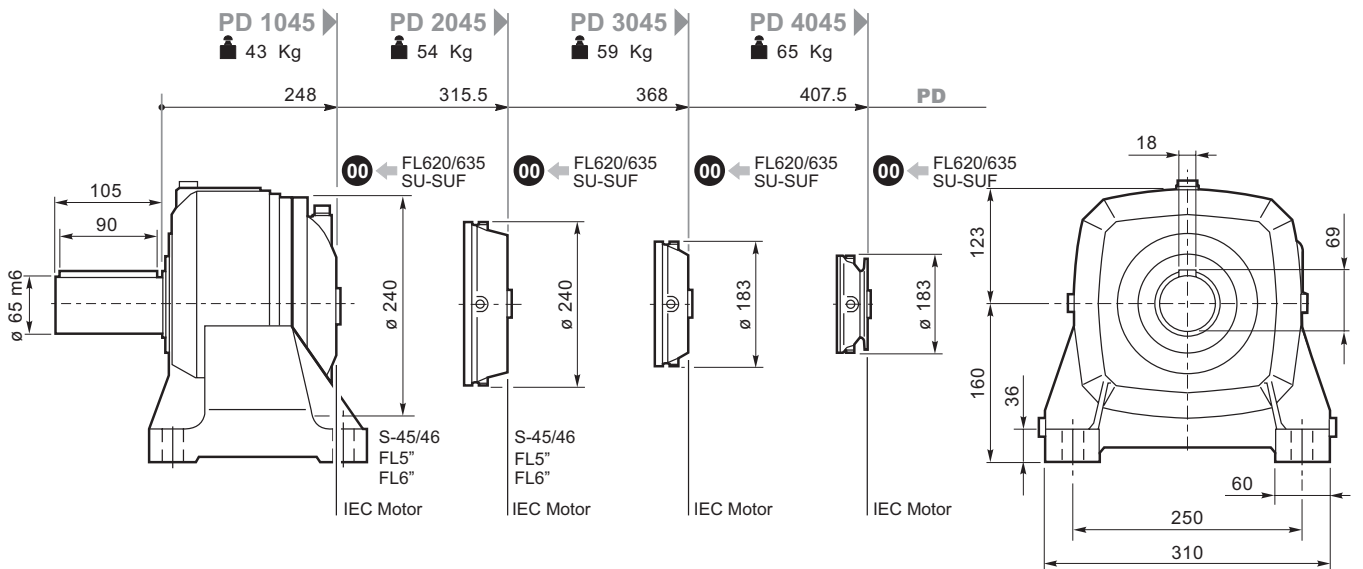
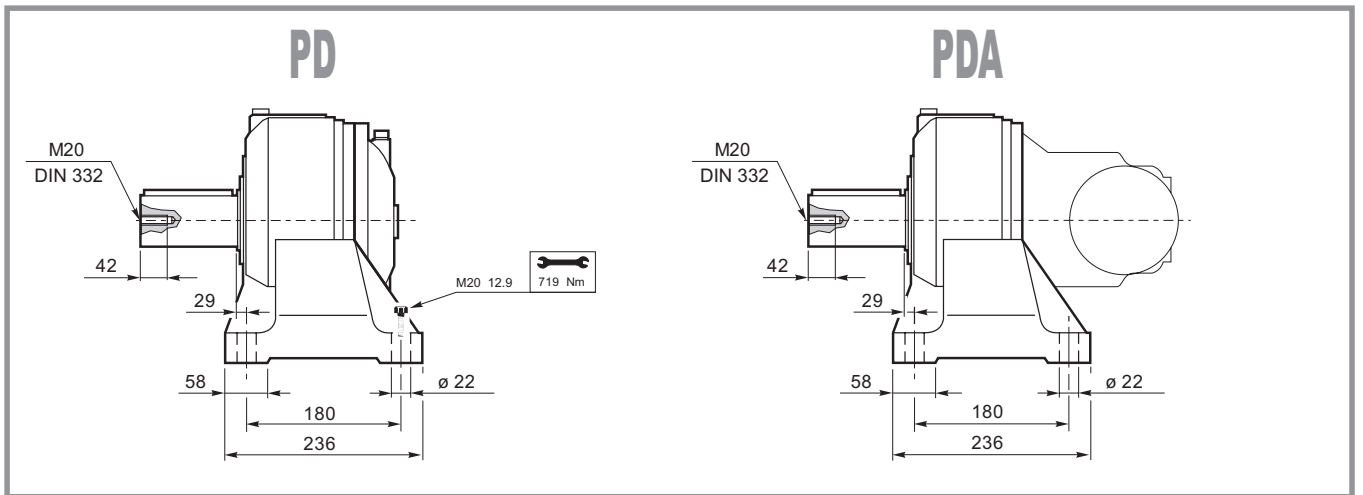





# 045

## S45CR1-S46C1

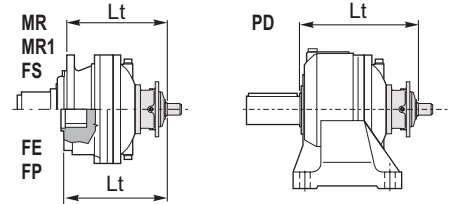
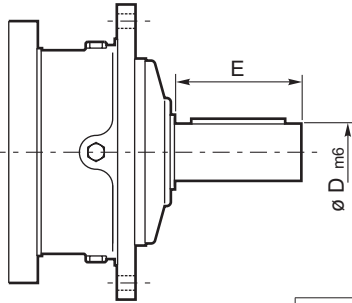

	D m6	E		Lt			
				MR-MR1-FS	FE	FP	PD
S45 CR1	65	58	EM 1045	255	211	185	311
			ED 2045	323	278	253	378.5
S46 C1	65	58	EM 1045	252	252	226	352
			ED 2045	364	319	294	419.5

## SU2

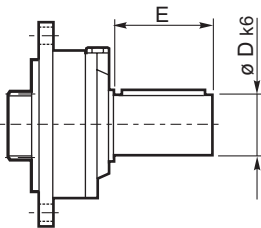

	D k6	E		Lt				
				MR MR1	FE	FS	FP	PD
SU 2	40	58	EM 1045	252	208	252	182	308
			ED 2045	320	275	320	250	375.5
			ET 3045	372	328	372	302	428
			EQ 4045	429	367	411.5	342	467.5

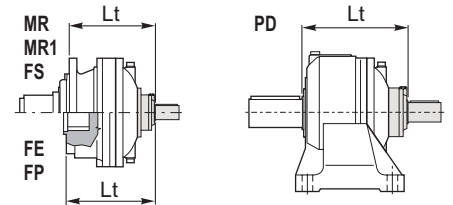

## ⑥ 48.82

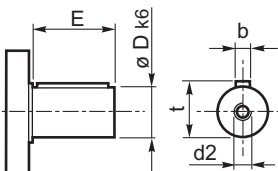

	D	E		Lt
				MR-MR1-FS-FE-FP-PDA
48.82	48	82	EC 2045	280
			EC 3045	280

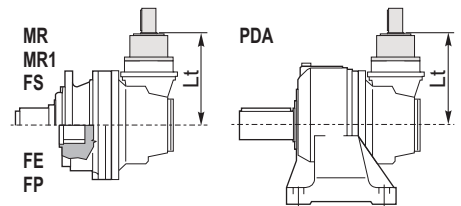

## FL250-FL350-FL450 FL750

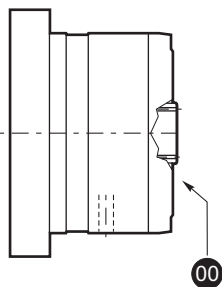

		Lt			
		MR-MR1-FS	FE	FP	PD
FL250 FL350 FL450	EM 1045	285	241	215	342
	ED 2045	353	309	283	410
	EC 2045	280	280	280	280
	EC 2045*	377	377	377	377
	EC 3045	280	280	280	280
	EC 3045*	377	377	377	377
FL750	EM 1045	297	254	228	355
	ED 2045	366	322	296	423

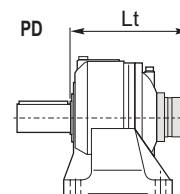
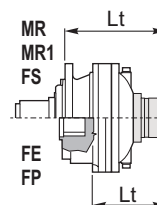

**FL620/10  
FL635/10**

**FL620U-FL635U**

SAE A-AA  
Shaft FE

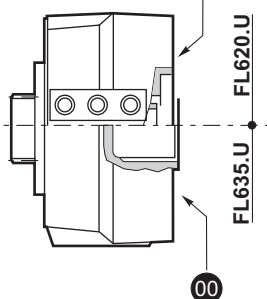

		Lt				
		MR-MR1-FS	FE	FP	PD	
FL620/U	EM 1045	296.5	252.5	226.5	352.5	
	ED 2045	364.5	319.5	294.5	420	
	ET 3045	416.5	372.5	346.5	472.5	
	EQ 4045	456.5	411.5	386.5	512	
	EC 2045	324.5	324.5	324.5	324.5	
	EC 2045*	330.5	330.5	330.5	330.5	
	EC 3045	324.5	324.5	324.5	324.5	
	EC 3045*	330.5	330.5	330.5	330.5	
	FL635U	EM 1045	283	329	213	339
		ED 2045	351	306	281	406.5
ET 3045		403	359	333	459	
EQ 4045		443	398	373	498.5	
EC 2045		311	311	311	311	
EC 2045*		317	317	317	317	
EC 3045		311	311	311	311	
EC 3045*		317	317	317	317	
FL620/10		ET 3045	376	332	306	432
		EQ 4045	416	371	346	492
FL635/10	ET 3045	357	313	287	413	
	EQ 4045	397	352	327	473	

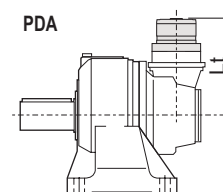
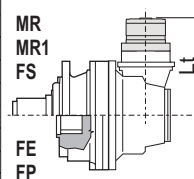

## IEC Motor

		Lt							
		IEC 63	IEC 71	IEC 80 90	IEC 100 112	IEC 132	IEC 160 180	IEC 200	IEC 225
EM 1045	MR-MR1-FS	212	214	219	220	287	318	328	359
EM1045	FE	168	170	175	176	243	274	284	315
EM1045	FP								
ED 2045	MR-MR1-FS	280	282	287	288	355	386	396	427
ED 2045	FE	235	237	242	243	310	341	351	382
ED 2045	FP								
ET 3045	MR-MR1-FS	332	334	339	340	407			
ET 3045	FE	288	290	295	296	363			
ET 3045	FP								
EQ 4045	MR-MR1-FS	372	374	379	380	447			
EQ 4045	FE	327	329	334	335	402			
EQ 4045	FP								
PD 1045	PD	268	270	275	276	343	374	384	415
PD 2045	PD	336	338	343	344	411	442	452	
PD 3045	PD	388	390	395	396	463			
PD 4045	PD	428	430	435	436	503			
EC 2045	MR-MR1-FE-FS-FP-PDA	240	242	247	248	315	346		
EC 2045*	MR-MR1-FE-FS-FP-PDA	246	248	253	254	321	352		
EC 3045	MR-MR1-FE-FS-FP-PDA	240	242	247	248	315	346		
EC 3045*	MR-MR1-FE-FS-FP-PDA	246	248	253	254	321	352		
EC 4045	MR-MR1-FE-FS-FP-PDA	151	151	151	151	238			

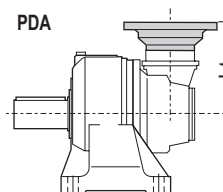
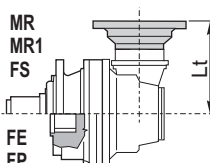
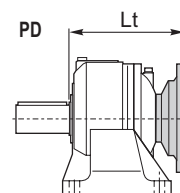
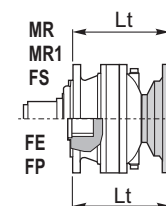

\* 82



**Flangia ruota**  
Driving flange  
Radnabenflansch  
Flasque de roue  
Brida de la rueda  
Flange de roda

**FA 045**

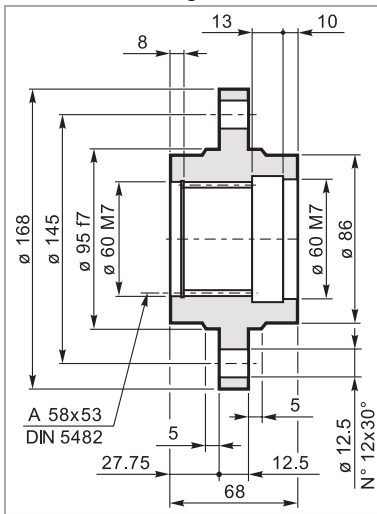

Mat. C40 UNI EN 10083  
Code: 34700641800



**Flangia ruota**  
Driving flange  
Radnabenflansch  
Flasque de roue  
Brida de la rueda  
Flange de roda

**FR 045**

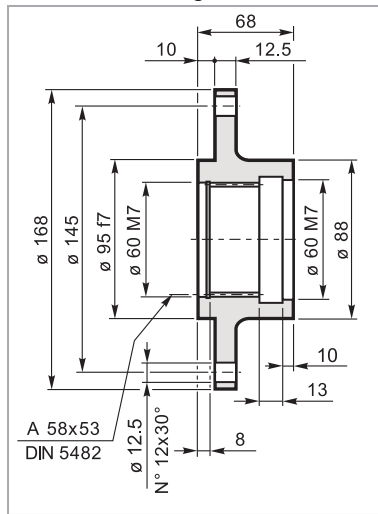

Mat. C40 UNI EN 10083  
Code: 34700131800



**Pignoni**  
Pinion  
Ritzel  
Pignon  
Piñones  
Pinhões

**IR 045**

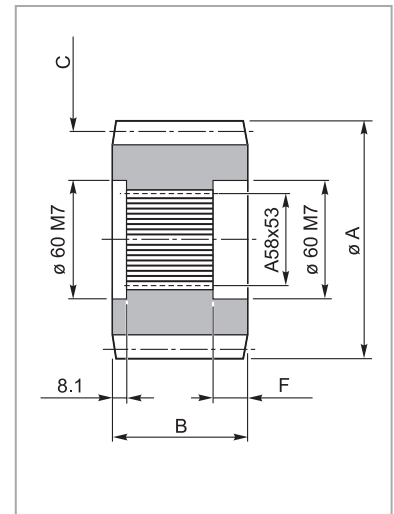

**Manicotto scanalato**  
Splined bush  
Keilmuffe  
Manchon cannelée  
Manguito acanalado  
Luva ranhurada

**MS 045**

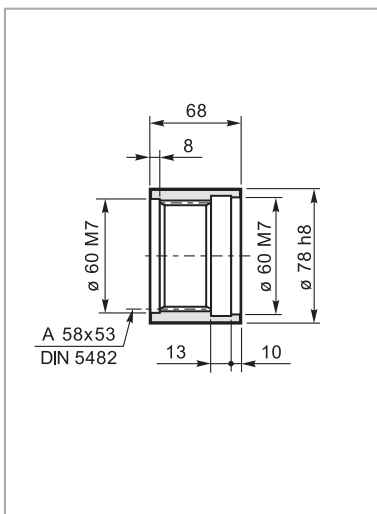

Mat. 39NiCrMo3 UNI EN 10083  
Code: 39102840600



**Rondella di fermo**  
Shaft cover  
Gegenseibe  
Rondelle frein  
Arandela de bloqueo  
Amuela de encosto

**RDF 045**

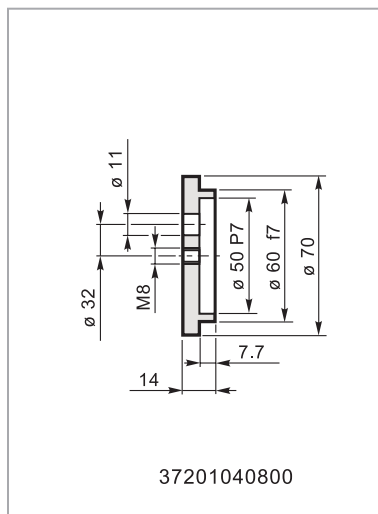

Mat. C40 UNI EN 10083  
Code:

code	A	B	C			F
335.0143.0800	114.8	68	M=8	Z=12	X=0.3	23.5
335.0174.0800	99.6	68	M=6	Z=14	X=0.3	24
335.0184.0800	114.8	80	M=8	Z=12	X=0.3	24
335.0274.0800	143	80	M=10	Z=12	X=0.35	23.5
335.0324.0800	136.2	80	M=8	Z=15	—	23.5
335.0344.0800	152	80	M=10	Z=13	X=0.3	23.5
335.0353.000K	127.6	68	M=8	Z=13	X=0.54	23.5
335.2133.0600	143.4	80	M=8	Z=15	X=0.4	23.5
335.3473.0600	156	80	M=6	Z=24	—	23
335.4273.0600	142	80	M=8	Z=16	—	23.5
335.5193.060	115	68	M=5	Z=21	—	24
335.5942.000	136	80	M=8	Z=14	X=0.4	23.5
335.6273.000	120	68	M=8	Z=13	—	24



**Barra scanalata**  
Splined bar  
Zugspindel  
Barre cannelée  
Barra acanalada  
Barra ranhurada

**BS 045**

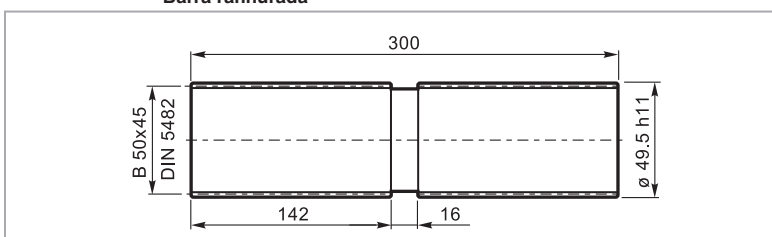

Mat. 39NiCrMo3 UNI EN 10083  
Code: 39126930100

Carichi radiali sugli alberi uscita / Radial loads on output shafts  
 Radiallasten auf de Abtriebswellen / Charges radiales sur les arbres de sortie  
 Cargas sobre los ejes de salida / Cargas radiais nos eixos de saída

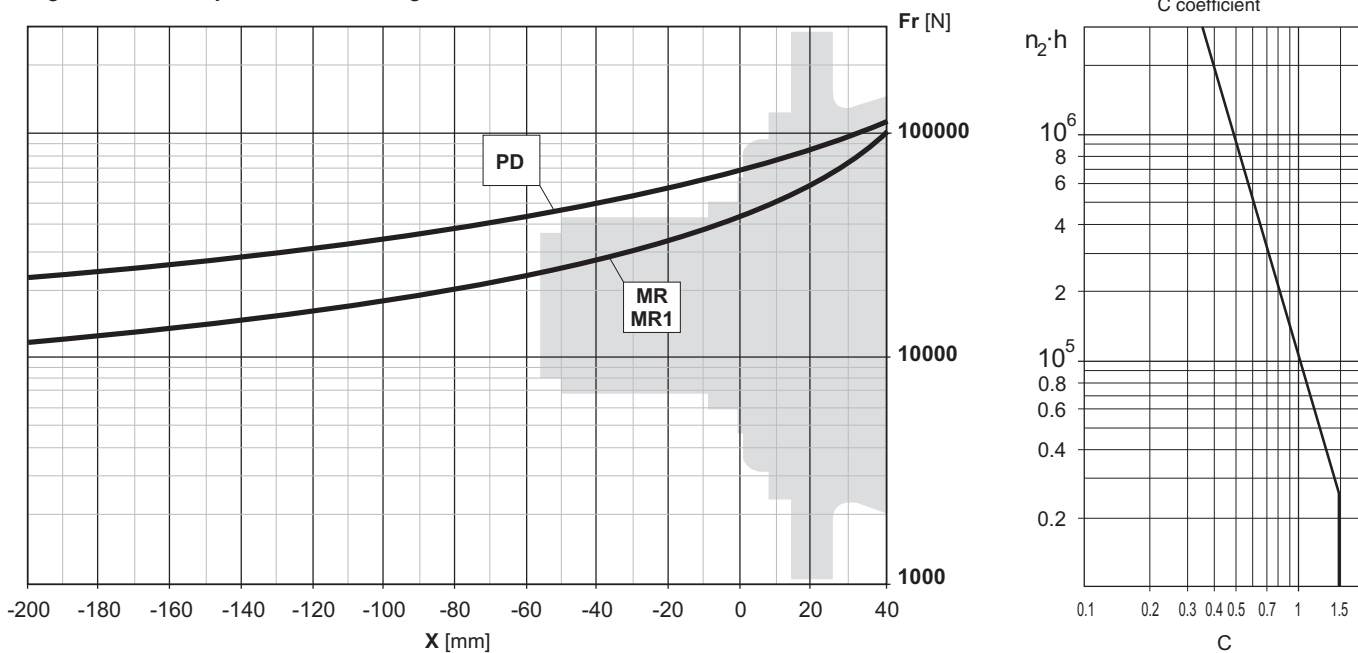

Carichi assiali / Axial loads / Axialkräfte / Charges axiales / Cargas axiales / Forças axiais

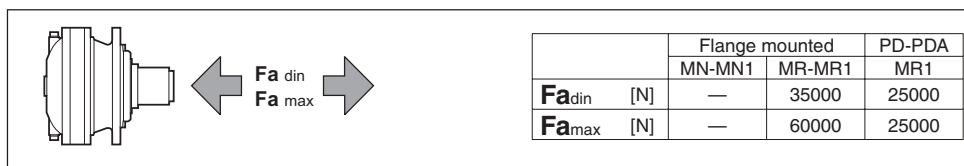

Carichi radiali sugli alberi entrata / Radial loads on input shafts  
 Radiallasten auf de Antriebswellen / Charges radiales sur les arbres d'entrée  
 Cargas sobre los ejes de entrada / Cargas radiais nos eixos de entrada

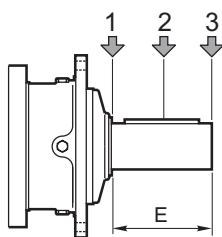

Type	E	$Fr$ [N]					
		$n_1 \cdot h = 10^7$			$n_1 \cdot h = 10^8$		
		1	2	3	1	2	3
S45 CR1	105	10000	6000	4000	5000	3000	2000
S46 C1	105	104000	8800	6400	7000	4400	3200

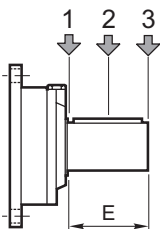

Type	E	$Fr$ [N]					
		$n_1 \cdot h = 10^7$			$n_1 \cdot h = 10^8$		
		1	2	3	1	2	3
SU2	58	3000	2000	1500	1400	1000	700

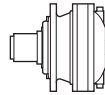

$i_{eff}$	1500			1000			500			$T_{2max}$ [Nm]	$P_T$ [kW]
	$n_2$ [rpm]	$T_2$ [Nm]	$P_2$ [kW]	$n_2$ [rpm]	$T_2$ [Nm]	$P_2$ [kW]	$n_2$ [rpm]	$T_2$ [Nm]	$P_2$ [kW]		
<b>EM 1046</b>											
3.50	429	1565	70	286	1767	53	143	2175	32.6	6000	20
4.13	363	1617	62	242	1827	46.3	121	2249	28.5	6000	
5.17	290	1682	51	193	1900	38.5	97	2339	23.7	6000	
6.00	250	1732	45.4	167	1956	34.1	83	2173	19.0	6000	
7.25	207	1582	34.3	138	1695	24.5	69	1868	13.5	6000	
<b>ED 2046</b>											
10.78	139	2193	32.0	93	2476	24.1	46.4	3049	14.8	6000	15
12.25	122	2278	29.2	82	2573	22.0	40.8	3168	13.5	6000	
14.46	104	2394	26.0	69	2704	19.6	34.6	3329	12.1	6000	
17.06	88	2475	22.8	59	2795	17.2	29.3	3393	10.4	6000	
18.10	83	2561	22.2	55	2893	16.7	27.6	3562	10.3	6000	
21.00	71	2678	20.0	47.6	3025	15.1	23.8	3724	9.3	6000	
25.38	59	2835	17.6	39.4	3202	13.2	19.7	3553	7.3	6000	
29.94	50	2931	15.4	33.4	3310	11.6	16.7	3583	6.3	6000	
31.02	48.4	2582	13.1	32.2	2698	9.1	16.1	2893	4.9	6000	
36.00	41.7	2358	10.3	27.8	2463	7.2	13.9	2640	3.8	6000	
43.50	34.5	2407	8.7	23.0	2511	6.0	11.5	2689	3.2	6000	
52.56	28.5	2070	6.2	19.0	2161	4.3	9.5	2319	2.3	6000	
<b>ET 3046</b>											
53.78	27.9	3552	10.4	18.6	3961	7.7	9.3	4314	4.2	6000	10
63.46	23.6	3732	9.2	15.8	4022	6.6	7.9	4469	3.7	6000	
73.50	20.4	3901	8.3	13.6	4077	5.8	6.8	4609	3.3	6000	
79.44	18.9	3955	7.8	12.6	4106	5.4	6.3	4684	3.1	6000	
92.19	16.3	4010	6.8	10.8	4174	4.7	5.4	4831	2.7	6000	
100.3	15.0	4042	6.3	10.0	4250	4.4	5.0	4915	2.6	6000	
108.6	13.8	4071	5.9	9.2	4323	4.2	4.6	4996	2.4	6000	
125.6	11.9	4125	5.2	8.0	4459	3.7	4.0	5146	2.1	6000	
145.7	10.3	4221	4.6	6.9	4601	3.3	3.4	5088	1.8	6000	
152.3	9.9	3846	4.0	6.6	4014	2.8	3.3	4302	1.5	6000	
176.1	8.5	3907	3.5	5.7	4074	2.4	2.8	4363	1.3	6000	
207.8	7.2	3970	3.0	4.8	4326	2.2	2.4	4941	1.2	6000	
224.2	6.7	4035	2.8	4.5	4395	2.1	2.2	4798	1.1	6000	
260.2	5.8	4165	2.5	3.8	4532	1.8	1.9	4970	1.0	6000	
280.7	5.3	3302	1.8	3.6	3605	1.3	1.8	4167	0.78	6000	
314.4	4.8	4334	2.2	3.2	4711	1.6	1.6	5022	0.84	6000	
364.8	4.1	2542	1.1	2.7	2788	0.80	1.4	3244	0.47	6000	
<b>EQ 4046</b>											
404.7	3.7	5051	2.0	2.5	5245	1.4	1.2	5615	0.73	6000	6
441.0	3.4	5312	1.9	2.3	5418	1.3	1.1	5684	0.68	6000	
510.1	2.9	5382	1.7	2.0	5439	1.1	0.98	5803	0.60	6000	
551.3	2.7	5393	1.5	1.8	5449	1.0	0.91	5867	0.56	6000	
639.8	2.3	5270	1.3	1.6	5470	0.90	0.78	5992	0.49	6000	
696.2	2.2	5425	1.2	1.4	5495	0.83	0.72	6064	0.46	6000	
773.1	1.9	4524	0.92	1.3	4698	0.64	0.65	5463	0.37	6000	
913.5	1.6	4595	0.79	1.1	4866	0.56	0.55	5662	0.33	6000	
1011	1.5	5477	0.85	0.99	5796	0.60	0.49	6389	0.33	6000	
1140	1.3	5565	0.77	0.88	5895	0.54	0.44	6496	0.30	6000	
1222	1.2	4743	0.61	0.82	5190	0.45	0.41	6021	0.26	6000	
1442	1.0	5337	0.58	0.69	5652	0.41	0.35	6226	0.23	6000	
1599	0.94	5036	0.50	0.63	5502	0.36	0.31	6366	0.21	6000	
1849	0.81	5200	0.44	0.54	5676	0.32	0.27	6559	0.19	6000	
1995	0.75	4415	0.35	0.50	4530	0.24	0.25	4730	0.12	6000	
2315	0.65	5124	0.35	0.43	5257	0.24	0.22	5489	0.12	6000	
2623	0.57	4633	0.28	0.38	5013	0.20	0.19	5720	0.11	6000	
2798	0.54	5687	0.32	0.36	6193	0.23	0.18	6633	0.12	6000	
3301	0.45	5997	0.29	0.30	6343	0.20	0.15	6975	0.11	6000	

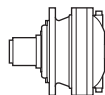

$i_{eff}$	1500			1000			500			$T_{2max}$ [Nm]	$P_T$ [kW]
	$n_2$ [rpm]	$T_2$ [Nm]	$P_2$ [kW]	$n_2$ [rpm]	$T_2$ [Nm]	$P_2$ [kW]	$n_2$ [rpm]	$T_2$ [Nm]	$P_2$ [kW]		
<b>EM 1046</b>											
3.50	429	2764	124	286	3122	93	143	3773	56	6000	20
4.13	363	2858	109	242	3112	79	121	3449	43.7	6000	
5.17	290	2411	73	193	2592	53	97	2855	28.9	6000	
6.00	250	2238	59	167	2391	41.7	83	2618	22.8	6000	
7.25	207	1953	42.3	138	2077	30.0	69	2267	16.4	6000	
<b>ED 2046</b>											
10.78	139	3786	55	93	3980	38.7	46.4	4542	22.1	6000	15
12.25	122	3849	49.4	82	4038	34.5	40.8	4671	20.0	6000	
14.46	104	3928	42.7	69	4147	30.0	34.6	4841	17.5	6000	
17.06	88	3585	33.0	59	3753	23.0	29.3	4381	13.5	6000	
18.10	83	4031	35.0	55	4368	25.3	27.6	5077	14.7	6000	
21.00	71	4116	30.8	47.6	4516	22.5	23.8	4974	12.4	6000	
25.38	59	3705	22.9	39.4	3933	16.2	19.7	4283	8.8	6000	
29.94	50	3892	20.4	33.4	4260	14.9	16.7	4921	8.6	6000	
31.02	48.4	3085	15.6	32.2	3352	11.3	16.1	3901	6.6	6000	
36.00	41.7	2823	12.3	27.8	3053	8.9	13.9	3555	5.2	6000	
43.50	34.5	2905	10.5	23.0	3186	7.7	11.5	3700	4.5	6000	
52.56	28.5	2504	7.5	19.0	2753	5.5	9.5	3211	3.2	6000	
<b>ET 3046</b>											
53.78	27.9	5067	14.8	18.6	5371	10.5	9.3	5509	5.4	6000	10
63.46	23.6	5244	13.0	15.8	5397	8.9	7.9	5643	4.7	6000	
73.50	20.4	5356	11.4	13.6	5419	7.7	6.8	5763	4.1	6000	
79.44	18.9	5369	10.6	12.6	5431	7.2	6.3	5828	3.8	6000	
92.19	16.3	5186	8.8	10.8	5404	6.1	5.4	5953	3.4	6000	
100.3	15.0	5405	8.5	10.0	5466	5.7	5.0	6024	3.1	6000	
108.6	13.8	5417	7.8	9.2	5517	5.3	4.6	6092	2.9	6000	
125.6	11.9	5439	6.8	8.0	5634	4.7	4.0	6218	2.6	6000	
145.7	10.3	5452	5.9	6.9	5756	4.1	3.4	6350	2.3	6000	
152.3	9.9	4609	4.8	6.6	4961	3.4	3.3	5779	2.0	6000	
176.1	8.5	4677	4.2	5.7	5127	3.0	2.8	5961	1.8	6000	
207.8	7.2	5299	4.0	4.8	5616	2.8	2.4	6189	1.6	6000	
224.2	6.7	4963	3.5	4.5	5127	2.4	2.2	5390	1.3	6000	
260.2	5.8	5473	3.3	3.8	5797	2.3	1.9	6256	1.3	6000	
280.7	5.3	4887	2.7	3.6	5290	2.0	1.8	6039	1.1	6000	
314.4	4.8	5622	2.8	3.2	5953	2.0	1.6	6554	1.1	6000	
364.8	4.1	3829	1.6	2.7	4156	1.2	1.4	4763	0.68	6000	
<b>EQ 4046</b>											
404.7	3.7	6281	2.4	2.5	6647	1.7	1.2	7312	0.95	6000	6
441.0	3.4	6357	2.3	2.3	6727	1.6	1.1	7398	0.88	6000	
510.1	2.9	6488	2.0	2.0	6863	1.4	0.98	7546	0.78	6000	
551.3	2.7	6559	1.9	1.8	6937	1.3	0.91	7626	0.72	6000	
639.8	2.3	6696	1.6	1.6	7080	1.2	0.78	7781	0.64	6000	
696.2	2.2	6774	1.5	1.4	7163	1.1	0.72	7870	0.59	6000	
773.1	1.9	6455	1.3	1.3	7012	0.95	0.65	7982	0.54	6000	
913.5	1.6	6680	1.1	1.1	7251	0.83	0.55	8163	0.47	6000	
1011	1.5	7132	1.1	0.99	7537	0.78	0.49	8275	0.43	6000	
1140	1.3	7249	1.0	0.88	7660	0.70	0.44	8408	0.39	6000	
1222	1.2	7086	0.91	0.82	7682	0.66	0.41	8487	0.36	6000	
1442	1.0	6946	0.76	0.69	7338	0.53	0.35	8053	0.29	6000	
1599	0.94	7477	0.74	0.63	8018	0.53	0.31	8795	0.29	6000	
1849	0.81	7695	0.65	0.54	8176	0.46	0.27	8966	0.25	6000	
1995	0.75	5123	0.40	0.50	5451	0.29	0.25	6058	0.16	6000	
2315	0.65	5945	0.40	0.43	6326	0.29	0.22	7031	0.16	6000	
2623	0.57	6490	0.39	0.38	6852	0.27	0.19	7511	0.15	6000	
2798	0.54	7184	0.40	0.36	7644	0.29	0.18	8495	0.16	6000	
3301	0.45	7767	0.37	0.30	8199	0.26	0.15	8984	0.14	6000	

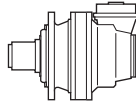

$i_{eff}$	1500			1000			500			$T_{2max}$ [Nm]	$P_T$ [kW]
	$n_2$ [rpm]	$T_2$ [Nm]	$P_2$ [kW]	$n_2$ [rpm]	$T_2$ [Nm]	$P_2$ [kW]	$n_2$ [rpm]	$T_2$ [Nm]	$P_2$ [kW]		

**EC 2046 - PDA 2046**

10.50	143	2175	32.6	95	2457	24.5	47.6	3025	15.1	6000	
12.39	121	2249	28.5	81	2540	21.5	40.4	3127	13.2	6000	
16.17	93	1582	15.4	62	1787	11.6	30.9	2200	7.1	6000	
18.00	83	2173	19.0	56	2283	13.3	27.8	2463	7.2	6000	
19.08	79	1867	15.4	52	2109	11.6	26.2	2596	7.1	6000	12
21.75	69	1868	13.5	46.0	1962	9.4	23.0	2119	5.1	6000	
23.89	63	2337	15.4	41.9	2624	11.5	20.9	2820	6.2	6000	
27.72	54	2290	13.0	36.1	2396	9.1	18.0	2573	4.9	6000	
33.50	44.8	1968	9.2	29.9	2060	6.4	14.9	2216	3.5	6000	

**EC 3046 - PDA 3046**

36.75	40.8	3168	13.5	27.2	3578	10.2	13.6	4077	5.8	6000	
43.37	34.6	3329	12.1	23.1	3760	9.1	11.5	4138	5.0	6000	
49.80	30.1	3471	10.9	20.1	3920	8.2	10.0	4244	4.5	6000	
56.60	26.5	3606	10.0	17.7	3980	7.4	8.8	4362	4.0	6000	
63.00	23.8	3724	9.3	15.9	4020	6.7	7.9	4462	3.7	6000	
73.57	20.4	2827	6.0	13.6	2941	4.2	6.8	3139	2.2	6000	
83.60	17.9	3974	7.5	12.0	4125	5.2	6.0	4734	3.0	6000	
89.83	16.7	3583	6.3	11.1	3719	4.3	5.6	4196	2.4	6000	7
97.02	15.5	4029	6.5	10.3	4220	4.6	5.2	4882	2.6	6000	
114.5	13.1	3664	5.0	8.7	3810	3.5	4.4	4414	2.0	600c	
123.5	12.1	2973	3.8	8.1	3088	2.6	4.0	3508	1.5	6000	
138.3	10.8	3728	4.2	7.2	3969	3.0	3.6	4590	1.7	6000	
166.3	9.0	2752	2.6	6.0	2858	1.8	3.0	3296	1.0	6000	
173.2	8.7	3069	2.8	5.8	3246	2.0	2.9	3770	1.1	6000	
201.0	7.5	2801	2.2	5.0	2951	1.5	2.5	3432	0.89	6000	
242.8	6.2	2419	1.6	4.1	2541	1.1	2.1	2970	0.64	6000	

**EC 4046 - PDA 4046**

276.6	5.4	4831	2.7	3.6	5063	1.9	1.8	5396	1.0	6000	
310.3	4.8	4946	2.5	3.2	5369	1.8	1.6	5466	0.92	6000	
347.1	4.3	4978	2.3	2.9	5171	1.6	1.4	5493	0.83	6000	
414.7	3.6	5246	2.0	2.4	5410	1.4	1.2	5635	0.71	6000	
450.8	3.3	5103	1.8	2.2	5297	1.2	1.1	5702	0.66	6000	
498.3	3.0	5379	1.7	2.0	5435	1.1	1.0	5784	0.61	6000	
570.0	2.6	4066	1.1	1.8	4179	0.77	0.88	4372	0.40	6000	
625.0	2.4	5259	1.3	1.6	5456	0.91	0.80	5972	0.50	6000	
712.7	2.1	5322	1.2	1.4	5514	0.81	0.70	6084	0.45	6000	
799.3	1.9	4538	0.89	1.3	4722	0.62	0.63	5502	0.36	6000	
929.1	1.6	4202	0.71	1.1	4315	0.49	0.54	4509	0.25	6000	
988.1	1.5	5474	0.87	1.0	5777	0.61	0.51	6368	0.34	6000	3
1078	1.4	4877	0.71	0.93	5008	0.49	0.46	5233	0.25	6000	
1194	1.3	4718	0.62	0.84	5164	0.45	0.42	5991	0.26	6000	
1409	1.1	5319	0.59	0.71	5633	0.42	0.35	6206	0.23	6000	
1593	0.94	4738	0.47	0.63	5130	0.34	0.31	5859	0.19	6000	
1806	0.83	5174	0.45	0.55	5648	0.33	0.28	6455	0.19	6000	
1925	0.78	4918	0.40	0.52	5322	0.29	0.26	6072	0.17	6000	
2208	0.68	5052	0.36	0.45	5465	0.26	0.23	6231	0.15	6000	
2563	0.59	4611	0.28	0.39	4990	0.20	0.20	5695	0.12	6000	
2668	0.56	5242	0.31	0.37	5666	0.22	0.19	6428	0.13	6000	
3097	0.48	4785	0.24	0.32	5176	0.18	0.16	5900	0.10	6000	

Tutti i rapporti evidenziati (es. 10.50) hanno dimensioni particolari della coppia conica in certe versioni; vedere tavole dimensionali.

All ratios grey highlighted (ex. 10.50) have specific dimensions of the bevel gear set in some versions; see dimensional tables.

Alle mit (es. 10.50) gekennzeichneten Übersetzungen haben in bestimmten Versionen besondere Dimensionen des Kegelradtriebs. Siehe auch Dimensionstabellen.

Les rapports repérés par (es. 10.50) ont des dimensions de couple conique particulières. Voir les tableaux dimensionnels.

Todas las relaciones indicadas con (es. 10.50) tienen dimensiones particulares del par cónico según las versiones; ver las tablas de dimensión.

As relações marcadas com (es. 10.50) têm dimensões particulares da engrenagem cônica em certas versões; vide tabelas dimensionais.



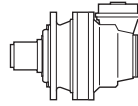

$i_{eff}$	1500			1000			500			$T_{2max}$ [Nm]	$P_T$ [kW]
	$n_2$ [rpm]	$T_2$ [Nm]	$P_2$ [kW]	$n_2$ [rpm]	$T_2$ [Nm]	$P_2$ [kW]	$n_2$ [rpm]	$T_2$ [Nm]	$P_2$ [kW]		

**EC 2046 - PDA 2046**

10.50	143	3773	56	95	3968	39.6	47.6	4516	22.5	6000	
12.39	121	3449	43.7	81	3620	30.6	40.4	4086	17.3	6000	
16.17	93	2796	27.2	62	3157	20.5	30.9	3887	12.6	6000	
18.00	83	2618	22.8	56	2739	15.9	27.8	3053	8.9	6000	
19.08	79	3299	27.2	52	3726	20.5	26.2	4488	12.3	6000	12
21.75	69	2267	16.4	46.0	2371	11.4	23.0	2636	6.3	6000	
23.89	63	3001	19.7	41.9	3156	13.8	20.9	3688	8.1	6000	
27.72	54	2747	15.6	36.1	2875	10.9	18.0	3360	6.3	6000	
33.50	44.8	2378	11.2	29.9	2480	7.8	14.9	2908	4.5	6000	

**EC 3046 - PDA 3046**

36.75	40.8	4671	20.0	27.2	5093	14.5	13.6	5419	7.7	6000	
43.37	34.6	4841	17.5	23.1	5271	12.7	11.5	5444	6.6	6000	
49.80	30.1	4986	15.7	20.1	5359	11.3	10.0	5465	5.7	6000	
56.60	26.5	5121	14.2	17.7	5379	10.0	8.8	5550	5.1	6000	
63.00	23.8	4974	12.4	15.9	5200	8.6	7.9	5637	4.7	6000	
73.57	20.4	3709	7.9	13.6	4043	5.8	6.8	4659	3.3	6000	
83.60	17.9	5377	10.1	12.0	5439	6.8	6.0	5870	3.7	6000	
89.83	16.7	4921	8.6	11.1	4977	5.8	5.6	5500	3.2	6000	7
97.02	15.5	5214	8.4	10.3	5450	5.9	5.2	5996	3.2	6000	
114.5	13.1	4955	6.8	8.7	5155	4.7	4.4	5693	2.6	6000	
123.5	12.1	4139	5.3	8.1	4497	3.8	4.0	5161	2.2	6000	
138.3	10.8	4995	5.7	7.2	5298	4.0	3.6	5847	2.2	6000	
166.3	9.0	3892	3.7	6.0	4228	2.7	3.0	4851	1.5	6000	
173.2	8.7	4437	4.0	5.8	4813	2.9	2.9	5509	1.7	6000	
201.0	7.5	4046	3.2	5.0	4392	2.3	2.5	5032	1.3	6000	
242.8	6.2	3520	2.3	4.1	3828	1.7	2.1	4399	0.95	6000	

**EC 4046 - PDA 4046**

276.6	5.4	5953	3.4	3.6	6303	2.4	1.8	6940	1.3	6000	
310.3	4.8	6050	3.1	3.2	6406	2.2	1.6	7051	1.2	6000	
347.1	4.3	6147	2.8	2.9	6507	2.0	1.4	7160	1.1	6000	
414.7	3.6	6303	2.4	2.4	6669	1.7	1.2	7336	0.93	6000	
450.8	3.3	6377	2.2	2.2	6747	1.6	1.1	7420	0.86	6000	
498.3	3.0	6467	2.0	2.0	6841	1.4	1.0	7522	0.79	6000	
570.0	2.6	4568	1.3	1.8	4695	0.86	0.88	5003	0.46	6000	
625.0	2.4	6674	1.7	1.6	7058	1.2	0.80	7756	0.65	6000	
712.7	2.1	6796	1.5	1.4	7186	1.1	0.70	7895	0.58	6000	
799.3	1.9	6406	1.3	1.3	6584	0.86	0.63	7016	0.46	6000	
929.1	1.6	4721	0.80	1.1	4848	0.55	0.54	5392	0.30	6000	
988.1	1.5	7109	1.1	1.0	7513	0.80	0.51	8249	0.44	6000	
1078	1.4	5479	0.80	0.93	5626	0.55	0.46	6258	0.30	6000	
1194	1.3	7053	0.93	0.84	7647	0.67	0.42	8460	0.37	6000	
1409	1.1	6924	0.77	0.71	7315	0.54	0.35	8028	0.30	6000	
1593	0.94	6678	0.66	0.63	7052	0.46	0.31	7734	0.25	6000	
1806	0.83	6763	0.59	0.55	7149	0.41	0.28	7948	0.23	6000	
1925	0.78	6850	0.56	0.52	7233	0.39	0.26	7929	0.22	6000	
2208	0.68	6978	0.50	0.45	7367	0.35	0.23	8074	0.19	6000	
2563	0.59	6470	0.40	0.39	6831	0.28	0.20	7488	0.15	6000	
2668	0.56	7157	0.42	0.37	7554	0.30	0.19	8277	0.16	6000	
3097	0.48	6636	0.34	0.32	7005	0.24	0.16	7677	0.13	6000	

Tutti i rapporti evidenziati (es. 10.50) hanno dimensioni particolari della coppia conica in certe versioni; vedere tavole dimensionali.

All ratios grey highlighted (ex. 10.50) have specific dimensions of the bevel gear set in some versions; see dimensional tables.

Alle mit (es. 10.50) gekennzeichneten Übersetzungen haben in bestimmten Versionen besondere Dimensionen des Kegelradtriebs. Siehe auch Dimensionstabellen.

Les rapports repérés par (es. 10.50) ont des dimensions de couple conique particulières. Voir les tableaux dimensionnels.

Todas las relaciones indicadas con (es. 10.50) tienen dimensiones particulares del par cónico según las versiones; ver las tablas de dimensión.

As relações marcadas com (es. 10.50) têm dimensões particulares da engrenagem cônica em certas versões; vide tabelas dimensionais.





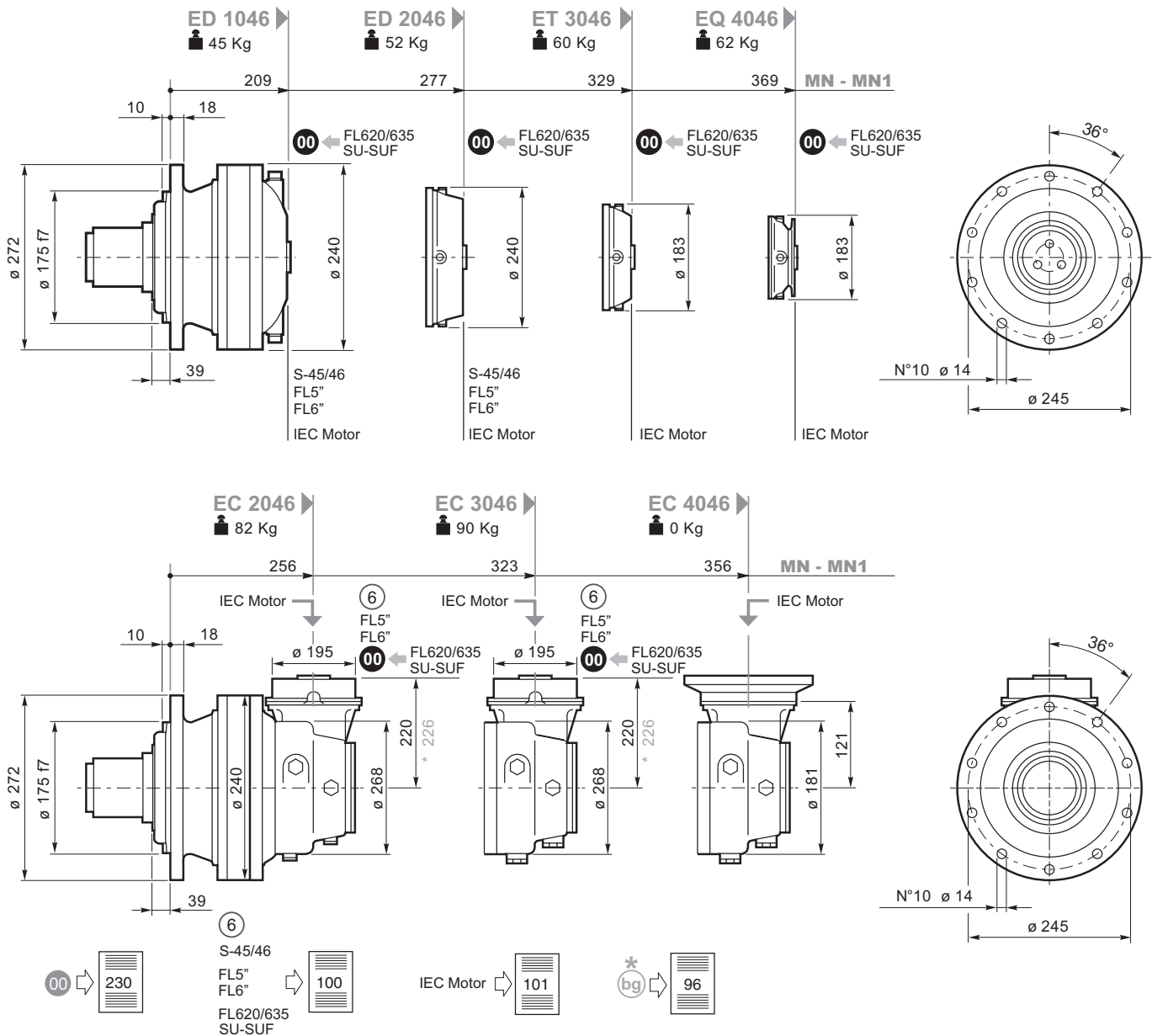
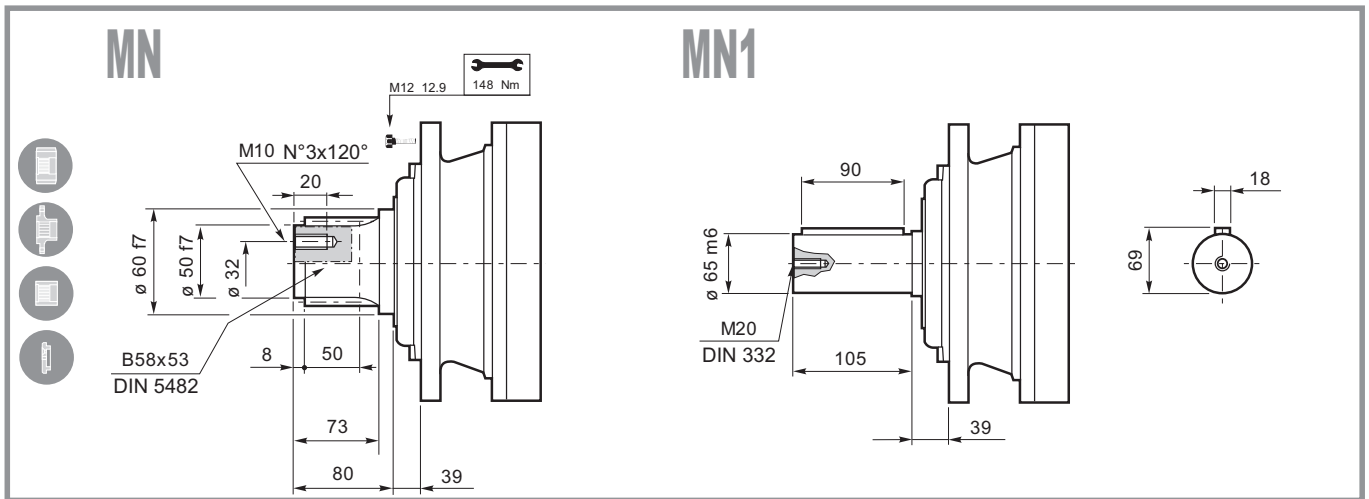



# 046

## S45CR1-S46C1

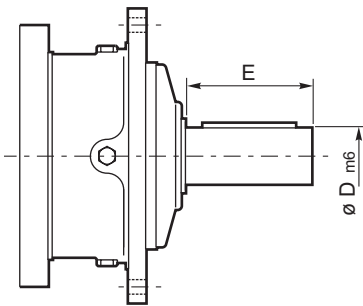

	D	E		Lt
				MN-MN1
S45 CR1	65	105	ED 2046	272
			ET 3046	340
S46 C1	65	105	ED 2046	313
			ET 3046	381

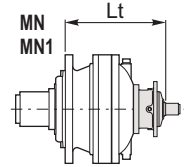

## SU2

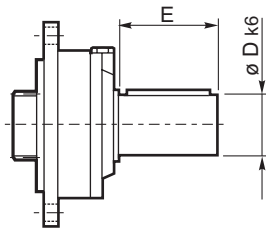

	D	E		Lt
				MN-MN1
SU 2	40	58	EM 1046	269
			ED 2046	337
			ET 3046	389
			EQ 4046	429

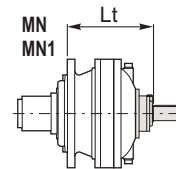

## ⑥ 48.82

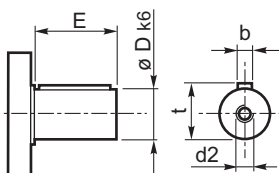

	D	E		Lt
				MN-MN1
48.82	48	82	EC 2046	280
			EC 3046	280

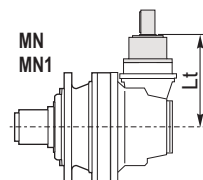

## FL250-FL350-FL450 FL750

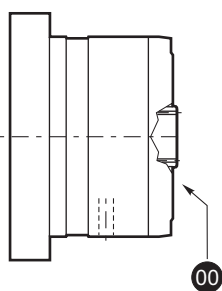

		Lt
		MN-MN1
FL250	EM 1046	302
	ED 2046	370
	EC 2046	280
FL350	EC 2046*	377
	EC 3046	280
FL450	EC 3046*	377
	EM 1046	315
FL750	ED 2046	383

**FL620/10**  
**FL635/10**

**FL620U-FL635U**

SAE A-AA  
Shaft FE

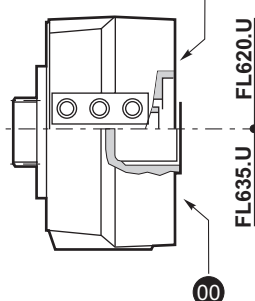

		Lt
		MN-MN1
FL620/U	EM 1046	313.5
	ED 2046	381.5
	ET 3046	433.5
	EQ 4046	473.5
	EC 2046	324.5
	EC 2046*	330.5
	EC 3046	324.5
FL635U	EC 3046*	330.5
	EM 1046	300
	ED 2046	368
	ET 3046	420
	EQ 4046	460
	EC 2046	311
	EC 2046*	317
FL620/10	EC 3046	311
	EC 3046*	317
	ED 2046	393
FL635/10	ET 3046	433
	ED 2046	374
	ET 3046	414

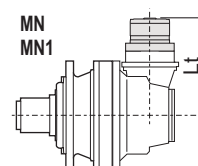
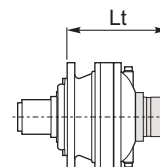

## IEC Motor

		Lt							
		IEC 63	IEC 71	IEC 80 90	IEC 100 112	IEC 132	IEC 160 180	IEC 200	IEC 225
EM 1046	MN-MN1	229	231	236	237	304	335	345	376
ED 2046	MN-MN1	297	299	304	305	372	403	413	444
ET 3046	MN-MN1	349	351	356	357	424			
EQ 4046	MN-MN1	389	391	396	397	464			
EC 2046	MN-MN1	240	242	247	248	315	346		
EC 2046*	MN-MN1	246	248	253	254	321	352		
EC 3046	MN-MN1	240	242	247	248	315	346		
EC 3046*	MN-MN1	246	248	253	254	321	352		
EC 4046*	MN-MN1	151	151	151	151	238			

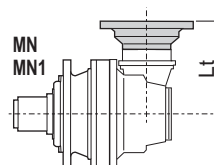
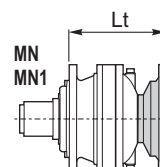

\* bg





**Flangia ruota**  
Driving flange  
Radnabenflansch  
Flasque de roue  
Brida de la rueda  
Flange de roda

## FA 046

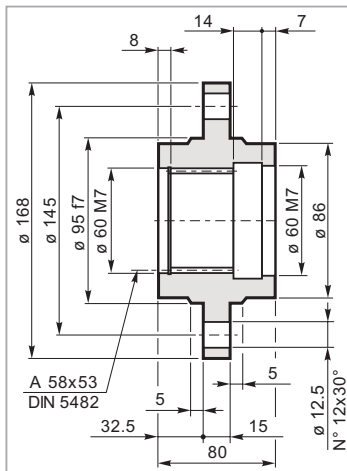

Mat. C40 UNI EN 10083  
Code: 34701241800



**Flangia ruota**  
Driving flange  
Radnabenflansch  
Flasque de roue  
Brida de la rueda  
Flange de roda

## FR 046

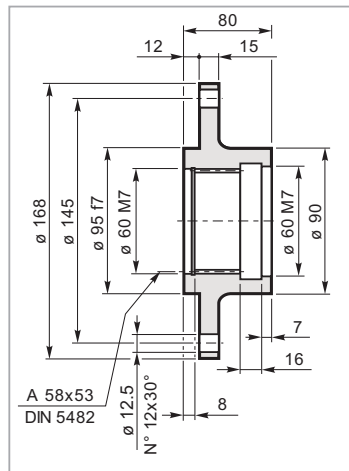

Mat. C40 UNI EN 10083  
Code: 34701141800



**Pignoni**  
Pinion  
Ritzel  
Pignon  
Piñones  
Pinhões

## IR 046

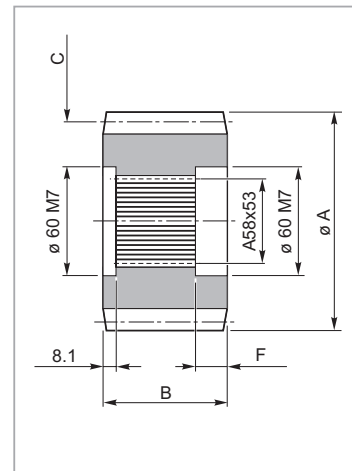

**Manicotto scanalato**  
Splined bush  
Keilmuffe  
Manchon cannelée  
Manguito acanalado  
Luva ranhurada

## MS 046

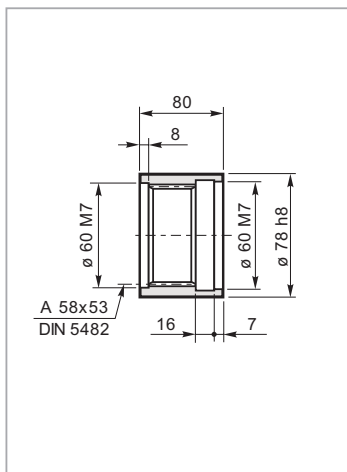

Mat. 39NiCrMo3 UNI EN 10083  
Code: 39102940600



**Rondella di fermo**  
Shaft cover  
Gegenscheibe  
Rondelle frein  
Arandela de bloqueo  
Amuela de encosto

## RDF 046

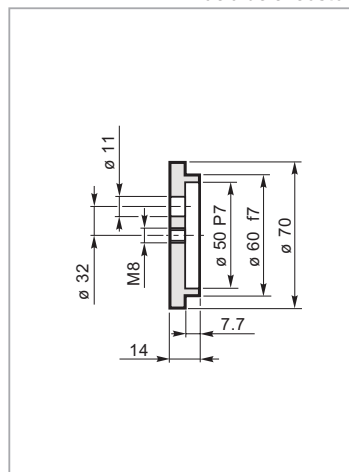

Mat. C40 UNI EN 10083  
Code: 37201040800

code	A	B	C			F
335.0143.0800	114.8	68	M=8	Z=12	X=0.3	23.5
335.0174.0800	99.6	68	M=6	Z=14	X=0.3	24
335.0184.0800	114.8	80	M=8	Z=12	X=0.3	24
335.0274.0800	143	80	M=10	Z=12	X=0.35	23.5
335.0324.0800	136.2	80	M=8	Z=15	—	23.5
335.0344.0800	152	80	M=10	Z=13	X=0.3	23.5
335.0353.000K	127.6	68	M=8	Z=13	X=0.54	23.5
335.2133.0600	143.4	80	M=8	Z=15	X=0.4	23.5
335.3473.0600	156	80	M=6	Z=24	—	23
335.4273.0600	142	80	M=8	Z=16	—	23.5
335.5193.060	115	68	M=5	Z=21	—	24
335.5942.000	136	80	M=8	Z=14	X=0.4	23.5
335.6273.000	120	68	M=8	Z=13	—	24



**Barra scanalata**  
Splined bar  
Zugspindel  
Barre cannelée  
Barra acanalada  
Barra ranhurada

## BS 046

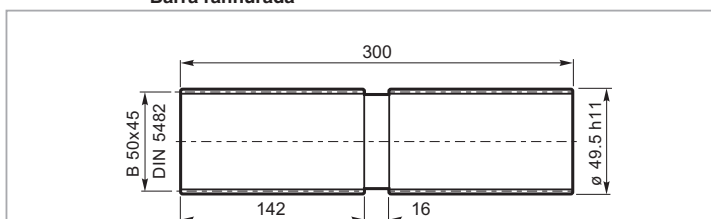

Mat. 39NiCrMo3 UNI EN 10083  
Code: 39126930100

Carichi radiali sugli alberi uscita / Radial loads on output shafts  
 Radiallasten auf de Abtriebswellen / Charges radiales sur les arbres de sortie  
 Cargas sobre los ejes de salida / Cargas radiais nos eixos de saida

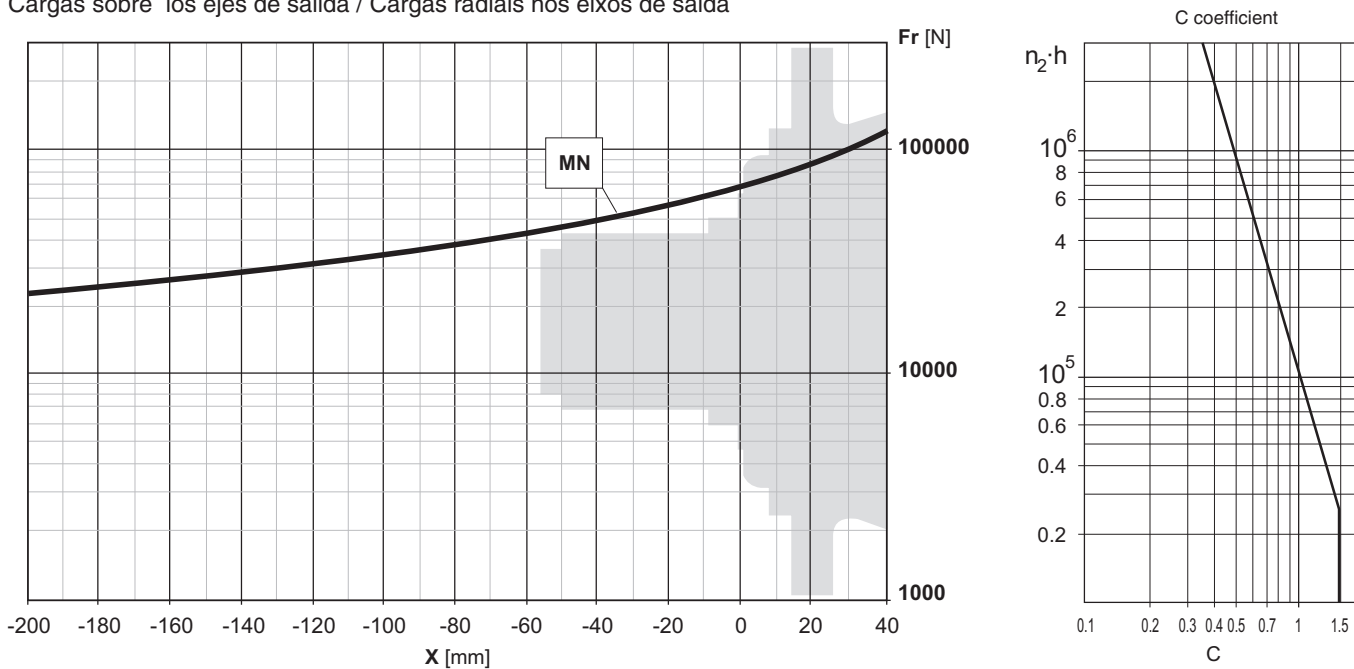

Carichi assiali / Axial loads / Axialkräfte / Charges axiales / Cargas axiales / Forças axiais

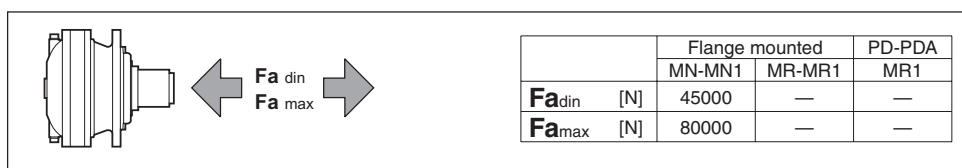

Carichi radiali sugli alberi entrata / Radial loads on input shafts  
 Radiallasten auf de Antriebswellen / Charges radiales sur les arbres d'entrée  
 Cargas sobre los ejes de entrada / Cargas radiais nos eixos de entrada

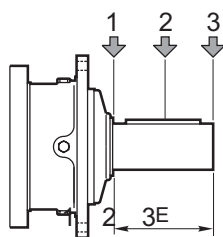

Type	E	$Fr$ [N]					
		$n_1 \cdot h = 10^7$			$n_1 \cdot h = 10^8$		
		1	2	3	1	2	3
S45 CR1	105	10000	6000	4000	5000	3000	2000
S46 C1	105	104000	8800	6400	7000	4400	3200

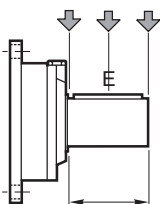

Type	E	$Fr$ [N]					
		$n_1 \cdot h = 10^7$			$n_1 \cdot h = 10^8$		
		1	2	3	1	2	3
SU2	58	3000	2000	1500	1400	1000	700

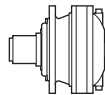

i <sub>eff</sub>	n <sub>1</sub> [min <sup>-1</sup> ]									T <sub>2max</sub> [Nm]	P <sub>T</sub> [kW]	
	1500			1000			500					
	n <sub>2</sub> [min <sup>-1</sup> ]	T <sub>2</sub> [Nm]	P <sub>2</sub> [kW]	n <sub>2</sub> [min <sup>-1</sup> ]	T <sub>2</sub> [Nm]	P <sub>2</sub> [kW]	n <sub>2</sub> [min <sup>-1</sup> ]	T <sub>2</sub> [Nm]	P <sub>2</sub> [kW]			
<b>EM 1065</b>												
3.50	429	2241	101	286	2531	76	143	3116	46.6	10000	30	
3.86	389	2307	94	259	2605	71	130	3207	43.5	10000		
4.33	346	2346	85	231	2650	64	115	3262	39.5	10000		
5.00	300	2401	75	200	2712	57	100	3338	35.0	10000		
6.00	250	2502	66	167	2826	49.3	83	3480	30.4	10000		
<b>ED 2065</b>												
10.78	139	3110	45.3	93	3512	34.1	46.4	4324	21.0	9800	18	
12.25	122	3264	41.9	82	3686	31.5	40.8	4538	19.4	9800		
13.51	111	3359	39.1	74	3794	29.4	37.0	4671	18.1	10000		
15.16	99	3417	35.4	66	3859	26.7	33.0	4751	16.4	10000		
17.88	84	3590	31.5	56	4055	23.8	28.0	4992	14.6	10000		
20.65	73	3674	28.0	48.4	4150	21.0	24.2	5109	13.0	10000		
22.39	67	3841	27.0	44.7	4338	20.3	22.3	5340	12.5	10000		
25.98	58	4016	24.3	38.5	4536	18.3	19.2	5140	10.4	10000		
27.99	54	3334	18.7	35.7	3567	13.3	17.9	3918	7.3	10000		
30.00	50	4110	21.5	33.3	4642	16.2	16.7	5479	9.6	10000		
36.25	41.4	4319	18.7	27.6	4620	13.3	13.8	5075	7.3	10000		
43.50	34.5	3971	14.3	23.0	4137	10.0	11.5	4422	5.3	10000		
<b>ET 3065</b>												
51.22	29.3	4924	15.1	19.5	5561	11.4	9.8	6150	6.3	10000		14
53.78	27.9	5087	14.9	18.6	5745	11.2	9.3	7073	6.9	10000		
60.44	24.8	5174	13.4	16.5	5844	10.1	8.3	6246	5.4	10000		
73.50	20.4	5058	10.8	13.6	5549	7.9	6.8	6254	4.5	10000		
78.51	19.1	5597	11.2	12.7	6005	8.0	6.4	6603	4.4	10000		
90.93	16.5	5849	10.1	11.0	6085	7.0	5.5	6810	3.9	10000		
98.27	15.3	5841	9.3	10.2	6112	6.5	5.1	6560	3.5	10000		
110.6	13.6	6079	8.6	9.0	6361	6.0	4.5	7297	3.5	10000		
123.9	12.1	5642	7.2	8.1	5851	4.9	4.0	6651	2.8	10000		
134.3	11.2	6051	7.1	7.4	6315	4.9	3.7	6760	2.6	10000		
155.1	9.7	5757	5.8	6.4	6024	4.1	3.2	6968	2.4	10000		
180.0	8.3	5834	5.1	5.6	6219	3.6	2.8	7170	2.1	10000		
208.2	7.2	5910	4.5	4.8	6413	3.2	2.4	7269	1.8	10000		
217.5	6.9	5495	4.0	4.6	5735	2.8	2.3	6146	1.5	10000		
251.6	6.0	5581	3.5	4.0	5821	2.4	2.0	6233	1.3	10000		
272.8	5.5	5375	3.1	3.7	5552	2.1	1.8	5838	1.1	10000		
<b>EQ 4065</b>												
322.7	4.6	7604	3.7	3.1	7906	2.6	1.5	9121	1.5	10000	8	
373.2	4.0	7704	3.2	2.7	8152	2.3	1.3	9392	1.3	10000		
411.6	3.6	7683	2.9	2.4	8332	2.1	1.2	9537	1.2	10000		
441.0	3.4	6873	2.4	2.3	7218	1.7	1.1	7800	0.93	10000		
510.1	2.9	6998	2.2	2.0	7341	1.5	0.98	7923	0.81	10000		
555.3	2.7	7619	2.2	1.8	7992	1.5	0.90	8626	0.81	10000		
631.1	2.4	8077	2.0	1.6	8750	1.5	0.79	9802	0.81	10000		
696.2	2.2	7397	1.7	1.4	7774	1.2	0.72	8406	0.63	10000		
771.8	1.9	7348	1.5	1.3	7688	1.0	0.65	8274	0.56	10000		
892.7	1.7	6595	1.2	1.1	6907	0.81	0.56	7448	0.44	10000		
994.6	1.5	8119	1.3	1.0	8789	0.93	0.50	10034	0.53	10000		
1104	1.4	8159	1.2	0.91	8545	0.81	0.45	9215	0.44	10000		
1303	1.2	9309	1.1	0.77	10058	0.81	0.38	10873	0.44	10000		
1445	1.0	7916	0.86	0.69	8637	0.63	0.35	9973	0.36	10000		
1631	0.92	8185	0.79	0.61	8905	0.57	0.31	10239	0.33	10000		
1884	0.80	9194	0.77	0.53	9932	0.55	0.27	11303	0.31	10000		
2095	0.72	7243	0.54	0.48	7839	0.39	0.24	8946	0.22	10000		
2186	0.69	8653	0.62	0.46	9419	0.45	0.23	10840	0.26	10000		
2468	0.61	5462	0.35	0.41	5604	0.24	0.20	5852	0.12	10000		
2850	0.53	6307	0.35	0.35	6471	0.24	0.18	6757	0.12	10000		
3170	0.47	7852	0.39	0.32	8486	0.28	0.16	9665	0.16	10000		

**1500**  
HOURS LIFE

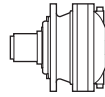

**065**

i <sub>eff</sub>	n <sub>1</sub> [min <sup>-1</sup> ]									T <sub>2max</sub> [Nm]	P <sub>T</sub> [kW]	
	1500			1000			500					
	n <sub>2</sub> [min <sup>-1</sup> ]	T <sub>2</sub> [Nm]	P <sub>2</sub> [kW]	n <sub>2</sub> [min <sup>-1</sup> ]	T <sub>2</sub> [Nm]	P <sub>2</sub> [kW]	n <sub>2</sub> [min <sup>-1</sup> ]	T <sub>2</sub> [Nm]	P <sub>2</sub> [kW]			
<b>EM 1065</b>												
3.50	429	3960	178	286	4472	134	143	5506	82	10000	30	
3.86	389	4076	166	259	4603	125	130	5667	77	10000		
4.33	346	4145	150	231	4682	113	115	5715	69	10000		
5.00	300	4242	133	200	4791	100	100	5438	57	10000		
6.00	250	3746	98	167	3975	69	83	4323	37.7	10000		
<b>ED 2065</b>												
10.78	139	5495	80	93	6205	60	46.4	7412	36.0	9800	18	
12.25	122	5767	74	82	6430	55	40.8	7159	30.6	9800		
13.51	111	5836	68	74	6101	47.3	37.0	7004	27.1	10000		
15.16	99	5816	60	66	6071	42.0	33.0	6924	23.9	10000		
17.88	84	5921	52	56	6172	36.1	28.0	7171	21.0	10000		
20.65	73	5627	42.8	48.4	5859	29.7	24.2	6775	17.2	10000		
22.39	67	5648	39.6	44.7	6066	28.4	22.3	6667	15.6	10000		
25.98	58	5282	31.9	38.5	5634	22.7	19.2	6154	12.4	10000		
27.99	54	4086	22.9	35.7	4338	16.2	17.9	4724	8.8	10000		
30.00	50	5841	30.6	33.3	6327	22.1	16.7	7107	12.4	10000		
36.25	41.4	5292	22.9	27.6	5619	16.2	13.8	6119	8.8	10000		
43.50	34.5	4777	17.3	23.0	5229	12.6	11.5	6061	7.3	10000		
<b>ET 3065</b>												
51.22	29.3	7101	21.8	19.5	7725	15.8	9.8	8874	9.1	10000		14
53.78	27.9	7500	21.9	18.6	7965	15.5	9.3	9256	9.0	10000		
60.44	24.8	7352	19.1	16.5	7990	13.8	8.3	9165	7.9	10000		
73.50	20.4	6404	13.7	13.6	6932	9.9	6.8	7700	5.5	10000		
78.51	19.1	7759	15.5	12.7	8420	11.2	6.4	9640	6.4	10000		
90.93	16.5	7923	13.7	11.0	8576	9.9	5.5	9526	5.5	10000		
98.27	15.3	6962	11.1	10.2	7271	7.7	5.1	8473	4.5	10000		
110.6	13.6	7593	10.8	9.0	8176	7.7	4.5	9050	4.3	10000		
123.9	12.1	7813	9.9	8.1	8469	7.2	4.0	9684	4.1	10000		
134.3	11.2	7195	8.4	7.4	7801	6.1	3.7	9049	3.5	10000		
155.1	9.7	8172	8.3	6.4	8849	6.0	3.2	10105	3.4	10000		
180.0	8.3	7649	6.7	5.6	8256	4.8	2.8	9578	2.8	10000		
208.2	7.2	7788	5.9	4.8	8524	4.3	2.4	9872	2.5	10000		
217.5	6.9	6585	4.8	4.6	7087	3.4	2.3	8256	2.0	10000		
251.6	6.0	6681	4.2	4.0	7324	3.0	2.0	8516	1.8	10000		
272.8	5.5	6039	3.5	3.7	6238	2.4	1.8	6559	1.3	10000		
<b>EQ 4065</b>												
322.7	4.6	10210	5.0	3.1	10398	3.4	1.5	10675	1.7	10000	8	
373.2	4.0	10281	4.3	2.7	10460	2.9	1.3	10728	1.5	10000		
411.6	3.6	11085	4.2	2.4	11536	2.9	1.2	11832	1.5	10000		
441.0	3.4	8383	3.0	2.3	9136	2.2	1.1	9796	1.2	10000		
510.1	2.9	8557	2.6	2.0	9469	1.9	0.98	9941	1.0	10000		
555.3	2.7	9315	2.6	1.8	10308	1.9	0.90	10823	1.0	10000		
631.1	2.4	10586	2.6	1.6	11714	1.9	0.79	12299	1.0	10000		
696.2	2.2	9081	2.0	1.4	10074	1.5	0.72	11551	0.87	10000		
771.8	1.9	9488	1.9	1.3	9754	1.3	0.65	10616	0.72	10000		
892.7	1.7	8555	1.5	1.1	9394	1.1	0.56	10450	0.61	10000		
994.6	1.5	11638	1.8	1.0	12531	1.3	0.50	14190	0.75	10000		
1104	1.4	10584	1.5	0.91	11622	1.1	0.45	12928	0.61	10000		
1303	1.2	12489	1.5	0.77	13715	1.1	0.38	15255	0.61	10000		
1445	1.0	11686	1.3	0.69	12645	0.92	0.35	14425	0.52	10000		
1631	0.92	11951	1.2	0.61	12908	0.83	0.31	14685	0.47	10000		
1884	0.80	13070	1.1	0.53	14053	0.78	0.27	15880	0.44	10000		
2095	0.72	10373	0.78	0.48	11167	0.56	0.24	12642	0.32	10000		
2186	0.69	12666	0.91	0.46	13686	0.66	0.23	15579	0.37	10000		
2468	0.61	6338	0.40	0.41	6744	0.29	0.20	7495	0.16	10000		
2850	0.53	7319	0.40	0.35	7787	0.29	0.18	8655	0.16	10000		
3170	0.47	11184	0.55	0.32	12029	0.40	0.16	13600	0.23	10000		



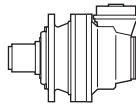

$i_{\text{eff}}$	$n_1$ [min <sup>-1</sup> ]									$T_{2\text{max}}$ [Nm]	$P_T$ [kW]	
	1500			1000			500					
	$n_2$ [min <sup>-1</sup> ]	$T_2$ [Nm]	$P_2$ [kW]	$n_2$ [min <sup>-1</sup> ]	$T_2$ [Nm]	$P_2$ [kW]	$n_2$ [min <sup>-1</sup> ]	$T_2$ [Nm]	$P_2$ [kW]			
<b>EC 2065 - PDA 2065</b>												
10.50	143	2368	35.4	95	2674	26.7	47.6	3292	16.4	10000	14	
11.58	130	2611	35.4	86	2949	26.7	43.2	3631	16.4	10000		
12.99	115	2929	35.4	77	3308	26.7	38.5	4073	16.4	10000		
16.17	93	1582	15.4	62	1787	11.6	30.9	2200	7.1	10000		
17.83	84	1745	15.4	56	1971	11.6	28.0	2426	7.1	10000		
20.00	75	1957	15.4	50	2211	11.6	25.0	2722	7.1	10000		
23.10	65	2260	15.4	43.3	2553	11.6	21.6	3143	7.1	10000		
27.72	54	2713	15.4	36.1	3063	11.6	18.0	3772	7.1	10000		
<b>EC 3065 - PDA 3065</b>												
40.53	37.0	4671	18.1	24.7	5275	13.6	12.3	6131	7.9	10000	11	
45.47	33.0	4751	16.4	22.0	5365	12.4	11.0	6085	7.0	10000		
49.80	30.1	4874	15.4	20.1	5504	11.6	10.0	6777	7.1	10000		
56.60	26.5	5166	14.3	17.7	5834	10.8	8.8	7164	6.6	10000		
62.42	24.0	5317	13.4	16.0	5987	10.0	8.0	6527	5.5	10000		
70.02	21.4	5408	12.1	14.3	5944	8.9	7.1	6445	4.8	10000		
80.85	18.6	5424	10.5	12.4	5631	7.3	6.2	6079	3.9	10000		
92.20	16.3	5238	8.9	10.8	5478	6.2	5.4	5877	3.3	10000		
103.4	14.5	5875	8.9	9.7	6145	6.2	4.8	6592	3.3	10000		
108.8	13.8	5075	7.3	9.2	5323	5.1	4.6	5735	2.8	10000		
120.0	12.5	5408	7.1	8.3	5650	4.9	4.2	6056	2.6	10000		
138.6	10.8	5699	6.5	7.2	5909	4.5	3.6	6808	2.6	10000		
166.3	9.0	4523	4.3	6.0	4695	3.0	3.0	5404	1.7	10000		
201.0	7.5	4603	3.6	5.0	4846	2.5	2.5	5624	1.5	10000		
<b>EC 4065 - PDA 4065</b>												
220.5	6.8	6254	4.5	4.5	6623	3.1	2.3	7218	1.7	10000		7
255.0	5.9	5607	3.5	3.9	5936	2.4	2.0	6476	1.3	10000		
281.3	5.3	6184	3.5	3.6	6546	2.4	1.8	7142	1.3	10000		
315.5	4.8	6937	3.5	3.2	7343	2.4	1.6	8012	1.3	10000		
359.4	4.2	6696	2.9	2.8	7045	2.1	1.4	7629	1.1	10000		
415.7	3.6	6001	2.3	2.4	6318	1.6	1.2	6852	0.86	10000		
451.1	3.3	5815	2.0	2.2	6567	1.5	1.1	8085	0.94	10000		
498.3	3.0	6424	2.0	2.0	7255	1.5	1.0	7903	0.83	10000		
576.4	2.6	6257	1.7	1.7	6570	1.2	0.87	7105	0.65	10000		
635.7	2.4	6901	1.7	1.6	7246	1.2	0.79	7836	0.65	10000		
713.1	2.1	7741	1.7	1.4	8128	1.2	0.70	8791	0.65	10000		
823.4	1.8	7820	1.5	1.2	8472	1.1	0.61	9682	0.62	10000		
892.9	1.7	7513	1.3	1.1	7794	0.91	0.56	9031	0.53	10000		
1018	1.5	7603	1.2	0.98	8012	0.82	0.49	9281	0.48	10000		
1149	1.3	5199	0.71	0.87	5338	0.49	0.44	5579	0.25	10000		
1220	1.2	7729	1.0	0.82	8332	0.72	0.41	9635	0.41	10000		
1412	1.1	7876	0.88	0.71	8594	0.64	0.35	9926	0.37	10000		
1594	0.94	5311	0.52	0.63	5451	0.36	0.31	5694	0.19	10000		
1840	0.82	6133	0.52	0.54	6295	0.36	0.27	6575	0.19	10000		
1861	0.81	6874	0.58	0.54	7520	0.42	0.27	8717	0.25	10000		
2136	0.70	7118	0.52	0.47	7305	0.36	0.23	7631	0.19	10000		
2581	0.58	7391	0.45	0.39	8069	0.33	0.19	9221	0.19	10000		
3097	0.48	7817	0.40	0.32	8449	0.29	0.16	9623	0.16	10000		

Tutti i rapporti evidenziati (es. 10.50) hanno dimensioni particolari della coppia conica in certe versioni; vedere tavole dimensionali.

All ratios grey highlighted (ex. 10.50) have specific dimensions of the bevel gear set in some versions; see dimensional tables.

Alle mit (es. 10.50) gekennzeichneten Übersetzungen haben in bestimmten Versionen besondere Dimensionen des Kegelradtriebs. Siehe auch Dimensionstabellen.

Les rapports repérés par (es. 10.50) ont des dimensions de couple conique particulières. Voir les tableaux dimensionnels.

Todas las relaciones indicadas con (es. 10.50) tienen dimensiones particulares del par cónico según las versiones; ver las tablas de dimensión.

As relações marcadas com (es. 10.50) têm dimensões particulares da engrenagem cônica em certas versões; vide tabelas dimensionais.



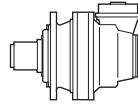

$i_{eff}$	$n_1$ [min <sup>-1</sup> ]									$T_{2max}$ [Nm]	$P_T$ [kW]
	1500			1000			500				
	$n_2$ [min <sup>-1</sup> ]	$T_2$ [Nm]	$P_2$ [kW]	$n_2$ [min <sup>-1</sup> ]	$T_2$ [Nm]	$P_2$ [kW]	$n_2$ [min <sup>-1</sup> ]	$T_2$ [Nm]	$P_2$ [kW]		

**EC 2065 - PDA 2065**

10.50	143	4183	63	95	4724	47.1	47.6	5817	29.0	10000	14
11.58	130	4614	63	86	5210	47.1	43.2	6415	29.0	10000	
12.99	115	5175	63	77	5845	47.1	38.5	6698	27.0	10000	
16.17	93	2796	27.2	62	3157	20.5	30.9	3887	12.6	10000	
17.83	84	3083	27.2	56	3482	20.5	28.0	4287	12.6	10000	
20.00	75	3459	27.2	50.0	3906	20.5	25.0	4809	12.6	10000	
23.10	65	3994	27.2	43.3	4511	20.5	21.6	5553	12.6	10000	
27.72	54	4526	25.6	36.1	4728	17.9	18.0	5511	10.4	10000	

**EC 3065 - PDA 3065**

40.53	37.0	7004	27.1	24.7	7629	19.7	12.3	8775	11.3	10000	11
45.47	33.0	6924	23.9	22.0	7538	17.4	11.0	8668	10.0	10000	
49.80	30.1	7822	24.7	20.1	8419	17.7	10.0	9781	10.3	10000	
56.60	26.5	7544	20.9	17.7	8057	14.9	8.8	9355	8.7	10000	
62.42	24.0	7670	19.3	16.0	8330	14.0	8.0	9547	8.0	10000	
70.02	21.4	7579	17.0	14.3	8230	12.3	7.1	9430	7.1	10000	
80.85	18.6	7162	13.9	12.4	7780	10.1	6.2	8921	5.8	10000	
92.20	16.3	6241	10.6	10.8	6558	7.4	5.4	7636	4.3	10000	
103.4	14.5	7001	10.6	9.7	7356	7.4	4.8	8566	4.3	10000	
108.8	13.8	6119	8.8	9.2	6394	6.2	4.6	7087	3.4	10000	
120.0	12.5	6450	8.4	8.3	6742	5.9	4.2	7851	3.4	10000	
138.6	10.8	7449	8.4	7.2	7786	5.9	3.6	9066	3.4	10000	
166.3	9.0	6371	6.0	6.0	6915	4.4	3.0	7923	2.5	10000	
201.0	7.5	6621	5.2	5.0	7180	3.7	2.5	8217	2.1	10000	

**EC 4065 - PDA 4065**

220.5	6.8	7700	5.5	4.5	8106	3.9	2.3	9136	2.2	10000	7
255.0	5.9	6954	4.3	3.9	7317	3.0	2.0	8230	1.7	10000	
281.3	5.3	7670	4.3	3.6	8070	3.0	1.8	9077	1.7	10000	
315.5	4.8	8604	4.3	3.2	9053	3.0	1.6	10182	1.7	10000	
359.4	4.2	8187	3.6	2.8	8679	2.5	1.4	9732	1.4	10000	
415.7	3.6	7390	2.8	2.4	7808	2.0	1.2	9283	1.2	10000	
451.1	3.3	9893	3.4	2.2	10291	2.4	1.1	11056	1.3	10000	
498.3	3.0	8505	2.7	2.0	9415	2.0	1.0	9904	1.0	10000	
576.4	2.6	7674	2.1	1.7	8487	1.5	0.87	9753	0.89	10000	
635.7	2.4	8464	2.1	1.6	9361	1.5	0.79	10756	0.89	10000	
713.1	2.1	9494	2.1	1.4	10500	1.5	0.70	12065	0.89	10000	
823.4	1.8	10963	2.1	1.2	12108	1.5	0.61	13721	0.87	10000	
892.9	1.7	10618	1.9	1.1	11513	1.4	0.56	13170	0.77	10000	
1018	1.5	10902	1.7	0.98	11813	1.2	0.49	13503	0.69	10000	
1149	1.3	5841	0.80	0.87	5998	0.55	0.44	6671	0.30	10000	
1220	1.2	11303	1.5	0.82	12239	1.1	0.41	13974	0.60	10000	
1412	1.1	11632	1.3	0.71	12588	0.93	0.35	14362	0.53	10000	
1594	0.94	5967	0.59	0.63	6307	0.41	0.31	7012	0.23	10000	
1840	0.82	6890	0.59	0.54	7283	0.41	0.27	8097	0.23	10000	
1861	0.81	9458	0.80	0.54	9712	0.55	0.27	10803	0.30	10000	
2136	0.70	7996	0.59	0.47	8452	0.41	0.23	9397	0.23	10000	
2581	0.58	9662	0.59	0.39	10213	0.41	0.19	11355	0.23	10000	
3097	0.48	11137	0.57	0.32	11979	0.41	0.16	13544	0.23	10000	

Tutti i rapporti evidenziati (es. 10.50) hanno dimensioni particolari della coppia conica in certe versioni; vedere tavole dimensionali.

All ratios grey highlighted (ex. 10.50) have specific dimensions of the bevel gear set in some versions; see dimensional tables.

Alle mit (es. 10.50) gekennzeichneten Übersetzungen haben in bestimmten Versionen besondere Dimensionen des Kegelradtriebs. Siehe auch Dimensionstabellen.

Les rapports repérés par (es. 10.50) ont des dimensions de couple conique particulières. Voir les tableaux dimensionnels.

Todas las relaciones indicadas con (es. 10.50) tienen dimensiones particulares del par cónico según las versiones; ver las tablas de dimensión.

As relações marcadas com (es. 10.50) têm dimensões particulares da engrenagem cônica em certas versões; vide tabelas dimensionais.



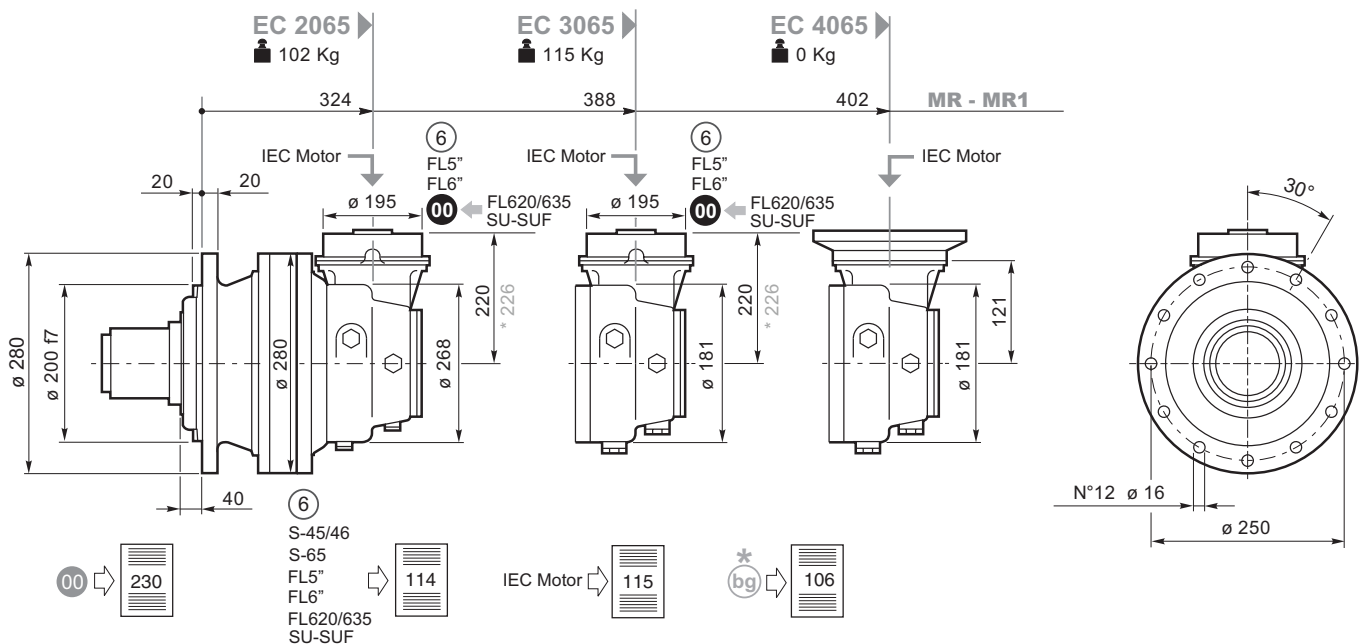
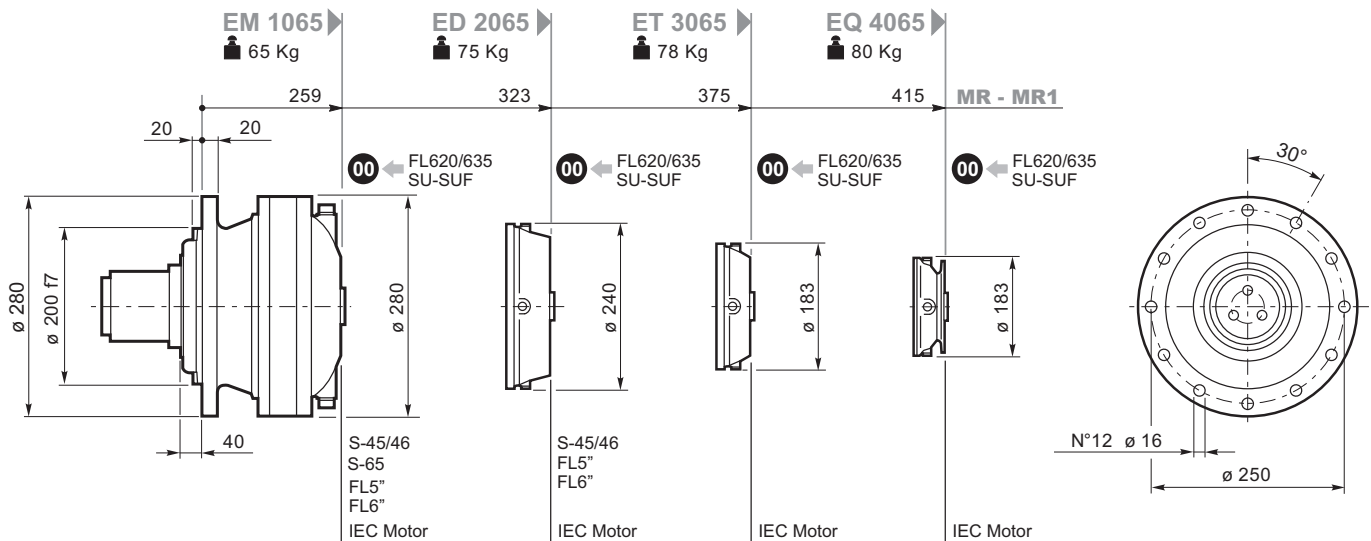
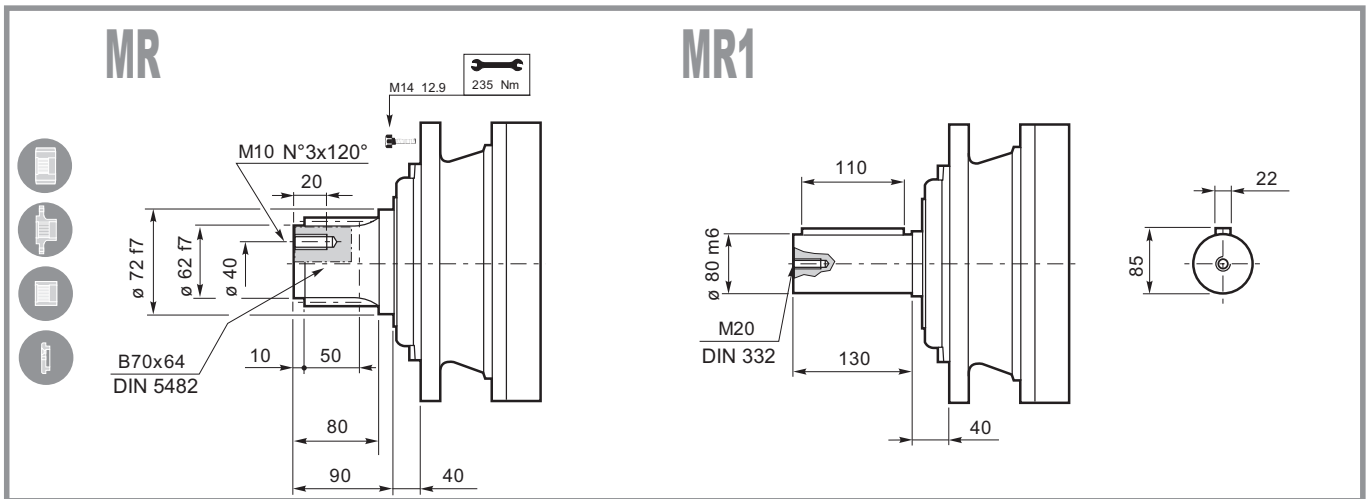

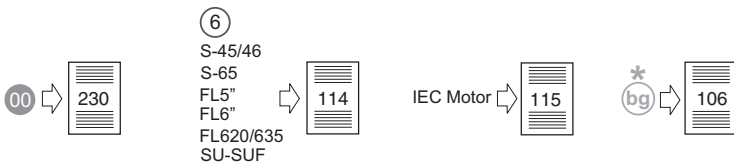
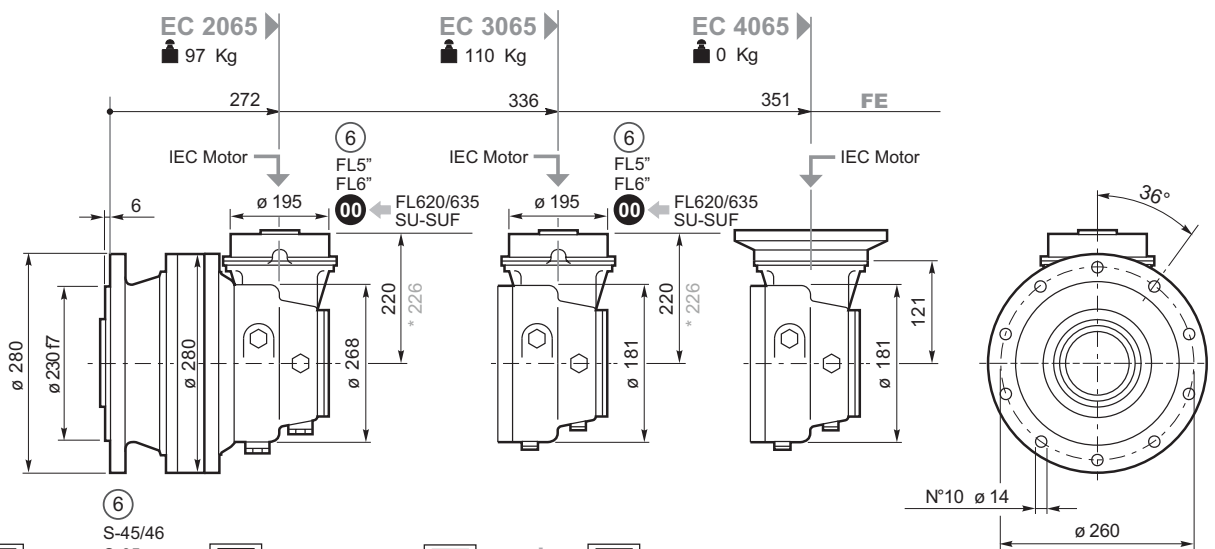
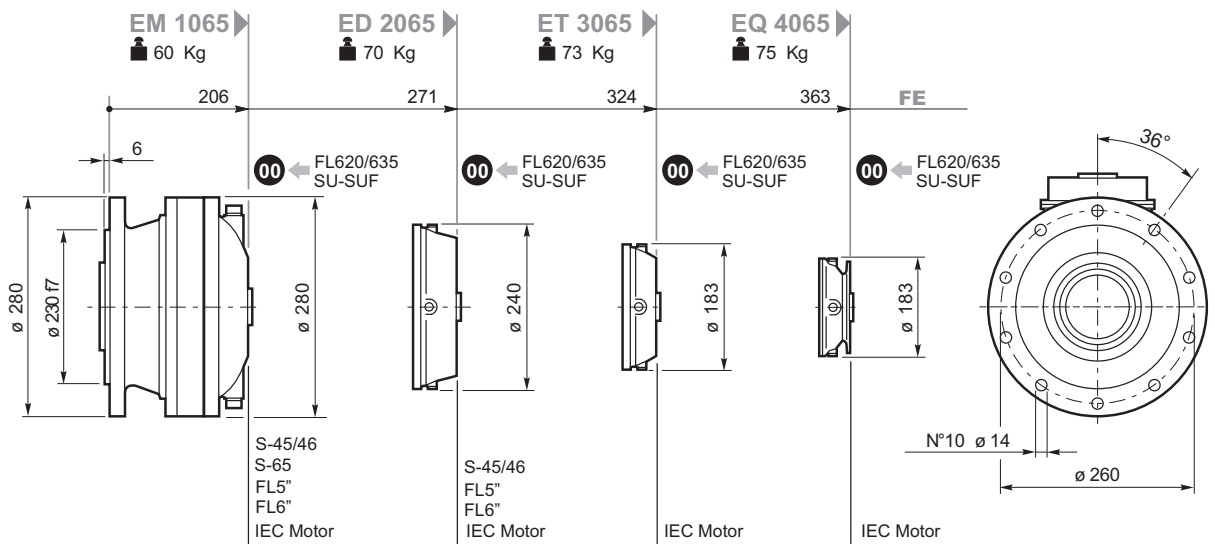
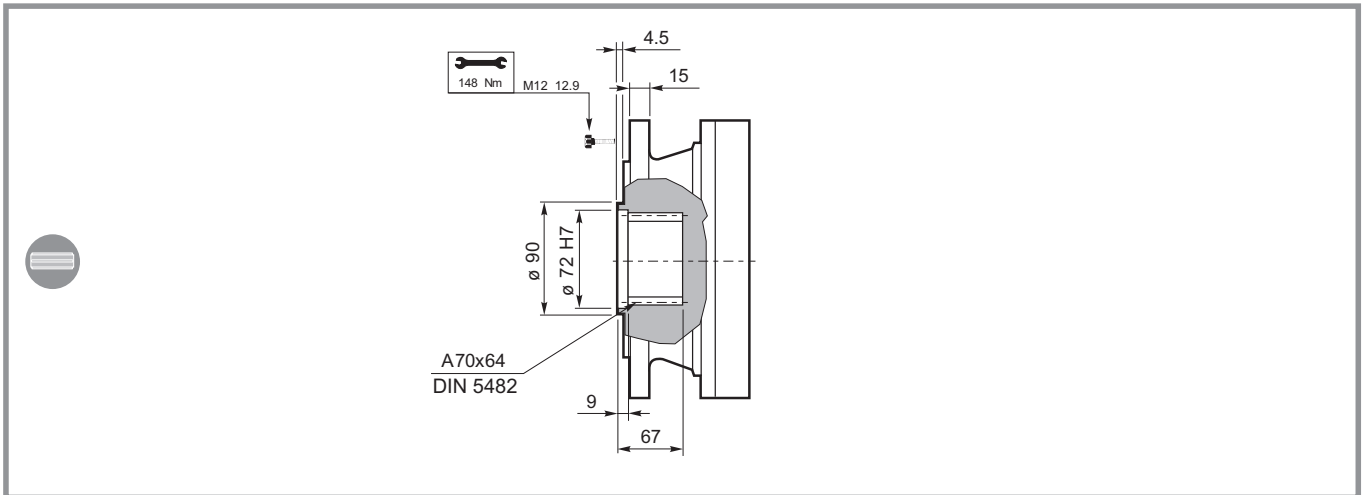

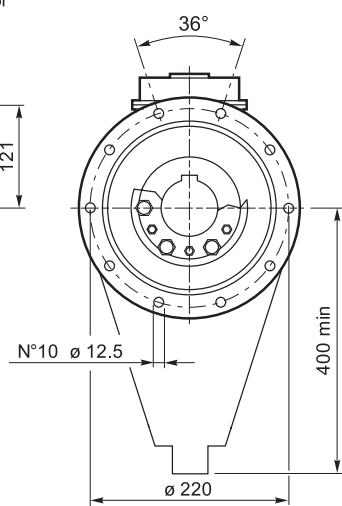
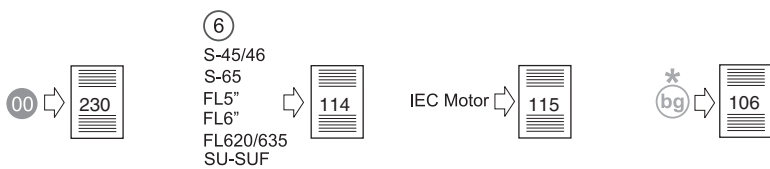
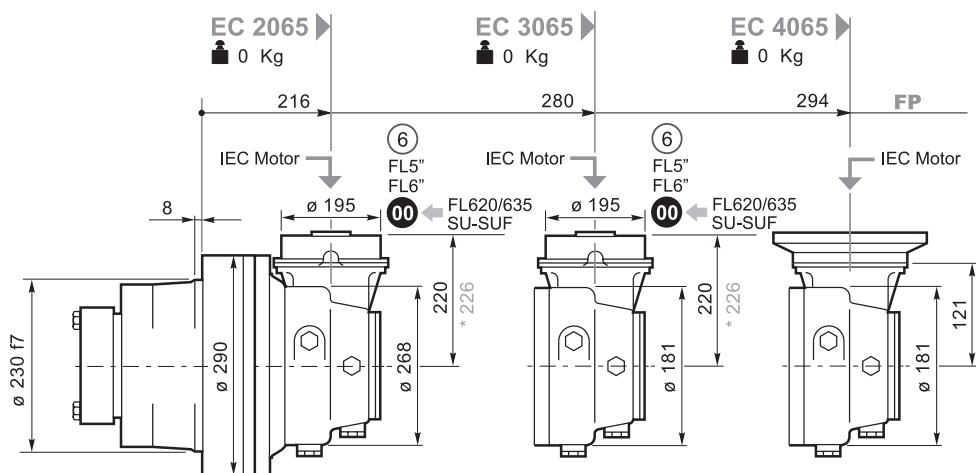
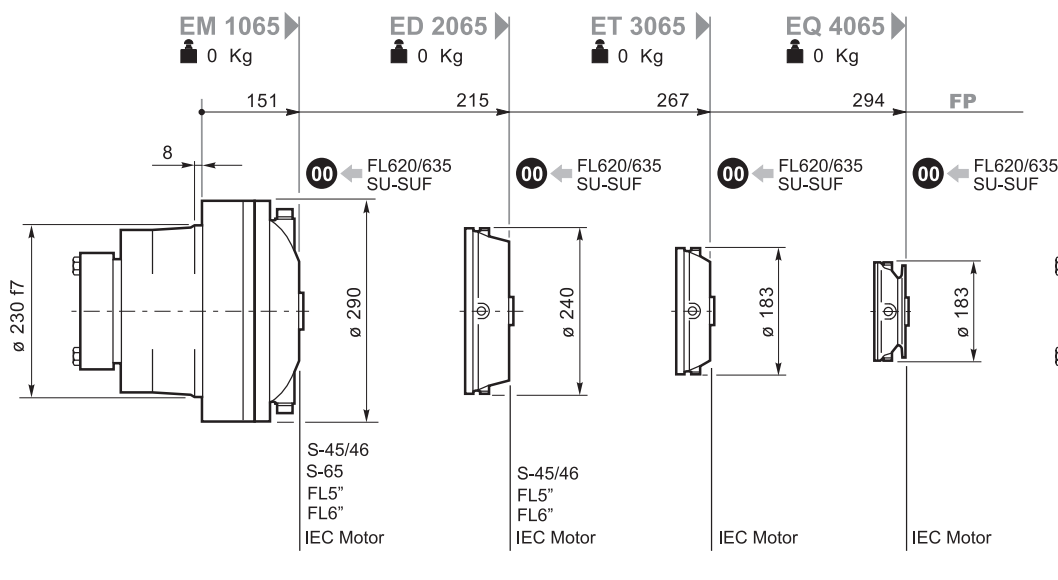
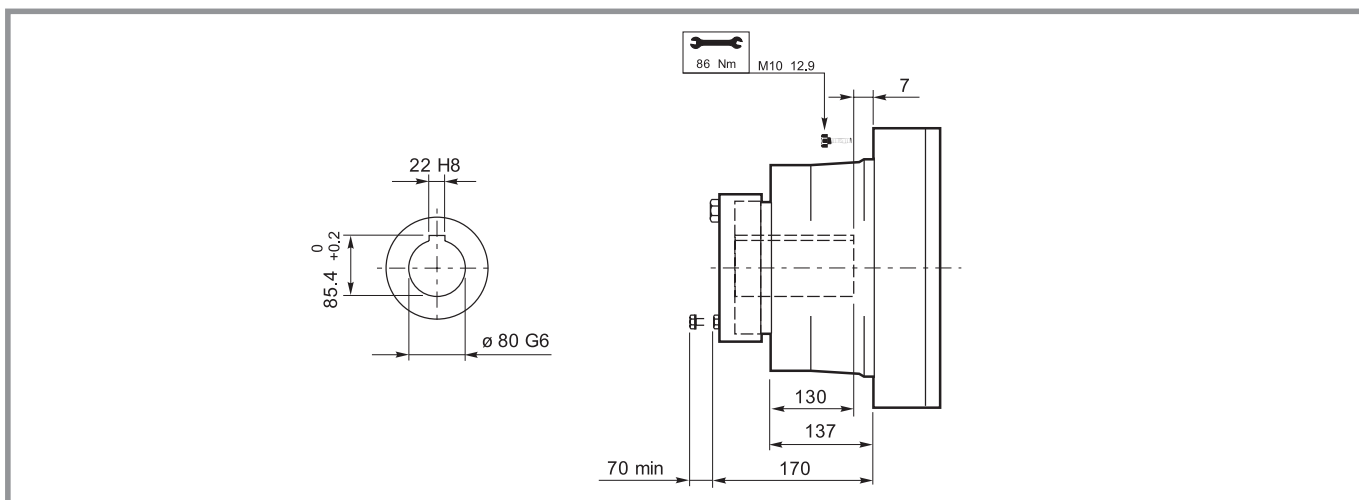

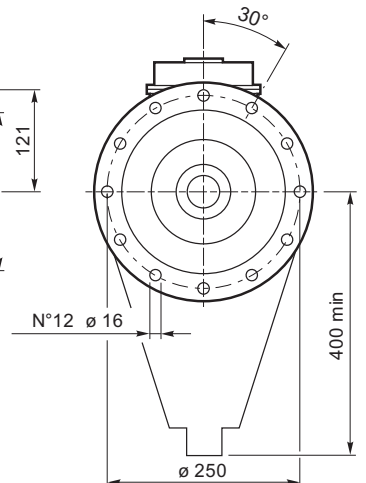
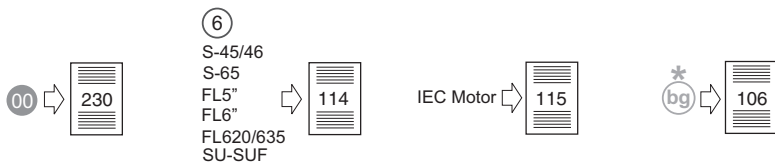
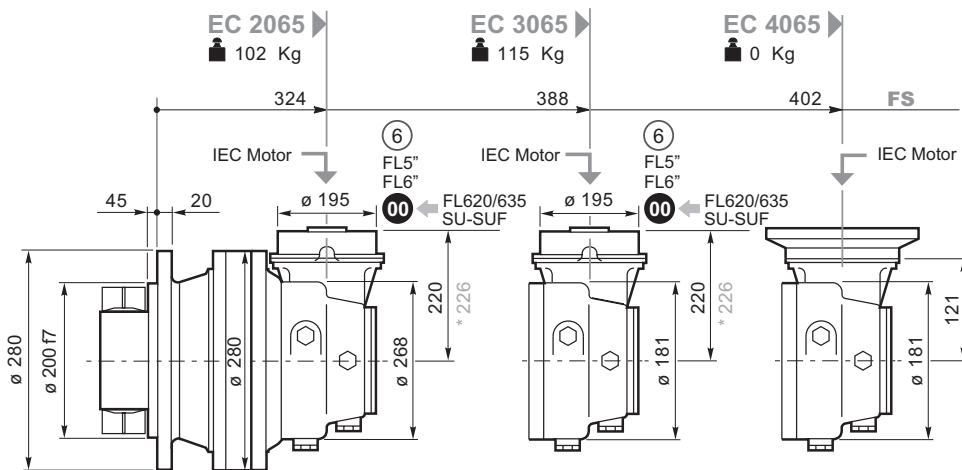
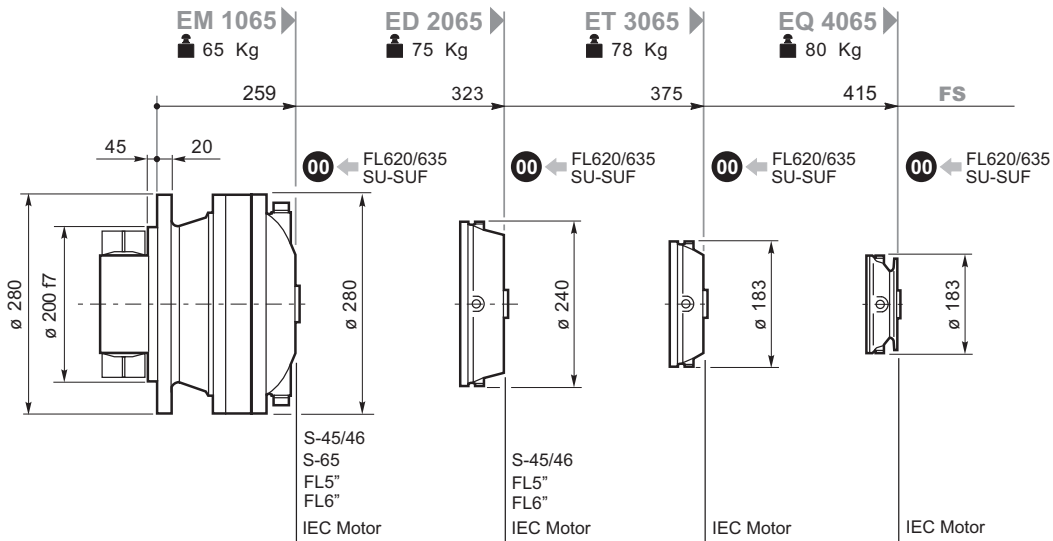
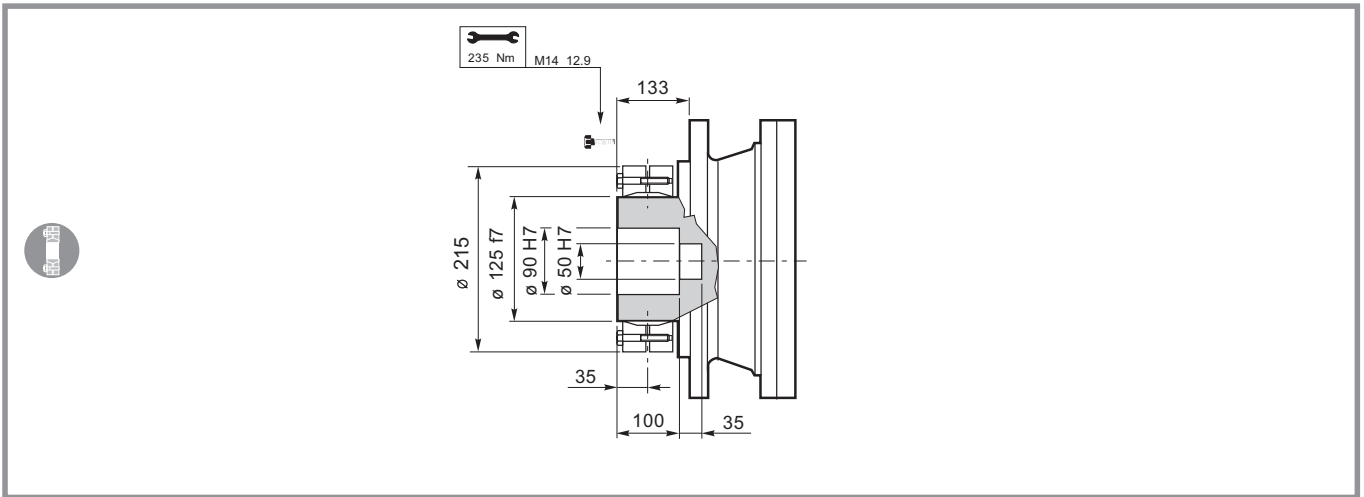







# 065

## S45CR1-S46C1

## S65CR1

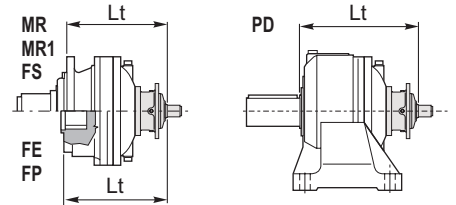
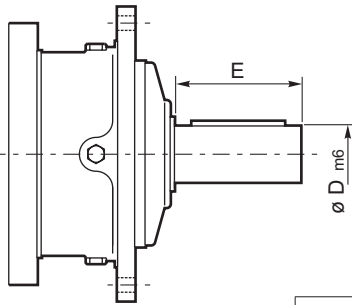

	D m6	E		Lt			
				MR-MR1-FS	FE	FP	PD
<b>S45 CR1</b>	65	105	<b>EM 1065</b>	386	334	278	426
			<b>ED 2065</b>	386	334	278	426
<b>S46 C1</b>	65	105	<b>EM 1065</b>	427	375	319	467
			<b>ED 2065</b>	318	375	319	467
<b>S65 CR1</b>	80	130	<b>EM 1065</b>	425	373	317	465

## SU2

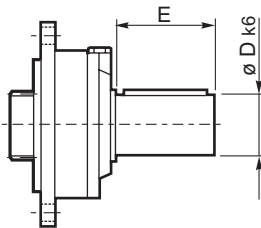

	D k6	E		Lt				
				MR MR1	FE	FS	FP	PD
<b>SU 2</b>	40	58	<b>EM 1065</b>	319	266	318	211	358
			<b>ED 2065</b>	383	331	383	275	423
			<b>ET 3065</b>	435	384	435	327	475
			<b>EQ 4065</b>	475	423	462	354	515

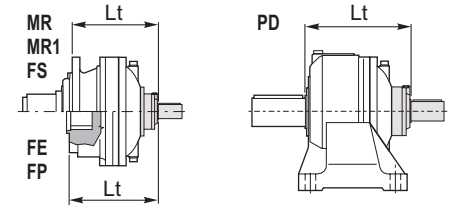

## ⑥ 48.82

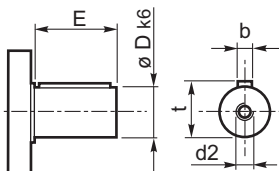

	D	E		Lt	
				MR-MR1-FS-FE-FP-PDA	
<b>48.82</b>	48	82	<b>EC 2065</b>	280	
			<b>EC 3065</b>	280	

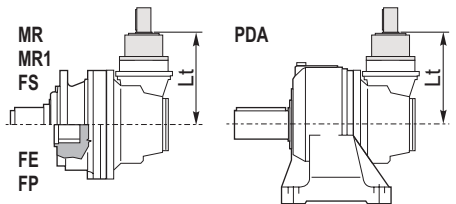

## FL250-FL350-FL450 FL750 FL760-FL960

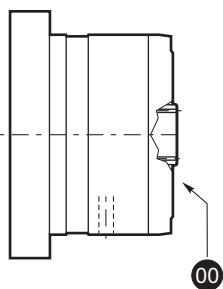

		Lt			
		MR-MR1-FS	FE	FP	PD-PDA
FL250 FL350 FL450	EM 1065	363	312	255	403
	ED 2065	416	365	308	456
	EC 2065	280	280	280	280
	EC 2065*	377	377	377	377
	EC 3065*	377	377	377	377
FL750	EM 1065	376	326	268	416
	ED 2065	429	378	321	469
FL760-FL960	EM 1065	—	339	—	—

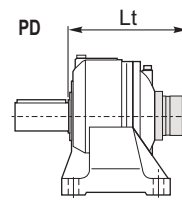
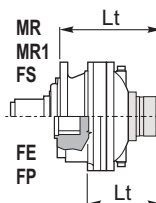

**FL620/10  
FL635/10**

**FL620U-FL635U**

SAE A-AA  
Shaft FE

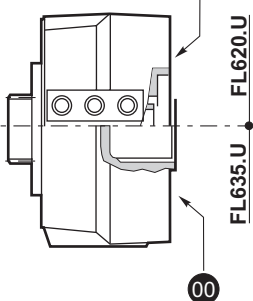

		Lt					
		MR-MR1	FS	FE	FP	PD	
FL620/U	EM 1065	363.5	362.5	310.5	255.5	402.5	
	ED 2065	427.5	427.5	375.5	319.5	467.5	
	ET 3065	479.5	479.5	428.5	371.5	519.5	
	EQ 4065	519.5	506.5	467.5	398.5	559.5	
	EC 2065	324.5	324.5	324.5	324.5	324.5	
	EC 2065*	330.5	330.5	330.5	330.5	330.5	
	EC 3065	324.5	324.5	324.5	324.5	324.5	
	EC 3065*	330.5	330.5	330.5	330.5	330.5	
	FL635U	EM 1065	350	349	297	242	389
		ED 2065	414	414	362	306	454
ET 3065		466	466	415	358	506	
EQ 4065		506	493	454	385	546	
EC 2065		311	311	311	311	311	
EC 2065*		317	317	317	317	317	
EC 3065		311	311	311	311	311	
EC 3065*		317	317	317	317	317	
FL620/10		ET3 065	439	439	388	331	479
		EQ 4065	479	479	428.8	371	519
FL635/10	ET 3065	420	420	369	312	460	
	EQ 4065	460	460	408	352	500	

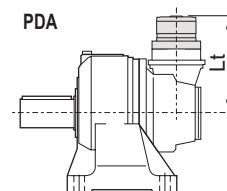
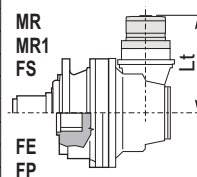

## IEC Motor

		Lt							
		IEC 63	IEC 71	IEC 80 90	IEC 100 112	IEC 132	IEC 160 180	IEC 200	IEC 225
EM 1065	MR-MR1-FS	278	280	285	286	353		394	424
EM1065	FE	226	228	233	234	301		342	372
EM 1065	FP								
ED 2065	MR-MR1-FS	343	345	350	351	418	449	459	490
ED 2065	FE	291	293	298	299	366	397	407	438
ED 2065	FP								
ET 3065	MR-MR1-FS	395	397	402	403	470			
ET 3065	FE	344	346	351	352	419			
ET 3065	FP								
EQ 4065	MR-MR1-FS	435	437	442	443	510			
EQ 4065	FE	383	385	390	391	458			
EQ 4065	FP								
PD 1065	PD	318	320	325	326	393	424	434	508
PD 2065	PD	383	385	390	391	458	489	490	530
PD 3065	PD	435	437	442	443	510	541		
PD 4065	PD	475	477	482	483				
EC 2065	MR-MR1-FE-FS-FP-PDA	240	242	247	248	315	346		
EC 2065*	MR-MR1-FE-FS-FP-PDA	246	248	253	254	321	352		
EC 3065	MR-MR1-FE-FS-FP-PDA	240	242	247	248	315	346		
EC 3065*	MR-MR1-FE-FS-FP-PDA	246	248	253	254	321	352		
EC 4065	MR-MR1-FE-FS-FP-PDA	151	151	151	151	238			
EC 4065*	MR-MR1-FE-FS-FP-PDA	151	151	151	151	238			

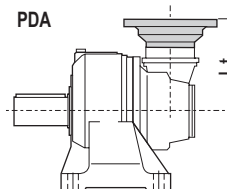
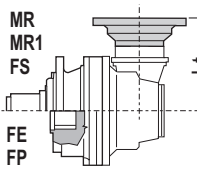
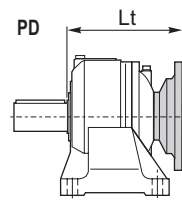
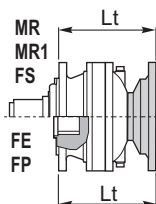

\* bg





**Flangia ruota**  
Driving flange  
Radnabenflansch  
Flasque de roue  
Brida de la rueda  
Flange de roda

## FR 065

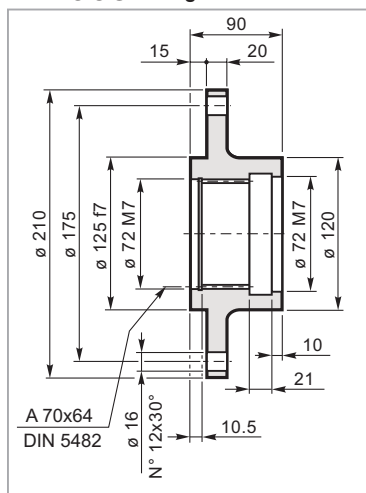

Mat. C40 UNI EN 10083  
Code: 3702031800



**Manicotto scanalato**  
Splined bush  
Keilmuffe  
Manchon cannelée  
Manguito acanalado  
Luva ranhurada

## MS 065

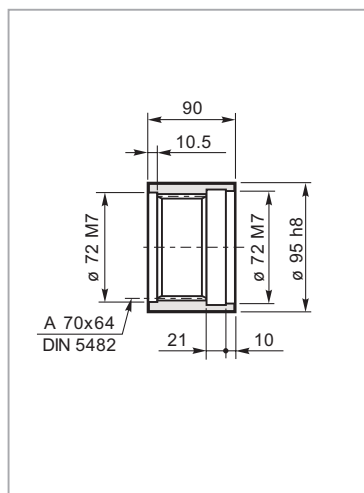

Mat. 39NiCrMo3 UNI EN 10083  
Code: 39102440600



**Pignoni**  
Pinion  
Ritzel  
Pignon  
Piñones  
Pinhões

## IR 065

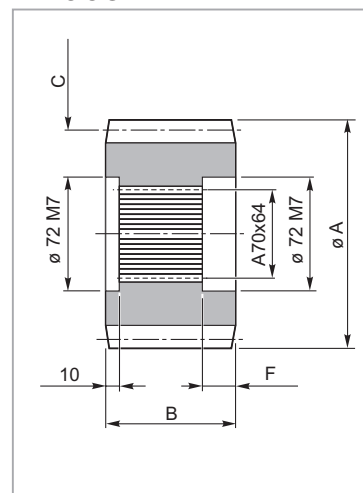

code	A	B	C	F
335.0463.0600	136	3.543	M=8 Z=15 —	31
335.2063.0600	160	3.543	M=10 Z=13 X=0.5	31
335.3033.0600	165	3.543	M=10 Z=13 X=0.95	31
335.3533.0600	149	3.543	M=10 Z=12 X=0.5	31



**Rondella di fermo**  
Shaft cover  
Gegenscheibe  
Rondelle frein  
Arandela de bloqueo  
Amuela de encosto

## RDF 065

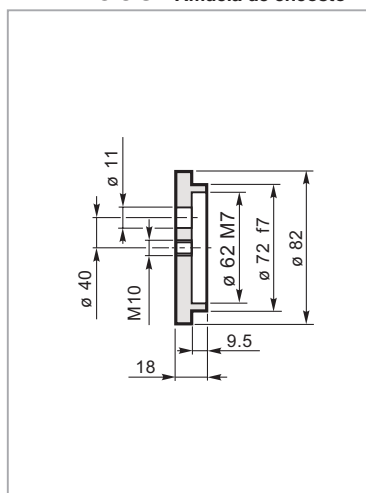

Mat. C40 UNI EN 10083  
Code: 37201440800



**Barra scanalata**  
Splined bar  
Zugspindel  
Barre cannelée  
Barra acanalada  
Barra ranhurada

## BS 065

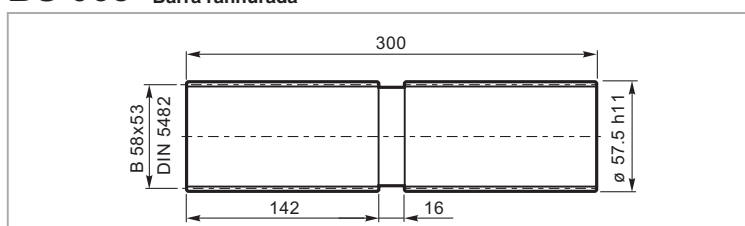

Mat. 39NiCrMo3 UNI EN 10083  
Code: 39126930100

Carichi radiali sugli alberi uscita / Radial loads on output shafts  
 Radiallasten auf de Abtriebswellen / Charges radiales sur les arbres de sortie  
 Cargas sobre los ejes de salida / Cargas radiais nos eixos de saida

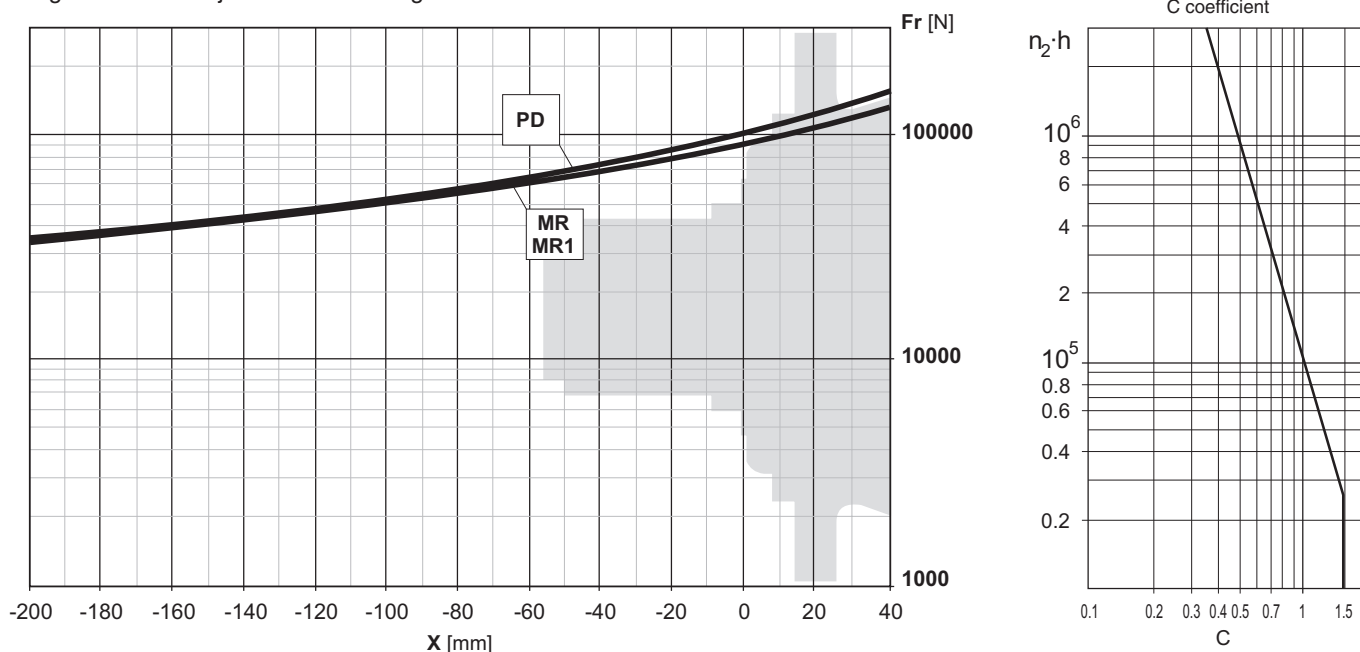

Carichi assiali / Axial loads / Axialkräfte / Charges axiales / Cargas axiales / Forças axiais

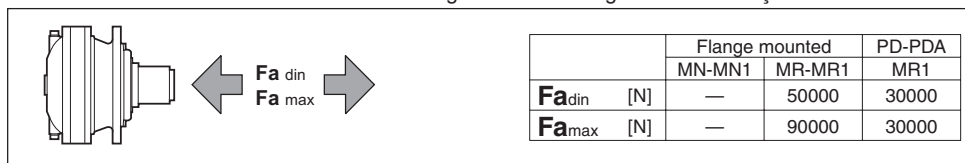

Carichi radiali sugli alberi entrata / Radial loads on input shafts  
 Radiallasten auf de Antriebswellen / Charges radiales sur les arbres d'entrée  
 Cargas sobre los ejes de entrada / Cargas radiais nos eixos de entrada

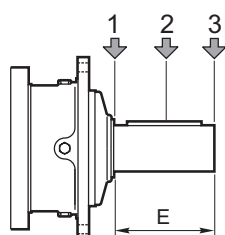

Type	E	$Fr$ [N]					
		$n_1 \cdot h = 10^7$			$n_1 \cdot h = 10^8$		
		1	2	3	1	2	3
S45 CR1	105	10000	6000	4000	5000	3000	2000
S46 C1	105	14000	8800	6400	7000	4400	3200
S65 CR1	130	23800	15500	9600	11900	7800	4800

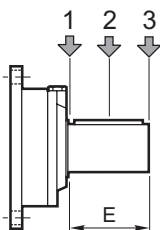

Type	E	$Fr$ [N]					
		$n_1 \cdot h = 10^7$			$n_1 \cdot h = 10^8$		
		1	2	3	1	2	3
SU2	58	3000	2000	1500	1400	1000	700

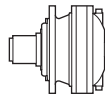

$i_{\text{eff}}$	1500			1000			500			$T_{2\text{max}}$ [Nm]	$P_T$ [kW]	
	$n_2$ [rpm]	$T_2$ [Nm]	$P_2$ [kW]	$n_2$ [rpm]	$T_2$ [Nm]	$P_2$ [kW]	$n_2$ [rpm]	$T_2$ [Nm]	$P_2$ [kW]			
<b>ED 2067</b>												
12.25	122	3264	41.9	82	3686	31.5	40.8	4538	19.4	9800	18	
14.46	104	3430	37.3	69	3874	28.1	34.6	4769	17.3	9800		
15.16	99	3417	35.4	66	3859	26.7	33.0	4751	16.4	10000		
18.10	83	3669	31.9	55	4144	24.0	27.6	5102	14.8	10000		
21.00	71	3837	28.7	47.6	4333	21.6	23.8	5335	13.3	10000		
22.39	67	3841	27.0	44.7	4338	20.3	22.3	5340	12.5	10000		
25.38	59	4061	25.1	39.4	4586	18.9	19.7	5646	11.7	10000		
27.99	54	4179	23.5	35.7	4720	17.7	17.9	5811	10.9	10000		
31.39	47.8	4251	21.3	31.9	4801	16.0	15.9	5885	9.8	10000		
36.25	41.4	4350	18.9	27.6	4913	14.2	13.8	5575	8.1	10000		
43.50	34.5	3971	14.3	23.0	4137	10.0	11.5	4422	5.3	10000		
<b>ET 3067</b>												
50.59	29.6	4995	15.5	19.8	5641	11.7	9.9	6945	7.2	10000		14
55.80	26.9	5141	14.5	17.9	5806	10.9	9.0	6373	6.0	10000		
63.33	23.7	5343	13.3	15.8	6034	10.0	7.9	7366	6.1	10000		
73.50	20.4	5587	11.9	13.6	6310	9.0	6.8	7597	5.4	10000		
78.35	19.1	5593	11.2	12.8	6004	8.0	6.4	6600	4.4	10000		
88.81	16.9	5914	10.5	11.3	6678	7.9	5.6	7898	4.7	10000		
104.8	14.3	6215	9.3	9.5	7018	7.0	4.8	8169	4.1	10000		
109.9	13.7	5968	8.5	9.1	6188	5.9	4.6	7082	3.4	10000		
126.0	11.9	6568	8.2	7.9	7358	6.1	4.0	8478	3.5	10000		
144.7	10.4	6227	6.8	6.9	6734	4.9	3.5	7766	2.8	10000		
162.3	9.2	6180	6.0	6.2	6649	4.3	3.1	7668	2.5	10000		
188.4	8.0	6297	5.3	5.3	6860	3.8	2.7	7901	2.2	10000		
202.9	7.4	6639	5.1	4.9	7224	3.7	2.5	8308	2.1	10000		
227.6	6.6	6556	4.5	4.4	7134	3.3	2.2	8205	1.9	10000		
262.8	5.7	6183	3.7	3.8	6733	2.7	1.9	7753	1.5	10000		
315.4	4.8	4894	2.4	3.2	5343	1.8	1.6	6175	1.0	10000		

**1500**  
HOURS LIFE

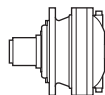

**067**

$i_{eff}$	1500			1000			500			$T_{2max}$ [Nm]	$P_T$ [kW]
	$n_2$ [rpm]	$T_2$ [Nm]	$P_2$ [kW]	$n_2$ [rpm]	$T_2$ [Nm]	$P_2$ [kW]	$n_2$ [rpm]	$T_2$ [Nm]	$P_2$ [kW]		

**ED 2067**

12.25	122	5767	74	82	6513	56	40.8	7713	33.0	9800	
14.46	104	6060	66	69	6844	49.6	34.6	7988	28.9	9800	
15.16	99	5816	60	66	6071	42.0	33.0	6924	23.9	10000	
18.10	83	6483	56	55	7223	41.8	27.6	8369	24.2	10000	
21.00	71	6779	51	47.6	7462	37.2	23.8	8628	21.5	10000	
22.39	67	6061	42.5	44.7	6484	30.3	22.3	7514	17.6	10000	18
25.38	59	6838	42.3	39.4	7271	30.0	19.7	7934	16.4	10000	
27.99	54	6458	36.3	35.7	7057	26.4	17.9	8149	15.2	10000	
31.39	47.8	6388	32.0	31.9	6976	23.3	15.9	8051	13.4	10000	
36.25	41.4	6034	26.2	27.6	6590	19.0	13.8	7610	11.0	10000	
43.50	34.5	4777	17.3	23.0	5229	12.6	11.5	6061	7.3	10000	

**ET 3067**

50.59	29.6	8249	25.6	19.8	8959	18.5	9.9	10267	10.6	10000	
55.80	26.9	7494	21.1	17.9	8144	15.3	9.0	9342	8.8	10000	
63.33	23.7	8637	21.4	15.8	9369	15.5	7.9	10719	8.9	10000	
73.50	20.4	8902	19.0	13.6	9648	13.7	6.8	11027	7.9	10000	
78.35	19.1	7756	15.6	12.8	8416	11.3	6.4	9636	6.4	10000	
88.81	16.9	9245	16.4	11.3	10011	11.8	5.6	11428	6.7	10000	
104.8	14.3	9552	14.3	9.5	10337	10.3	4.8	11788	5.9	10000	
109.9	13.7	8304	11.9	9.1	8996	8.6	4.6	10278	4.9	10000	
126.0	11.9	9882	12.3	7.9	10687	8.9	4.0	12199	5.1	10000	14
144.7	10.4	9080	9.9	6.9	9821	7.1	3.5	11195	4.1	10000	
162.3	9.2	8970	8.7	6.2	9702	6.3	3.1	11058	3.6	10000	
188.4	8.0	9233	7.7	5.3	9981	5.6	2.7	11369	3.2	10000	
202.9	7.4	9669	7.5	4.9	10474	5.4	2.5	11918	3.1	10000	
227.6	6.6	9577	6.6	4.4	10346	4.8	2.2	11773	2.7	10000	
262.8	5.7	9061	5.4	3.8	9793	3.9	1.9	11151	2.2	10000	
315.4	4.8	7244	3.6	3.2	7842	2.6	1.6	8951	1.5	10000	

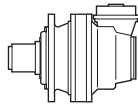

$i_{\text{eff}}$	1500			1000			500			$T_{2\text{max}}$ [Nm]	$P_T$ [kW]
	$n_2$ [rpm]	$T_2$ [Nm]	$P_2$ [kW]	$n_2$ [rpm]	$T_2$ [Nm]	$P_2$ [kW]	$n_2$ [rpm]	$T_2$ [Nm]	$P_2$ [kW]		

**EC 3067 - PDA 3067**

40.53	37.0	4671	18.1	24.7	5275	13.6	12.3	6131	7.9	10000
43.37	34.6	4769	17.3	23.1	5386	13.0	11.5	6631	8.0	10000
47.83	31.4	4908	16.1	20.9	5543	12.1	10.5	6222	6.8	10000
56.60	26.5	5166	14.3	17.7	5834	10.8	8.8	7183	6.6	10000
62.42	24.0	5317	13.4	16.0	5987	10.0	8.0	6527	5.5	10000
70.02	21.4	5408	12.1	14.3	5944	8.9	7.1	6445	4.8	10000
83.60	17.9	5807	10.9	12.0	6558	8.2	6.0	7801	4.9	10000
92.20	16.3	5977	10.2	10.8	6202	7.0	5.4	7083	4.0	10000
97.02	15.5	6072	9.8	10.3	6858	7.4	5.2	8042	4.3	10000
117.2	12.8	6427	8.6	8.5	7211	6.4	4.3	7758	3.5	10000
120.0	12.5	6016	7.9	8.3	6237	5.4	4.2	7212	3.1	10000
145.0	10.3	6118	6.6	6.9	6493	4.7	3.4	7496	2.7	10000
167.5	9.0	5797	5.4	6.0	6124	3.8	3.0	7078	2.2	10000
201.0	7.5	4603	3.6	5.0	4846	2.5	2.5	5624	1.5	10000

11

Tutti i rapporti evidenziati (es. 40.53) hanno dimensioni particolari della coppia conica in certe versioni; vedere tavole dimensionali.

All ratios grey highlighted (ex. 40.53) have specific dimensions of the bevel gear set in some versions; see dimensional tables.

Alle mit (es. 40.53) gekennzeichneten Übersetzungen haben in bestimmten Versionen besondere Dimensionen des Kegelradtriebs. Siehe auch Dimensionstabellen.

Les rapports repérés par (es. 40.53) ont des dimensions de couple conique particulières. Voir les tableaux dimensionnels.

Todas las relaciones indicadas con (es. 40.53) tienen dimensiones particulares del par cónico según las versiones; ver las tablas de dimensión.

As relações marcadas com (es. 40.53) têm dimensões particulares da engrenagem cônica em certas versões; vide tabelas dimensionais.



129

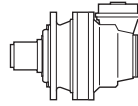

$i_{eff}$	1500			1000			500			$T_{2max}$ [Nm]	$P_T$ [kW]
	$n_2$ [rpm]	$T_2$ [Nm]	$P_2$ [kW]	$n_2$ [rpm]	$T_2$ [Nm]	$P_2$ [kW]	$n_2$ [rpm]	$T_2$ [Nm]	$P_2$ [kW]		

**EC 3067 - PDA 3067**

40.53	37.0	7004	27.1	24.7	7629	19.7	12.3	8775	11.3	10000
43.37	34.6	7988	28.9	23.1	8684	21.0	11.5	9965	12.0	10000
47.83	31.4	7255	23.8	20.9	7893	17.3	10.5	9065	9.9	10000
56.60	26.5	8441	23.4	17.7	9162	17.0	8.8	10491	9.7	10000
62.42	24.0	7670	19.3	16.0	8330	14.0	8.0	9547	8.0	10000
70.02	21.4	7579	17.0	14.3	8230	12.3	7.1	9430	7.1	10000
83.60	17.9	9134	17.2	12.0	9894	12.4	6.0	11299	7.1	10000
92.20	16.3	8304	14.1	10.8	9000	10.2	5.4	10286	5.8	10000
97.02	15.5	9408	15.2	10.3	10062	10.9	5.2	11619	6.3	10000
117.2	12.8	8323	11.2	8.5	8682	7.8	4.3	10181	4.5	10000
120.0	12.5	8452	11.1	8.3	9153	8.0	4.2	10451	4.6	10000
145.0	10.3	8774	9.5	6.9	9494	6.9	3.4	10829	3.9	10000
167.5	9.0	8297	7.8	6.0	8982	5.6	3.0	10252	3.2	10000
201.0	7.5	6621	5.2	5.0	7180	3.7	2.5	8217	2.1	10000

11

Tutti i rapporti evidenziati (es. 40.53) hanno dimensioni particolari della coppia conica in certe versioni; vedere tavole dimensionali.

All ratios grey highlighted (ex. 40.53) have specific dimensions of the bevel gear set in some versions; see dimensional tables.

Alle mit (es. 40.53) gekennzeichneten Übersetzungen haben in bestimmten Versionen besondere Dimensionen des Kegelradtriebs. Siehe auch Dimensionstabellen.

Les rapports repérés par (es. 40.53) ont des dimensions de couple conique particulières. Voir les tableaux dimensionnels.

Todas las relaciones indicadas con (es. 40.53) tienen dimensiones particulares del par cónico según las versiones; ver las tablas de dimensión.

As relações marcadas com (es. 40.53) têm dimensões particulares da engrenagem cônica em certas versões; vide tabelas dimensionais.





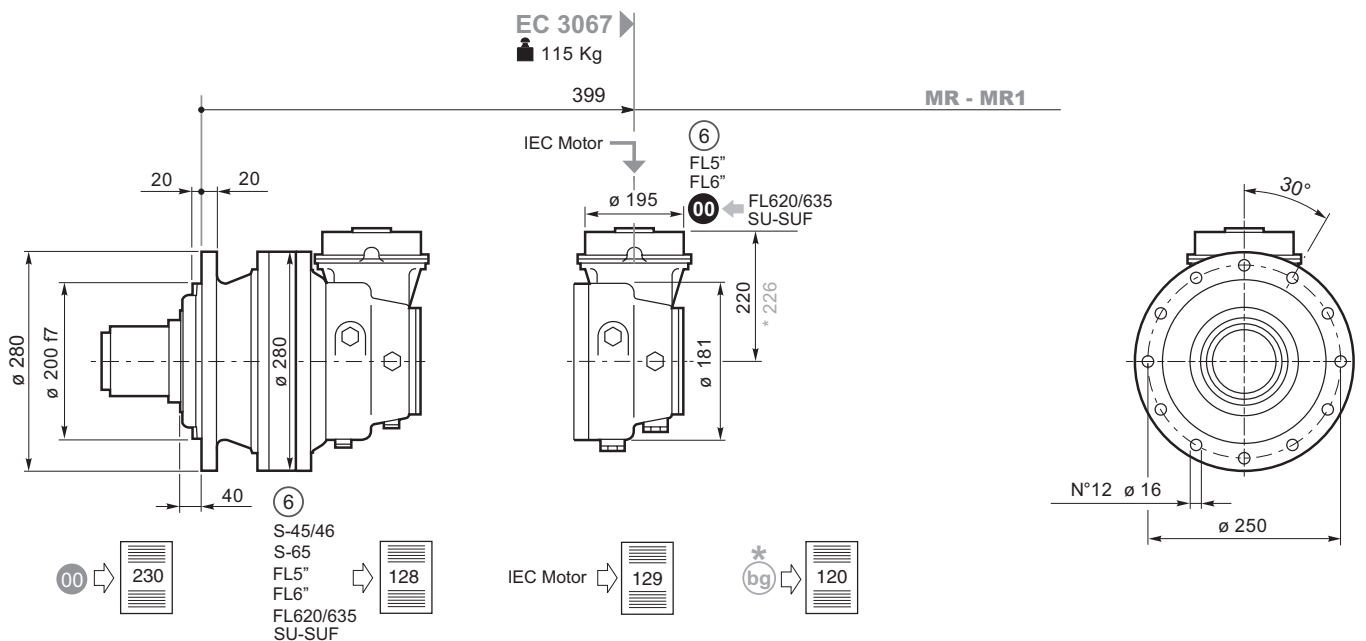
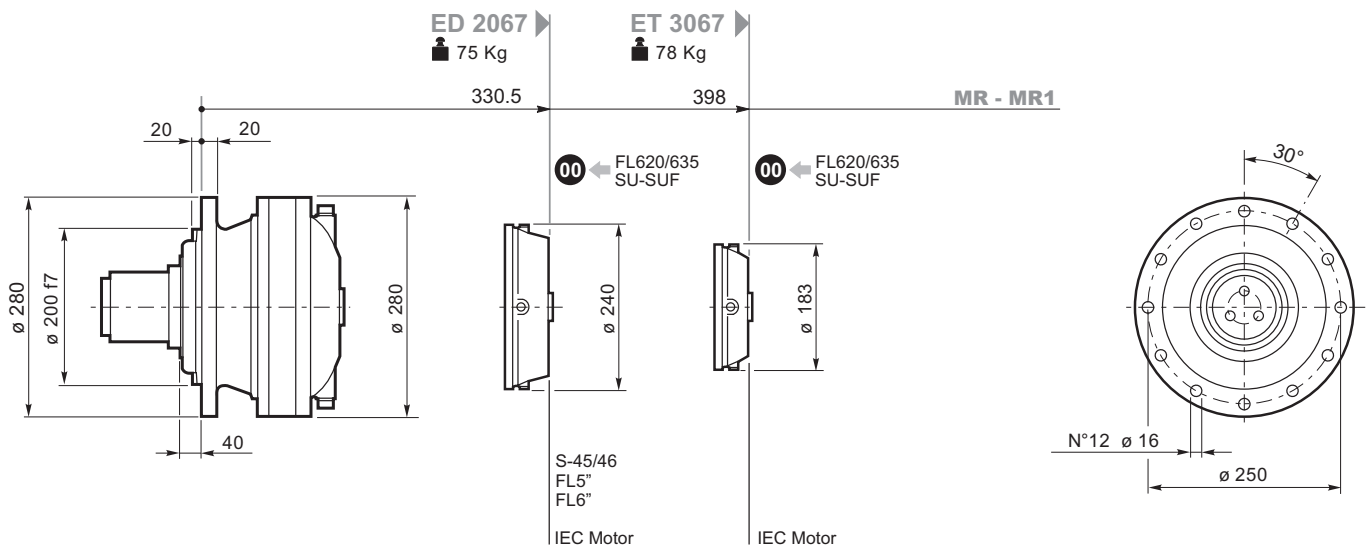
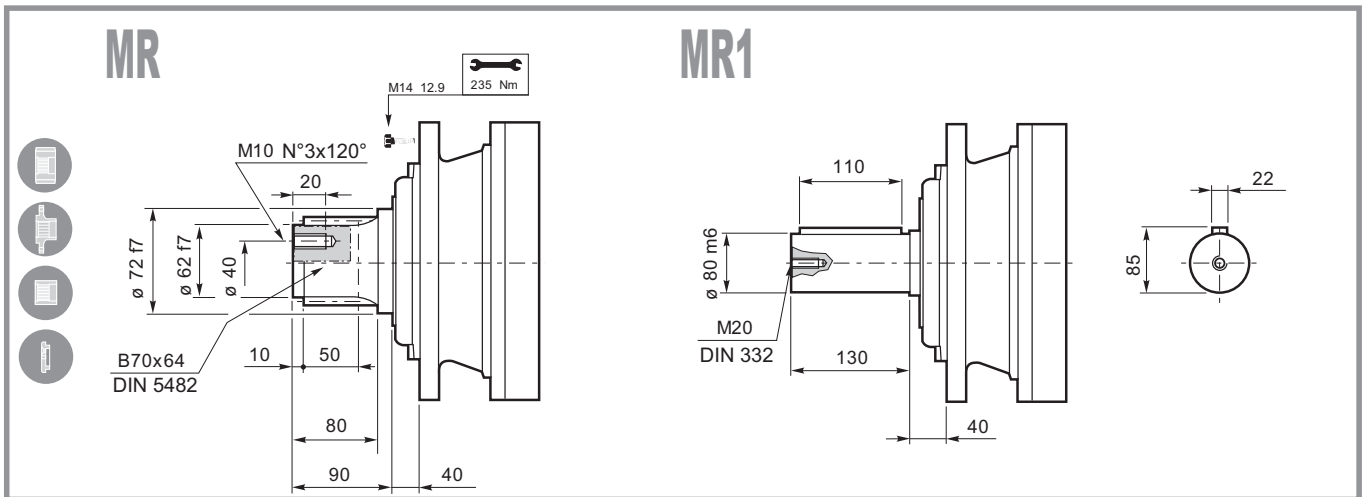

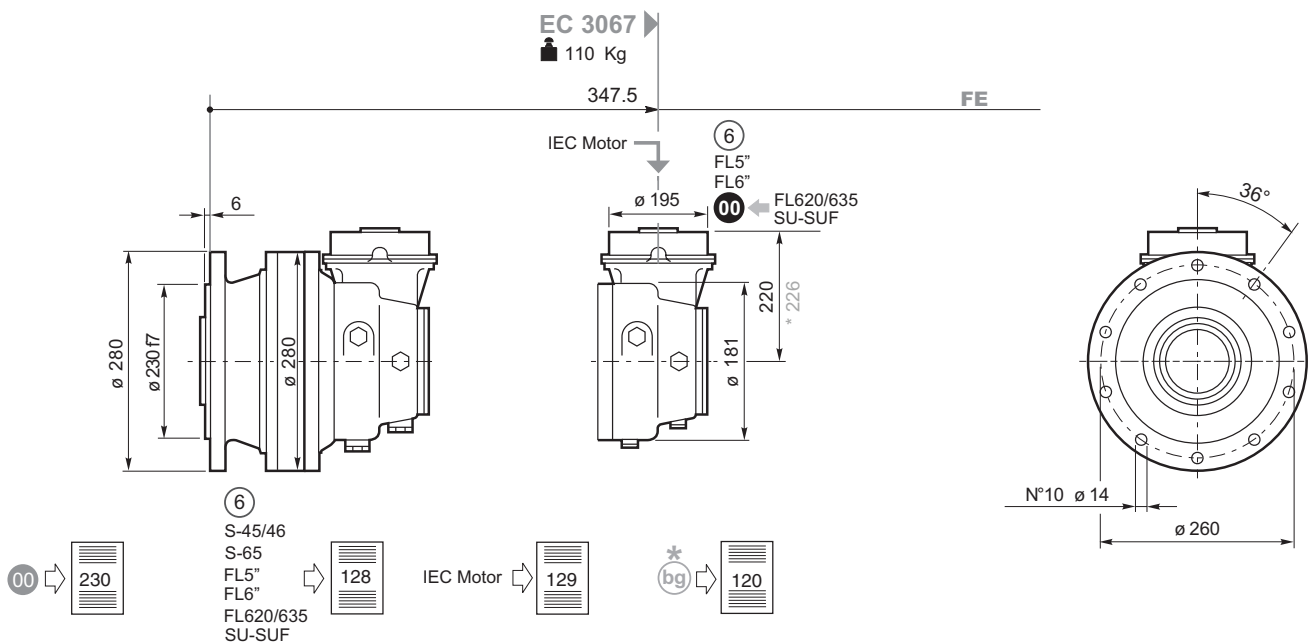
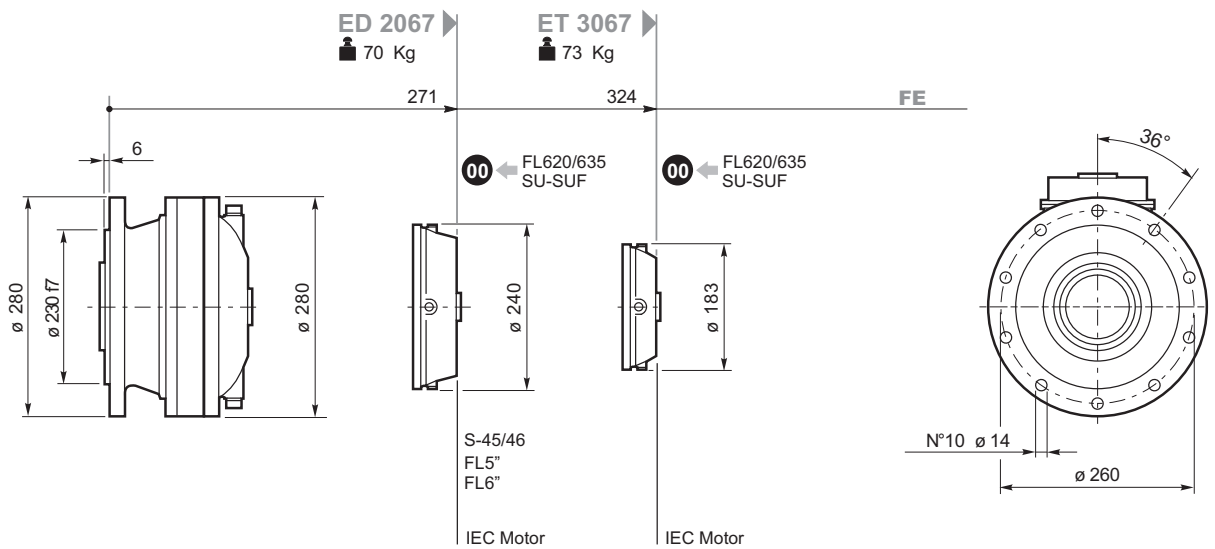
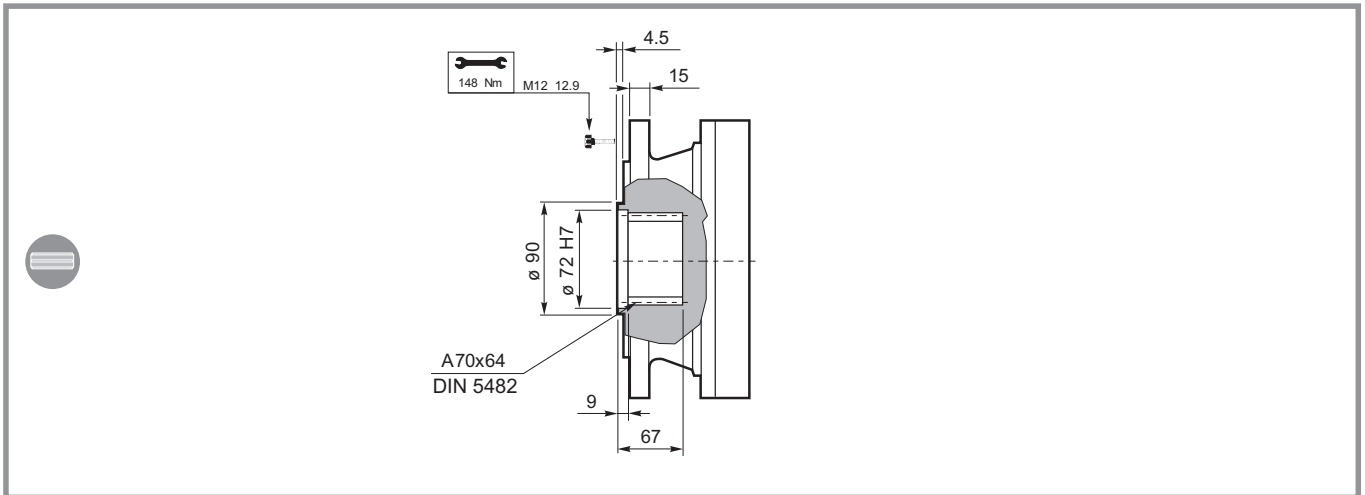

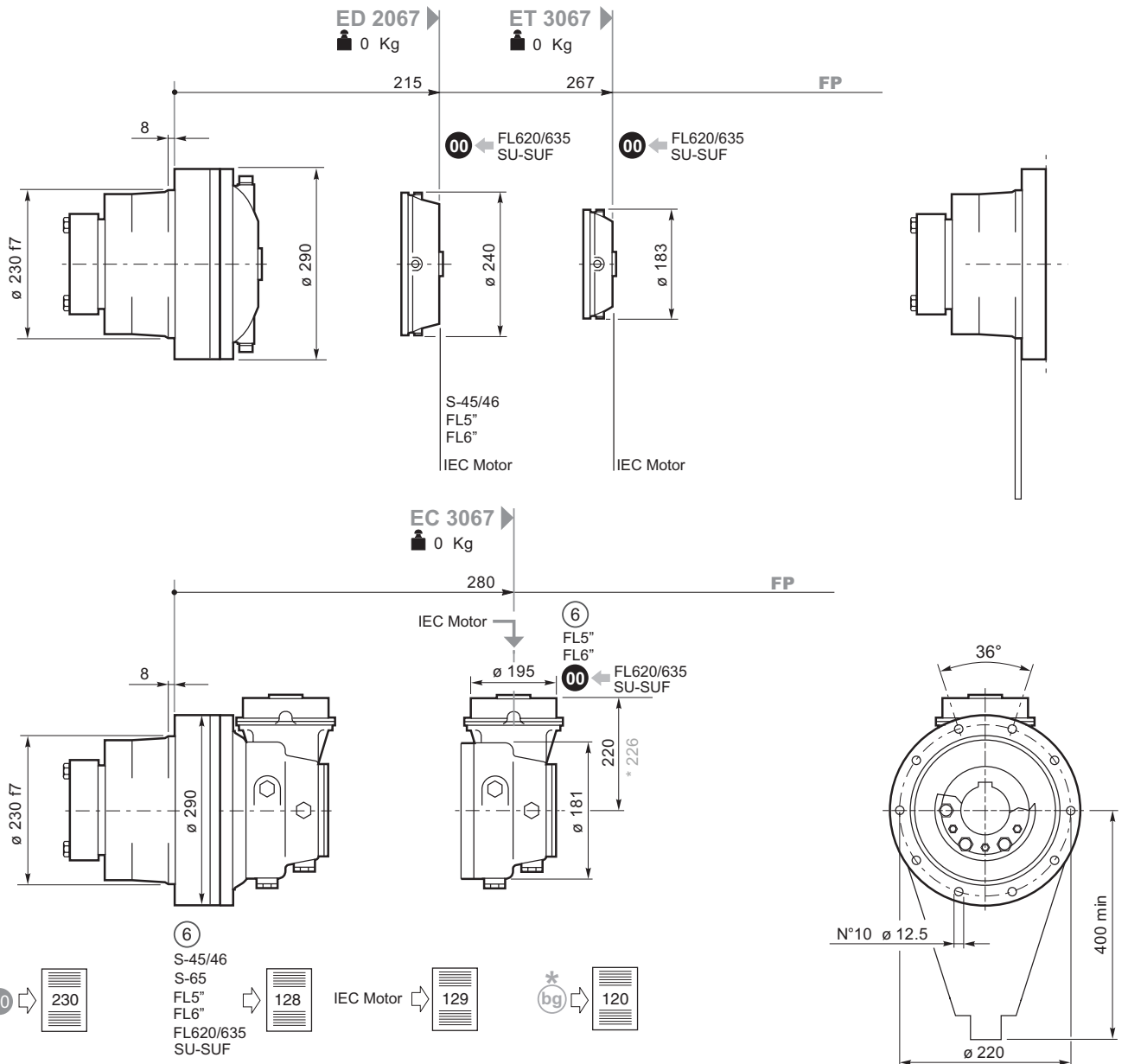
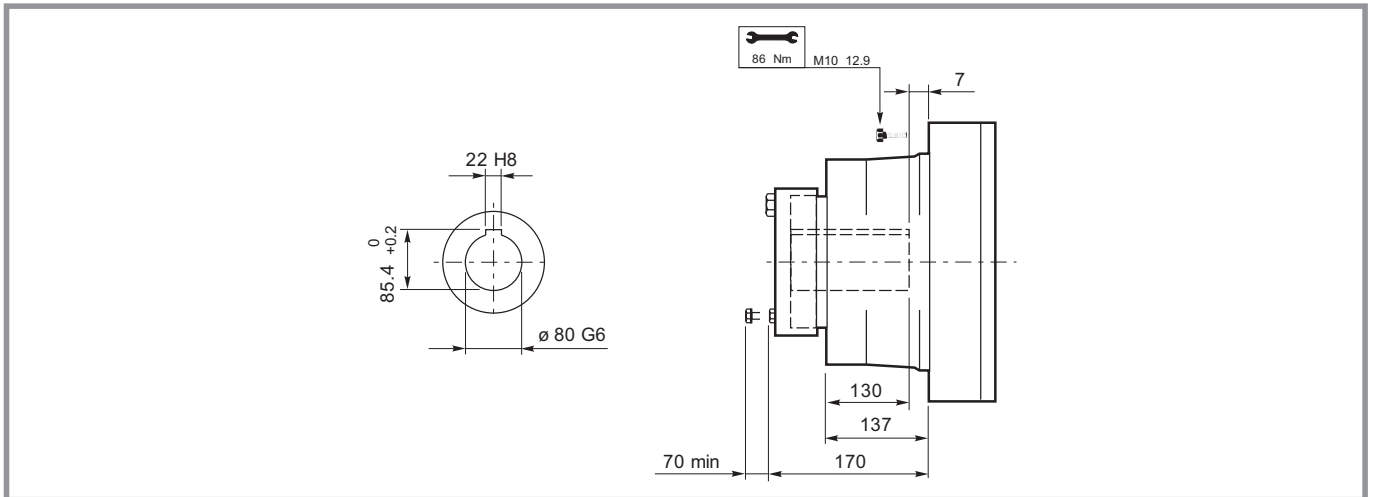

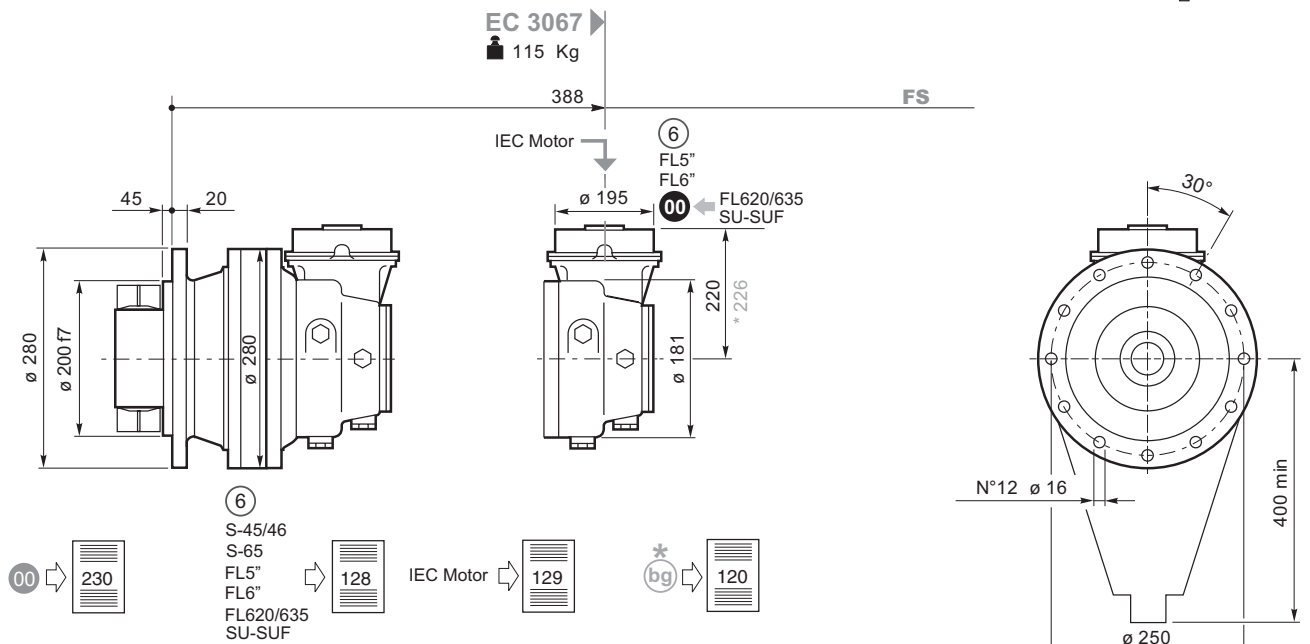
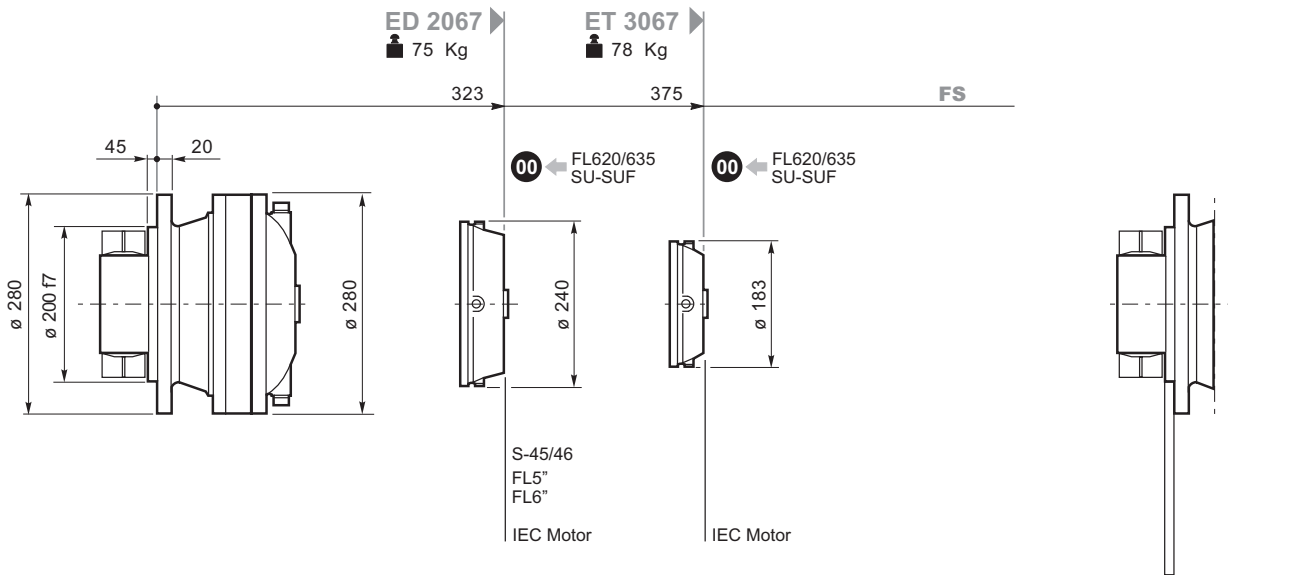
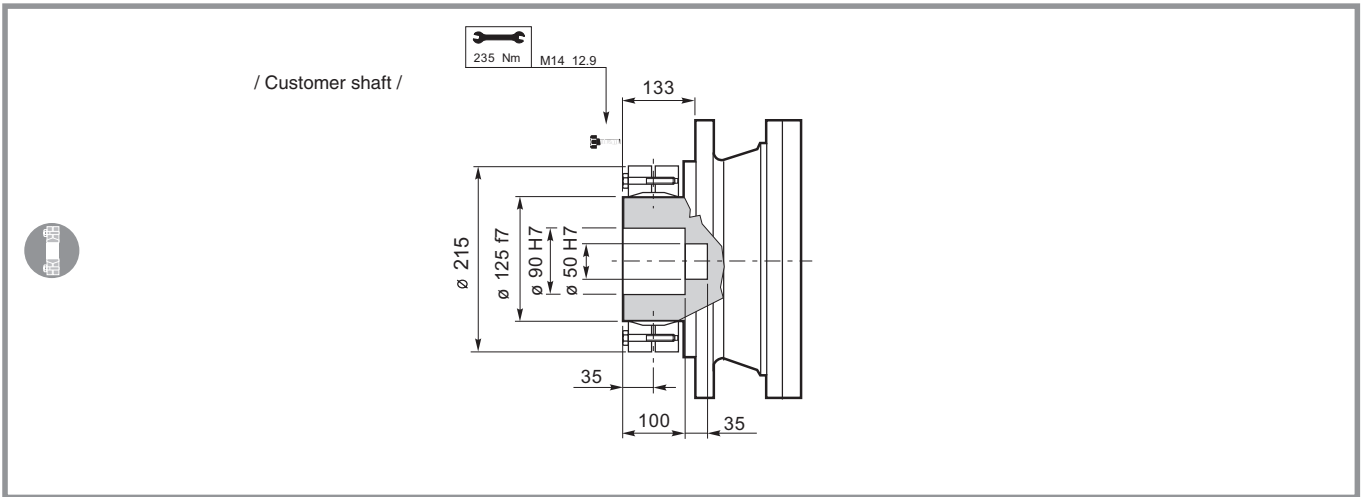

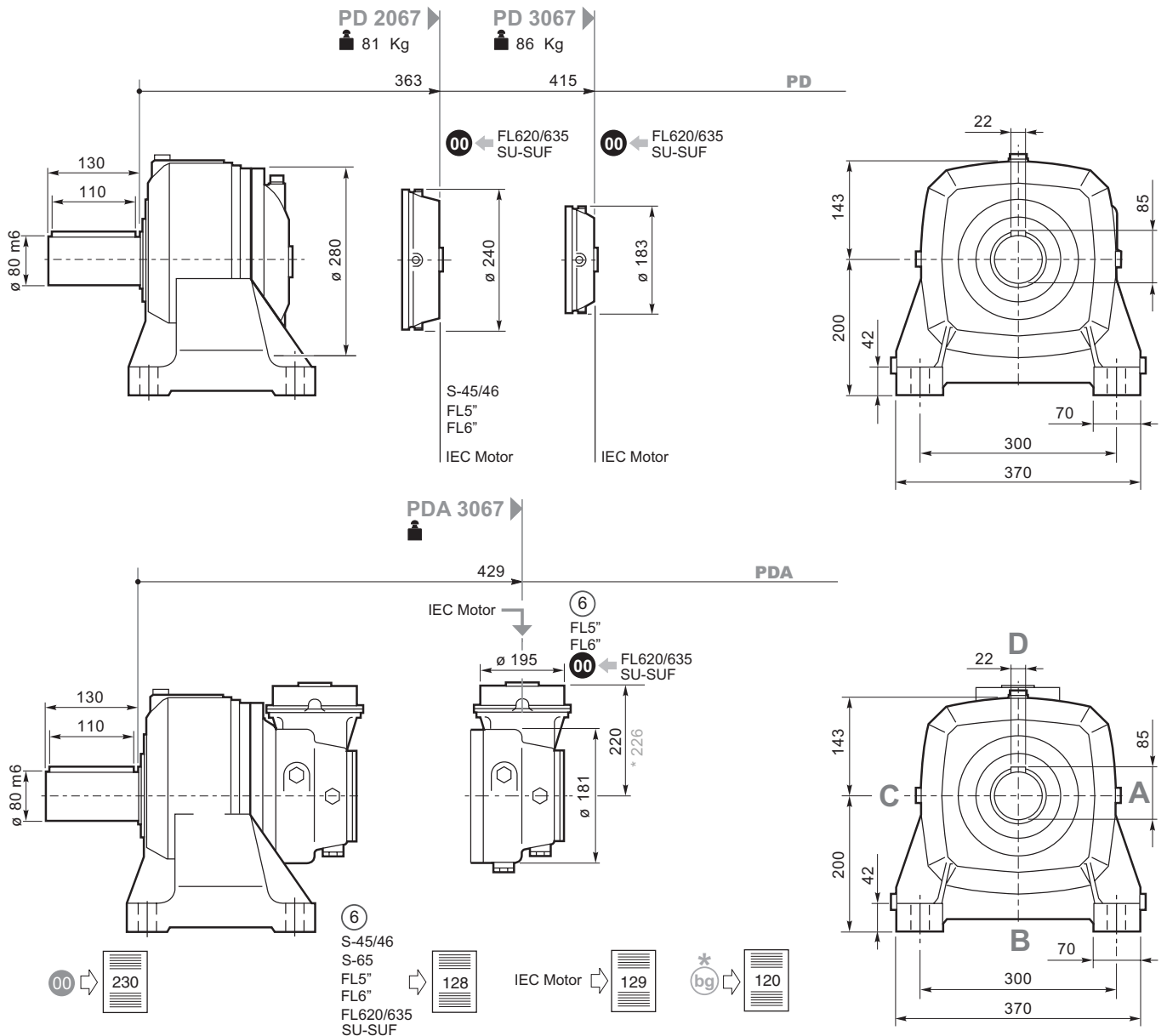
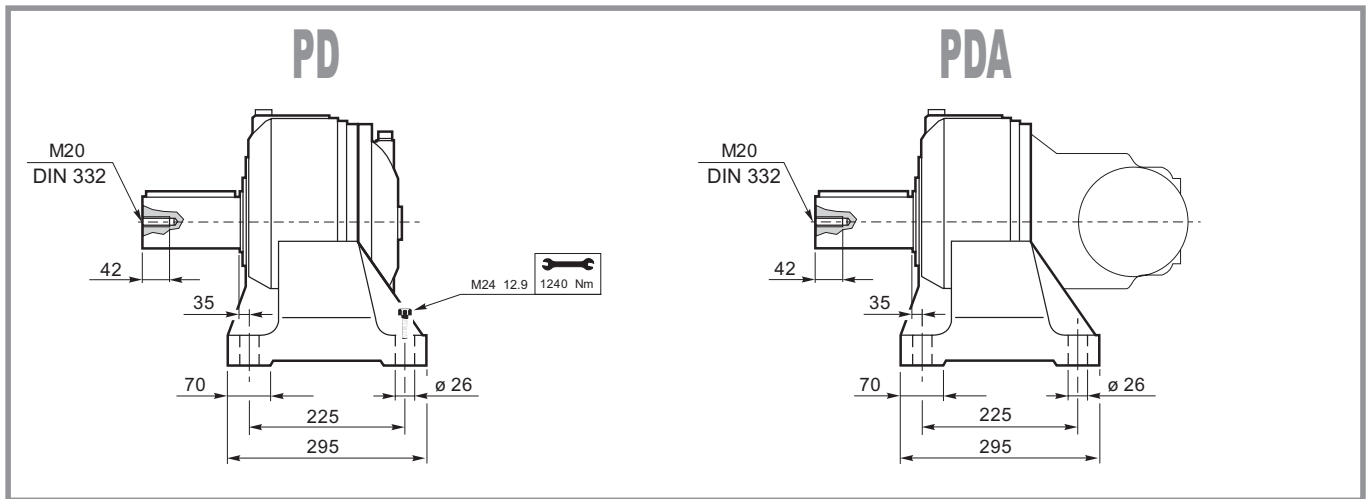



## S45CR1-S46C1

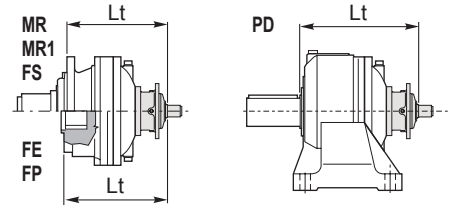
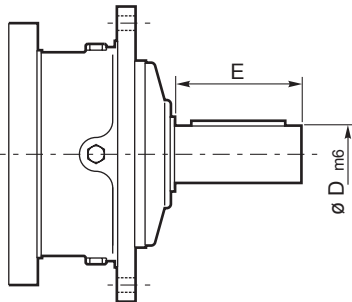

	D m6	E		Lt			
				MR-MR1-FS	FE	FP	PD
<b>S45 CR1</b>	65	105	<b>ED 2067</b>	394	342		434
			<b>ET 3067</b>	461	409		501
<b>S46 C1</b>	65	105	<b>ED 2067</b>	435	383		475
			<b>ET 3067</b>	502	455		542

## SU2

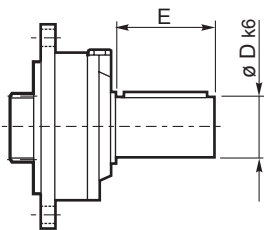

	D k6	E		Lt				
				MR MR1	FE	FS	FP	PD
<b>SU 2</b>	40	58	<b>ED 2067</b>	383	331	383	275	423
			<b>ET 3067</b>	435	384	435	327	475

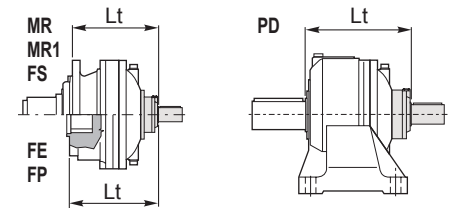

## ⑥ 48.82

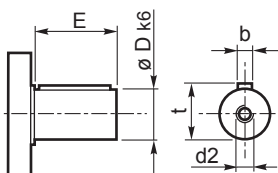

	D	E		Lt
				MR-MR1-FS-FE-FP-PDA
<b>48.82</b>	48	82	<b>EC 3067</b>	280

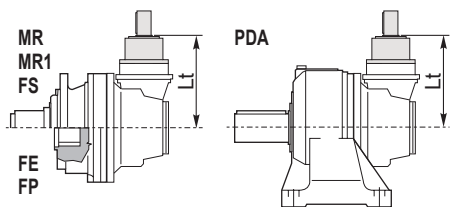

## FL250-FL350-FL450 FL750

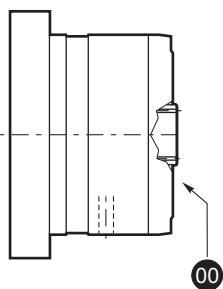

**FL620/10  
FL635/10**

**FL620U-FL635U**

SAE A-AA  
Shaft FE

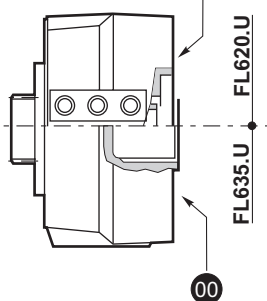

		Lt			
		MR-MR1-FS	FE	FP	PD-PDA
FL250	ED 2067	371	319	315	411
	ET 3067	438	386	382	478
FL350	EC 3067	280	280	280	280
FL450	EC 3067*	377	377	377	377
FL750	ED 2067	384	332	328	424
	ET 3067	451	399	395	491

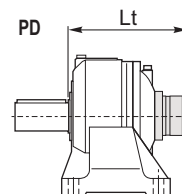
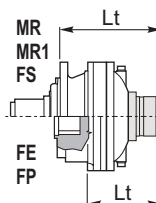

		Lt				
		MR-MR1	FS	FE	FP	PD
FL620/U	ED 2067	435	335	383	327	475
	ET 3067	293.5	502.5	451	395	542.5
	EC 3067	324.5	324.5	324.5	324.5	324.5
	EC 3067*	330.5	330.5	330.5	330.5	330.5
FL635U	ED 2067	445	321.5	369.5	313.5	461.5
	ET 3067	280	489	437.5	381.5	529
	EC 3067	311	311	311	311	311
	EC 3067*	317	317	317	317	317
FL620/10	ET 3067	462	462	450	394	502
FL635/10	ET 3067	443	443	421	365	473

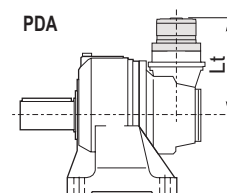
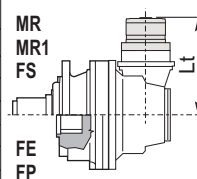

## IEC Motor

		Lt							
		IEC 63	IEC 71	IEC 80 90	IEC 100 112	IEC 132	IEC 160 180	IEC 200	IEC 225
ED 2067	MR-MR1-FS				359	425	457	467	497
ED 2067	FE				307	374	405	415	445
ED 2067	FP				303	369	401	411	441
ET 3067	MR-MR1-FS	418	420	425	426	493	524	534	564
ET 3067	FE	367	369	374	375	442	473	483	513
ET 3067	FP	362	364	369	370	437	468	478	508
PD 2067	PD				399	466	497	507	537
PD 3067	PD	458	460	465	466	533	564	574	604
EC 3067	MR-MR1-FE-FS-FP	240	242	247	248	315	346	357	
EC 3067*	MR-MR1-FE-FS-FP	246	248	253	254	321	352	363	
PDA3069	PDA	240	242	247	248	315	346	357	
PDA 3069*	PDA	246	248	253	254	321	352	363	

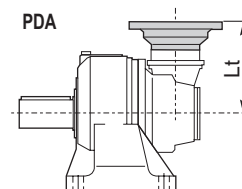
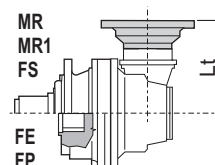
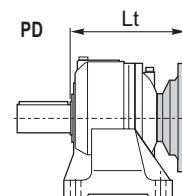
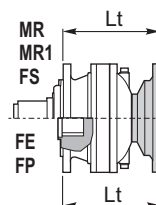

\* (bg) 120





**Flangia ruota**  
Driving flange  
Radnabenflansch  
Flasque de roue  
Brida de la rueda  
Flange de roda

## FR 065

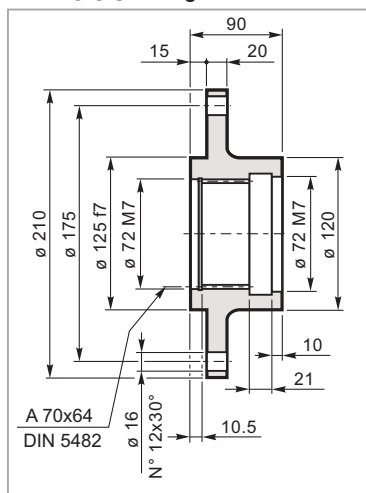

Mat. C40 UNI EN 10083  
Code: 3702031800



**Manicotto scanalato**  
Splined bush  
Keilmuffe  
Manchon cannelée  
Manguito acanalado  
Luva ranhurada

## MS 065

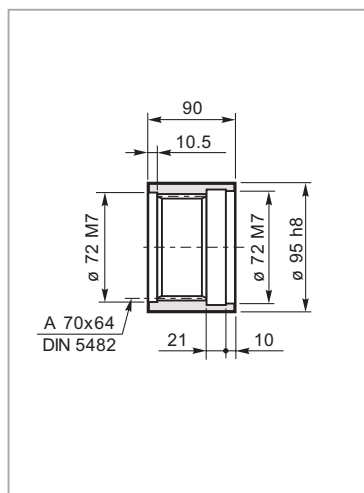

Mat. 39NiCrMo3 UNI EN 10083  
Code: 39102440600



**Pignoni**  
Pinion  
Ritzel  
Pignon  
Piñones  
Pinhões

## IR 065

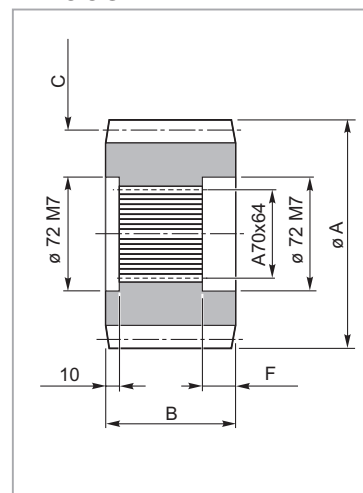

code	A	B	C	F
335.0463.0600	136	3.543	M=8 Z=15 —	31
335.2063.0600	160	3.543	M=10 Z=13 X=0.5	31
335.3033.0600	165	3.543	M=10 Z=13 X=0.95	31
335.3533.0600	149	3.543	M=10 Z=12 X=0.5	31



**Rondella di fermo**  
Shaft cover  
Gegenscheibe  
Rondelle frein  
Arandela de bloqueo  
Amuela de encosto

## RDF 065

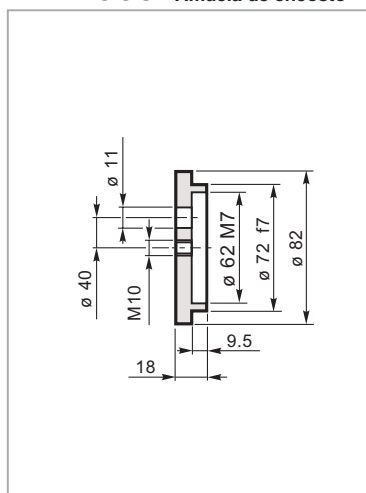

Mat. C40 UNI EN 10083  
Code: 37201440800



**Barra scanalata**  
Splined bar  
Zugspindel  
Barre cannelée  
Barra acanalada  
Barra ranhurada

## BS 065

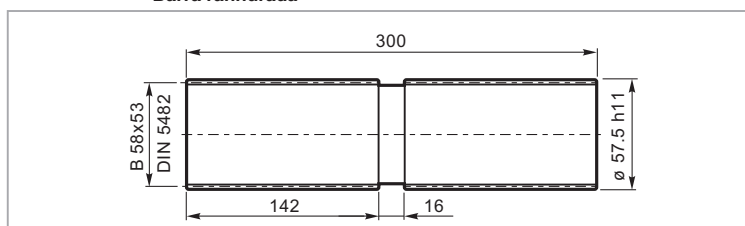

Mat. 39NiCrMo3 UNI EN 10083  
Code: 39126930100

Carichi radiali sugli alberi uscita / Radial loads on output shafts  
 Radiallasten auf de Abtriebswellen / Charges radiales sur les arbres de sortie  
 Cargas sobre los ejes de salida / Cargas radiais nos eixos de saida

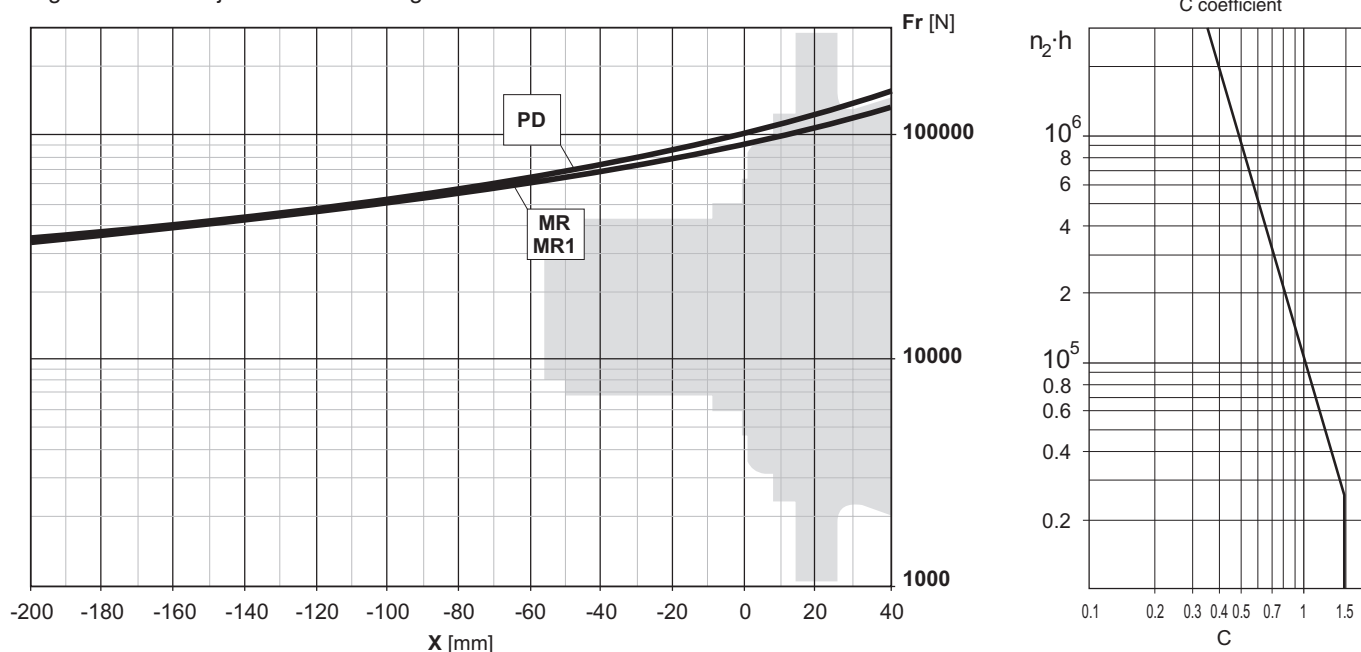

Carichi assiali / Axial loads / Axialkräfte / Charges axiales / Cargas axiales / Forças axiais

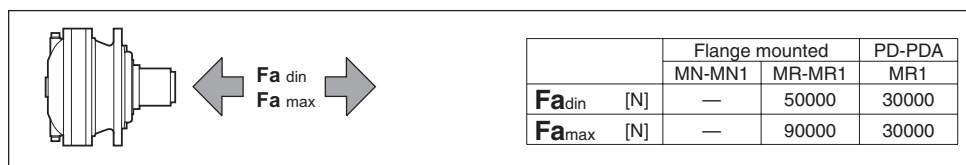

Carichi radiali sugli alberi entrata / Radial loads on input shafts  
 Radiallasten auf de Antriebswellen / Charges radiales sur les arbres d'entrée  
 Cargas sobre los ejes de entrada / Cargas radiais nos eixos de entrada

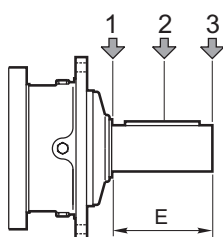

Type	E	$Fr$ [N]					
		$n_1 \cdot h = 10^7$			$n_1 \cdot h = 10^8$		
		1	2	3	1	2	3
S45 CR1	105	10000	6000	4000	5000	3000	2000
S46 C1	105	14000	8800	6400	7000	4400	3200
S65 CR1	130	23800	15500	9600	11900	7800	4800

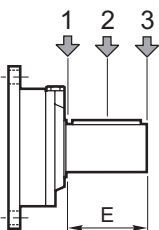

Type	E	$Fr$ [N]					
		$n_1 \cdot h = 10^7$			$n_1 \cdot h = 10^8$		
		1	2	3	1	2	3
SU2	58	3000	2000	1500	1400	1000	700

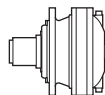

$i_{eff}$	1500			1000			500			$T_{2max}$ [Nm]	$P_T$ [kW]	
	$n_2$ [rpm]	$T_2$ [Nm]	$P_2$ [kW]	$n_2$ [rpm]	$T_2$ [Nm]	$P_2$ [kW]	$n_2$ [rpm]	$T_2$ [Nm]	$P_2$ [kW]			
<b>EM 1090</b>												
4.08	368	2936	113	245	3316	85	123	4082	52	15000	40	
5.05	297	3054	95	198	3449	72	99	4246	44.0	15000		
5.81	258	3122	84	172	3526	64	86	4341	39.1	15000		
6.92	217	3246	74	145	3666	55	72	4514	34.2	15000		
8.70	172	2868	52	115	3077	37.0	57	3396	20.4	15000		
<b>ED 2090</b>												
14.28	105	4276	47.0	70	4829	35.4	35.0	5945	21.8	15000	23	
16.85	89	4493	41.9	59	5075	31.5	29.7	6248	19.4	15000		
17.68	85	4447	39.5	57	5022	29.8	28.3	6184	18.3	15000		
21.09	71	4807	35.8	47.4	5428	27.0	23.7	6683	16.6	15000		
24.48	61	5026	32.3	40.8	5676	24.3	20.4	6989	14.9	15000		
29.58	51	5320	28.3	33.8	6008	21.3	16.9	7397	13.1	15000		
30.30	49.5	5228	27.1	33.0	5904	20.4	16.5	7269	12.6	15000		
36.61	41.0	5533	23.7	27.3	6249	17.9	13.7	7693	11.0	15000		
41.52	36.1	4902	18.5	24.1	5107	12.9	12.0	5456	6.9	15000		
44.98	33.3	3629	12.7	22.2	3800	8.8	11.1	4092	4.8	15000		
50.17	29.9	4998	15.7	19.9	5202	10.9	10.0	5552	5.8	15000		
<b>ET 3090</b>												
58.98	25.4	6543	17.4	17.0	7390	13.1	8.5	9098	8.1	15000		15
61.86	24.2	6476	16.4	16.2	7314	12.4	8.1	8304	7.0	15000		
73.83	20.3	7000	14.9	13.5	7905	11.2	6.8	9732	6.9	15000		
75.40	19.9	7044	14.7	13.3	7955	11.1	6.6	9794	6.8	15000		
87.12	17.2	7356	13.3	11.5	8308	10.0	5.7	10228	6.1	15000		
101.1	14.8	7692	12.0	9.9	8687	9.0	4.9	10384	5.4	15000		
109.1	13.8	7869	11.3	9.2	8887	8.5	4.6	10941	5.3	15000		
126.6	11.9	8228	10.2	7.9	9293	7.7	4.0	11441	4.7	15000		
146.9	10.2	8604	9.2	6.8	9717	6.9	3.4	10774	3.8	15000		
152.9	9.8	8709	8.9	6.5	9835	6.7	3.3	12023	4.1	15000		
177.5	8.5	9107	8.1	5.6	10248	6.0	2.8	10973	3.2	15000		
209.2	7.2	7381	5.5	4.8	7820	3.9	2.4	8994	2.3	15000		
219.7	6.8	8429	6.0	4.6	9159	4.4	2.3	10512	2.5	15000		
252.7	5.9	7502	4.7	4.0	8129	3.4	2.0	9337	1.9	15000		
265.4	5.7	8765	5.2	3.8	9515	3.8	1.9	10906	2.2	15000		
305.4	4.9	7776	4.0	3.3	8446	2.9	1.6	9689	1.7	15000		
363.7	4.1	6105	2.6	2.7	6649	1.9	1.4	7657	1.1	15000		
<b>EQ 4090</b>												
409.3	3.7	11701	4.5	2.4	12828	3.3	1.2	13665	1.7	15000	11	
443.0	3.4	11982	4.2	2.3	12979	3.1	1.1	13813	1.6	15000		
512.4	2.9	12392	3.8	2.0	13025	2.7	0.98	14090	1.4	15000		
555.6	2.7	12244	3.5	1.8	12716	2.4	0.90	14246	1.3	15000		
654.3	2.3	12434	3.0	1.5	13023	2.1	0.76	14565	1.2	15000		
718.5	2.1	13004	2.8	1.4	13423	2.0	0.70	14750	1.1	15000		
779.1	1.9	11377	2.3	1.3	11906	1.6	0.64	13853	0.93	15000		
878.3	1.7	12778	2.3	1.1	13797	1.6	0.57	15155	0.90	15000		
1019	1.5	11665	1.8	0.98	12638	1.3	0.49	14664	0.75	15000		
1145	1.3	13474	1.8	0.87	14304	1.3	0.44	15703	0.72	15000		
1232	1.2	12047	1.5	0.81	13170	1.1	0.41	15254	0.65	15000		
1329	1.1	13813	1.6	0.75	14595	1.2	0.38	16018	0.63	15000		
1606	0.93	14174	1.4	0.62	14973	0.98	0.31	16427	0.54	15000		
1864	0.80	13195	1.1	0.54	14389	0.81	0.27	16606	0.47	15000		
1988	0.75	12975	1.0	0.50	13987	0.74	0.25	15714	0.41	15000		
2307	0.65	13340	0.91	0.43	14375	0.65	0.22	16026	0.36	15000		
2524	0.59	9025	0.56	0.40	9751	0.41	0.20	11100	0.23	15000		
2787	0.54	13815	0.78	0.36	14880	0.56	0.18	16430	0.31	15000		
3207	0.47	12288	0.60	0.31	13240	0.43	0.16	15009	0.25	15000		

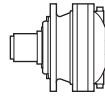

$i_{eff}$	1500			1000			500			$T_{2max}$ [Nm]	$P_T$ [kW]	
	$n_2$ [rpm]	$T_2$ [Nm]	$P_2$ [kW]	$n_2$ [rpm]	$T_2$ [Nm]	$P_2$ [kW]	$n_2$ [rpm]	$T_2$ [Nm]	$P_2$ [kW]			
<b>EM 1090</b>												
4.08	368	5188	200	245	5859	150	123	7213	93	15000	40	
5.05	297	5396	168	198	6094	126	99	7502	78	15000		
5.81	258	5516	149	172	6230	112	86	6866	62	15000		
6.92	217	4667	106	145	4967	75	72	5411	40.9	15000		
8.70	172	3564	64	115	3791	45.6	57	4142	24.9	15000		
<b>ED 2090</b>												
14.28	105	7554	83	70	8532	63	35.0	10504	38.5	15000	23	
16.85	89	7939	74	59	8966	56	29.7	11038	34.3	15000		
17.68	85	7814	69	57	8157	48.3	28.3	9233	27.4	15000		
21.09	71	8492	63	47.4	9591	47.6	23.7	11648	28.9	15000		
24.48	61	8880	57	40.8	9757	41.7	20.4	10681	22.8	15000		
29.58	51	7971	42.3	33.8	8475	30.0	16.9	9249	16.4	15000		
30.30	49.5	8266	42.9	33.0	8938	30.9	16.5	10306	17.8	15000		
36.61	41.0	8533	36.6	27.3	9301	26.6	13.7	10701	15.3	15000		
41.52	36.1	5815	22.0	24.1	6246	15.8	12.0	7230	9.1	15000		
44.98	33.3	4402	15.4	22.2	4643	10.8	11.1	5460	6.4	15000		
50.17	29.9	5956	18.6	19.9	6506	13.6	10.0	7515	7.8	15000		
<b>ET 3090</b>												
58.98	25.4	11561	30.8	17.0	12687	22.5	8.5	13568	12.0	15000		15
61.86	24.2	9533	24.2	16.2	10349	17.5	8.1	11850	10.0	15000		
73.83	20.3	12245	26.1	13.5	12977	18.4	6.8	13995	9.9	15000		
75.40	19.9	10714	22.3	13.3	11209	15.6	6.6	12532	8.7	15000		
87.12	17.2	12649	22.8	11.5	13036	15.7	5.7	14316	8.6	15000		
101.1	14.8	11074	17.2	9.9	11557	12.0	4.9	13379	6.9	15000		
109.1	13.8	12394	17.9	9.2	13221	12.7	4.6	14761	7.1	15000		
126.6	11.9	12590	15.6	7.9	13678	11.3	4.0	15062	6.2	15000		
146.9	10.2	11519	12.3	6.8	12458	8.9	3.4	14505	5.2	15000		
152.9	9.8	13016	13.4	6.5	14063	9.6	3.3	15452	5.3	15000		
177.5	8.5	11854	10.5	5.6	12999	7.7	2.8	15098	4.5	15000		
209.2	7.2	10493	7.9	4.8	11337	5.7	2.4	12901	3.2	15000		
219.7	6.8	12238	8.8	4.6	13209	6.3	2.3	15010	3.6	15000		
252.7	5.9	10881	6.8	4.0	11749	4.9	2.0	13357	2.8	15000		
265.4	5.7	12649	7.5	3.8	13683	5.4	1.9	15470	3.1	15000		
305.4	4.9	11280	5.8	3.3	12171	4.2	1.6	13826	2.4	15000		
363.7	4.1	8950	3.9	2.7	9673	2.8	1.4	11016	1.6	15000		
<b>EQ 4090</b>												
409.3	3.7	15216	5.8	2.4	16068	4.1	1.2	17617	2.3	15000	11	
443.0	3.4	15379	5.5	2.3	16239	3.8	1.1	17801	2.1	15000		
512.4	2.9	15683	4.8	2.0	16557	3.4	0.98	18145	1.9	15000		
555.6	2.7	15855	4.5	1.8	16736	3.2	0.90	18339	1.7	15000		
654.3	2.3	16205	3.9	1.5	17103	2.7	0.76	18736	1.5	15000		
718.5	2.1	16409	3.6	1.4	17316	2.5	0.70	18966	1.4	15000		
779.1	1.9	16339	3.3	1.3	17502	2.4	0.64	19168	1.3	15000		
878.3	1.7	16853	3.0	1.1	17781	2.1	0.57	19469	1.2	15000		
1019	1.5	17189	2.6	0.98	18133	1.9	0.49	19850	1.0	15000		
1145	1.3	17455	2.4	0.87	18411	1.7	0.44	20151	0.92	15000		
1232	1.2	17624	2.2	0.81	18588	1.6	0.41	20343	0.87	15000		
1329	1.1	17801	2.1	0.75	18774	1.5	0.38	20544	0.81	15000		
1606	0.93	18249	1.8	0.62	19243	1.3	0.31	21052	0.69	15000		
1864	0.80	18609	1.6	0.54	19620	1.1	0.27	21459	0.60	15000		
1988	0.75	17448	1.4	0.50	18393	0.97	0.25	20113	0.53	15000		
2307	0.65	17790	1.2	0.43	18751	0.85	0.22	20501	0.47	15000		
2524	0.59	12839	0.80	0.40	13806	0.57	0.20	15603	0.32	15000		
2787	0.54	18233	1.0	0.36	19215	0.72	0.18	21003	0.40	15000		
3207	0.47	17289	0.85	0.31	18557	0.61	0.16	20383	0.33	15000		

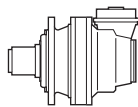

$i_{\text{eff}}$	1500			1000			500			$T_{2\text{max}}$ [Nm]	$P_T$ [kW]
	$n_2$ [rpm]	$T_2$ [Nm]	$P_2$ [kW]	$n_2$ [rpm]	$T_2$ [Nm]	$P_2$ [kW]	$n_2$ [rpm]	$T_2$ [Nm]	$P_2$ [kW]		
<b>EC 2090 - PDA 2090</b>											
12.24	123	2760	35.4	82	3117	26.7	40.8	3838	16.4	15000	18
15.15	99	3416	35.4	66	3858	26.7	33.0	4750	16.4	15000	
17.43	86	3931	35.4	57	4439	26.7	28.7	5465	16.4	15000	
20.76	72	4514	34.2	48.2	4753	24.0	24.1	5107	12.9	15000	
23.33	64	2283	15.4	42.9	2578	11.6	21.4	3174	7.1	15000	
26.84	56	2627	15.4	37.3	2966	11.6	18.6	3652	7.1	15000	
31.97	46.9	3129	15.4	31.3	3533	11.6	15.6	4350	7.1	15000	
40.19	37.3	3582	14.0	24.9	3753	9.8	12.4	4045	5.3	15000	
<b>EC 3090 - PDA 3090</b>											
42.84	35.0	5945	21.8	23.3	6714	16.4	11.7	8266	10.1	15000	15
50.55	29.7	6248	19.4	19.8	7056	14.6	9.9	8687	9.0	15000	
53.03	28.3	6184	18.3	18.9	6983	13.8	9.4	8194	8.1	15000	
65.97	22.7	6457	15.4	15.2	7292	11.6	7.6	8977	7.1	15000	
73.44	20.4	6989	14.9	13.6	7893	11.3	6.8	9717	6.9	15000	
77.85	19.3	7112	14.4	12.8	8032	10.8	6.4	9888	6.7	15000	
90.90	16.5	7269	12.6	11.0	8085	9.3	5.5	8813	5.1	15000	
97.45	15.4	7608	12.3	10.3	8592	9.2	5.1	10578	5.7	15000	
113.1	13.3	7955	11.1	8.8	8984	8.3	4.4	10501	4.9	15000	
120.6	12.4	7913	10.3	8.3	8286	7.2	4.1	9334	4.1	15000	
140.0	10.7	8104	9.1	7.1	8393	6.3	3.6	9617	3.6	15000	
161.1	9.3	7216	7.0	6.2	7474	4.9	3.1	8537	2.8	15000	
169.1	8.9	8238	7.7	5.9	8684	5.4	3.0	9985	3.1	15000	
194.6	7.7	7336	5.9	5.1	7704	4.1	2.6	8867	2.4	15000	
231.8	6.5	5772	3.9	4.3	6047	2.7	2.2	6990	1.6	15000	
<b>EC 4090 - PDA 4090</b>											
285.8	5.2	8898	4.9	3.5	9657	3.5	1.7	11063	2.0	15000	10
321.5	4.7	10884	5.3	3.1	12248	4.0	1.6	13220	2.2	15000	
341.1	4.4	11078	5.1	2.9	12149	3.7	1.5	13144	2.0	15000	
395.8	3.8	11585	4.6	2.5	12747	3.4	1.3	13603	1.8	15000	
467.1	3.2	12173	4.1	2.1	12996	2.9	1.1	13913	1.6	15000	
503.8	3.0	12131	3.8	2.0	12602	2.6	0.99	14058	1.5	15000	
564.4	2.7	12624	3.5	1.8	13056	2.4	0.89	14276	1.3	15000	
623.6	2.4	10399	2.6	1.6	11250	1.9	0.80	12829	1.1	15000	
706.5	2.1	12523	2.8	1.4	13246	2.0	0.71	14717	1.1	15000	
820.0	1.8	11431	2.2	1.2	12043	1.5	0.61	14005	0.89	15000	
874.5	1.7	11105	2.0	1.1	12000	1.4	0.57	13661	0.82	15000	
1015	1.5	11427	1.8	0.99	12342	1.3	0.49	14042	0.72	15000	
1168	1.3	10154	1.4	0.86	10972	0.98	0.43	12491	0.56	15000	
1226	1.2	11847	1.5	0.82	12789	1.1	0.41	14537	0.62	15000	
1411	1.1	10530	1.2	0.71	11371	0.84	0.35	12934	0.48	15000	
1680	0.89	8340	0.78	0.60	9023	0.56	0.30	10291	0.32	15000	
1748	0.86	6325	0.57	0.57	6890	0.41	0.29	7939	0.24	15000	
2113	0.71	6585	0.49	0.47	7165	0.36	0.24	8245	0.20	15000	

Tutti i rapporti evidenziati (es. 12.24) hanno dimensioni particolari della coppia conica in certe versioni; vedere tavole dimensionali.

All ratios grey highlighted (ex. 12.24) have specific dimensions of the bevel gear set in some versions; see dimensional tables.

Alle mit (es. 12.24) gekennzeichneten Übersetzungen haben in bestimmten Versionen besondere Dimensionen des Kegelradtriebs. Siehe auch Dimensionstabellen.

Les rapports repérés par (es. 12.24) ont des dimensions de couple conique particulières. Voir les tableaux dimensionnels.

Todas las relaciones indicadas con (es. 12.24) tienen dimensiones particulares del par cónico según las versiones; ver las tablas de dimensión.

As relações marcadas com (es. 12.24) têm dimensões particulares da engrenagem cônica em certas versões; vide tabelas dimensionais.



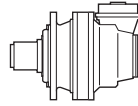

$i_{eff}$	1500			1000			500			$T_{2max}$ [Nm]	$P_T$ [kW]
	$n_2$ [rpm]	$T_2$ [Nm]	$P_2$ [kW]	$n_2$ [rpm]	$T_2$ [Nm]	$P_2$ [kW]	$n_2$ [rpm]	$T_2$ [Nm]	$P_2$ [kW]		
<b>EC 2090 - PDA 2090</b>											
12.24	123	4877	63	82	5507	47.1	40.8	6781	29.0	5000	18
15.15	99	6036	63	66	6817	47.1	33.0	8393	29.0	5000	
17.43	86	6866	62	57	7169	43.1	28.7	7941	23.9	5000	
20.76	72	5411	40.9	48.2	5650	28.5	24.1	6246	15.8	5000	
23.33	64	4034	27.2	42.9	4556	20.5	21.4	5609	12.6	5000	
26.84	56	4641	27.2	37.3	5241	20.5	18.6	6453	12.6	5000	
31.97	46.9	5528	27.2	31.3	5896	19.3	15.6	6849	11.2	5000	
40.19	37.3	4349	17.0	24.9	4539	11.8	12.4	5322	6.9	5000	
<b>EC 3090 - PDA 3090</b>											
42.84	35.0	10504	38.5	23.3	11863	29.0	11.7	13030	15.9	5000	15
50.55	29.7	11039	34.3	19.8	12309	25.5	9.9	13280	13.8	5000	
53.03	28.3	9233	27.4	18.9	10034	19.8	9.4	11504	11.4	5000	
65.97	22.7	11408	27.2	15.2	12883	20.5	7.6	13780	10.9	5000	
73.44	20.4	10681	22.8	13.6	11177	15.9	6.8	12458	8.9	5000	
77.85	19.3	12373	25.0	12.8	12996	17.5	6.4	14097	9.5	5000	
90.90	16.5	10306	17.8	11.0	11165	12.9	5.5	12749	7.3	5000	
97.45	15.4	12244	19.7	10.3	12880	13.8	5.1	14537	7.8	5000	
113.1	13.3	11209	15.6	8.8	11730	10.9	4.4	13711	6.3	5000	
120.6	12.4	10900	14.2	8.3	11792	10.2	4.1	13442	5.8	5000	
140.0	10.7	11222	12.6	7.1	12133	9.1	3.6	13818	5.2	5000	
161.1	9.3	9975	9.7	6.2	10788	7.0	3.1	12293	4.0	5000	
169.1	8.9	11641	10.8	5.9	12527	7.8	3.0	14309	4.4	5000	
194.6	7.7	10348	8.4	5.1	11184	6.0	2.6	12731	3.4	5000	
231.8	6.5	8194	5.6	4.3	8872	4.0	2.2	10128	2.3	5000	
<b>EC 4090 - PDA 4090</b>											
285.8	5.2	12862	7.1	3.5	13871	5.1	1.7	15623	2.9	5000	10
321.5	4.7	14727	7.2	3.1	15556	5.1	1.6	17064	2.8	5000	
341.1	4.4	14845	6.8	2.9	15680	4.8	1.5	17198	2.6	5000	
395.8	3.8	15148	6.0	2.5	15996	4.2	1.3	17539	2.3	5000	
467.1	3.2	15489	5.2	2.1	16354	3.7	1.1	17926	2.0	5000	
503.8	3.0	15648	4.9	2.0	16520	3.4	0.99	18105	1.9	5000	
564.4	2.7	15888	4.4	1.8	16771	3.1	0.89	18377	1.7	5000	
623.6	2.4	14860	3.7	1.6	15804	2.7	0.80	17311	1.5	5000	
706.5	2.1	16372	3.6	1.4	17278	2.6	0.71	18925	1.4	5000	
820.0	1.8	16511	3.2	1.2	17621	2.3	0.61	19296	1.2	5000	
874.5	1.7	15664	2.8	1.1	16524	2.0	0.57	18090	1.1	5000	
1015	1.5	15975	2.5	0.99	16850	1.7	0.49	18443	0.95	5000	
1168	1.3	14446	1.9	0.86	15535	1.4	0.43	17558	0.79	5000	
1226	1.2	16379	2.1	0.82	17273	1.5	0.41	18901	0.81	5000	
1411	1.1	14946	1.7	0.71	16067	1.2	0.35	18149	0.67	5000	
1680	0.89	11926	1.1	0.60	12836	0.80	0.30	14526	0.45	5000	
1748	0.86	9290	0.84	0.57	10042	0.60	0.29	11440	0.34	5000	
2113	0.71	9636	0.72	0.47	10410	0.52	0.24	11847	0.29	5000	

Tutti i rapporti evidenziati (es. 12.24) hanno dimensioni particolari della coppia conica in certe versioni; vedere tavole dimensionali.

All ratios grey highlighted (ex. 12.24) have specific dimensions of the bevel gear set in some versions; see dimensional tables.

Alle mit (es. 12.24) gekennzeichneten Übersetzungen haben in bestimmten Versionen besondere Dimensionen des Kegelradtriebs. Siehe auch Dimensionstabellen.

Les rapports repérés par (es. 12.24) ont des dimensions de couple conique particulières. Voir les tableaux dimensionnels.

Todas las relaciones indicadas con (es. 12.24) tienen dimensiones particulares del par cónico según las versiones; ver las tablas de dimensión.

As relações marcadas com (es. 12.24) têm dimensões particulares da engrenagem cônica em certas versões; vide tabelas dimensionais.



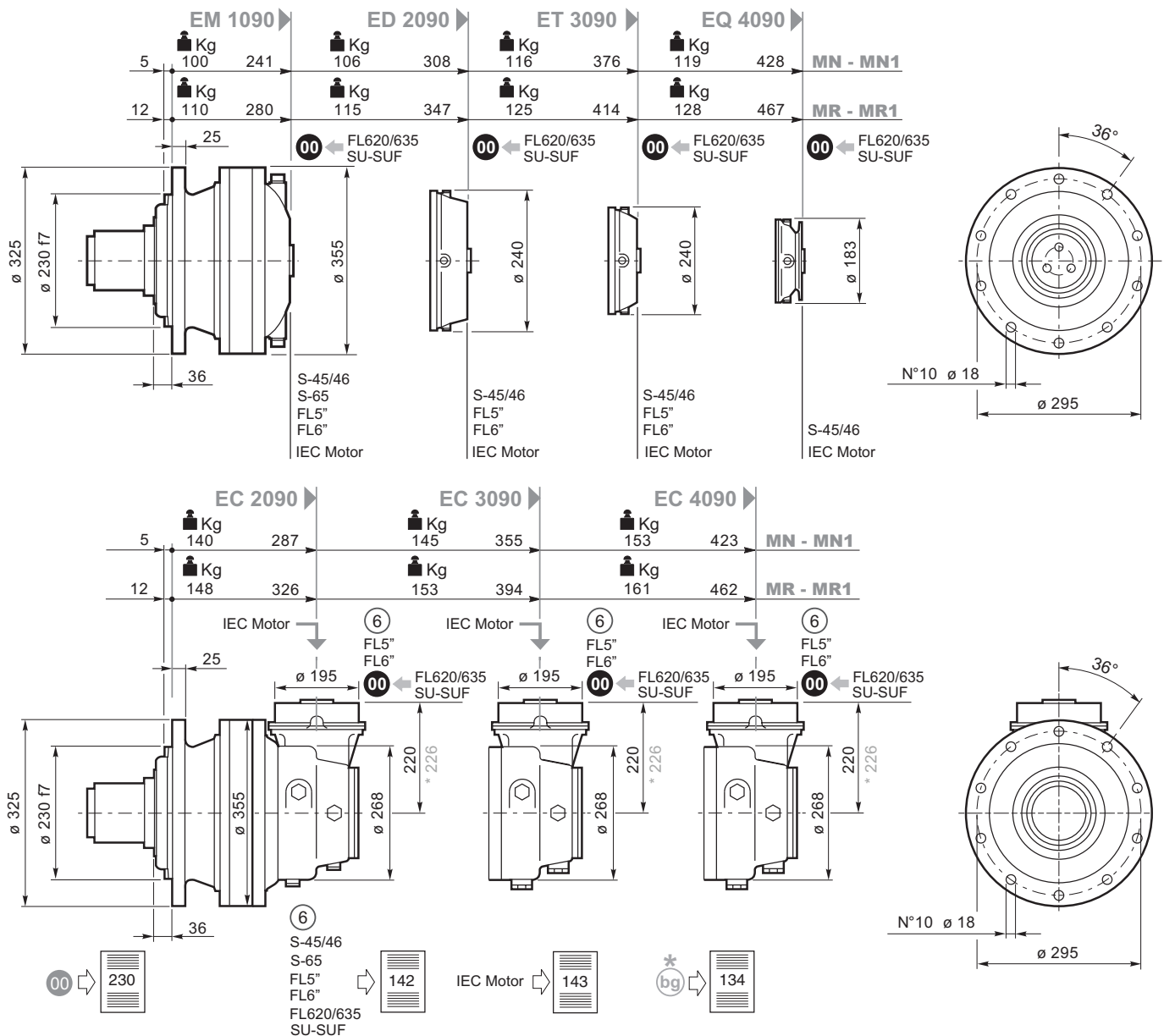
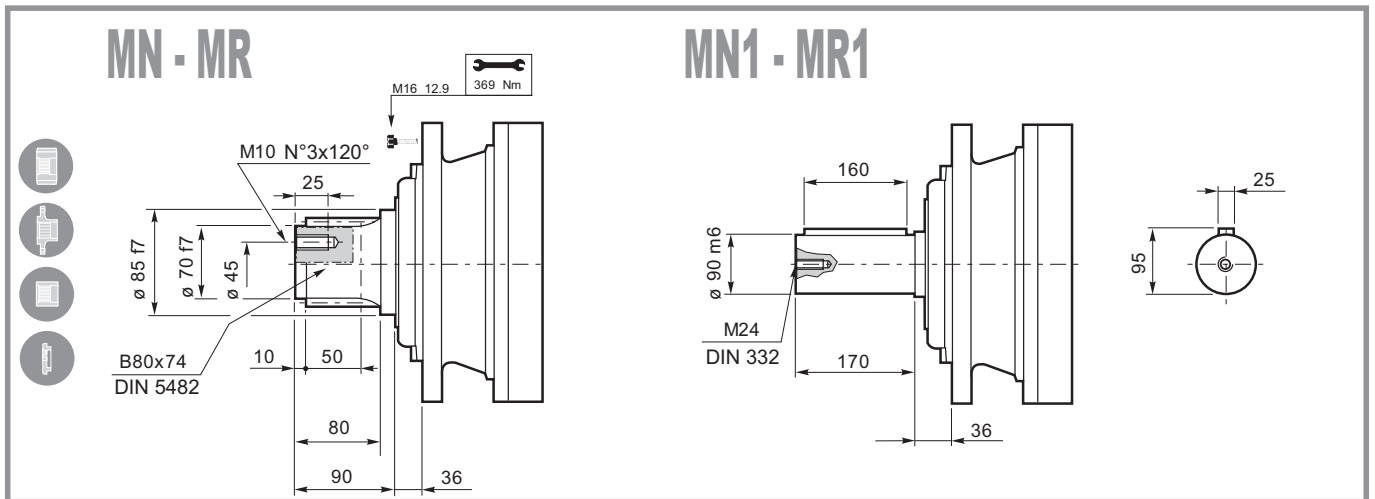

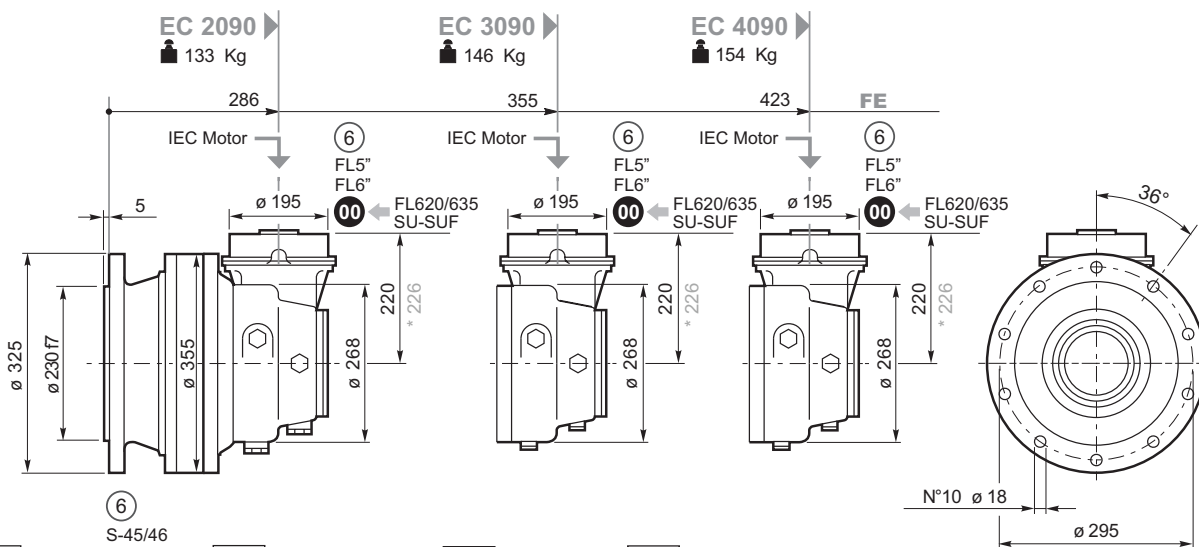
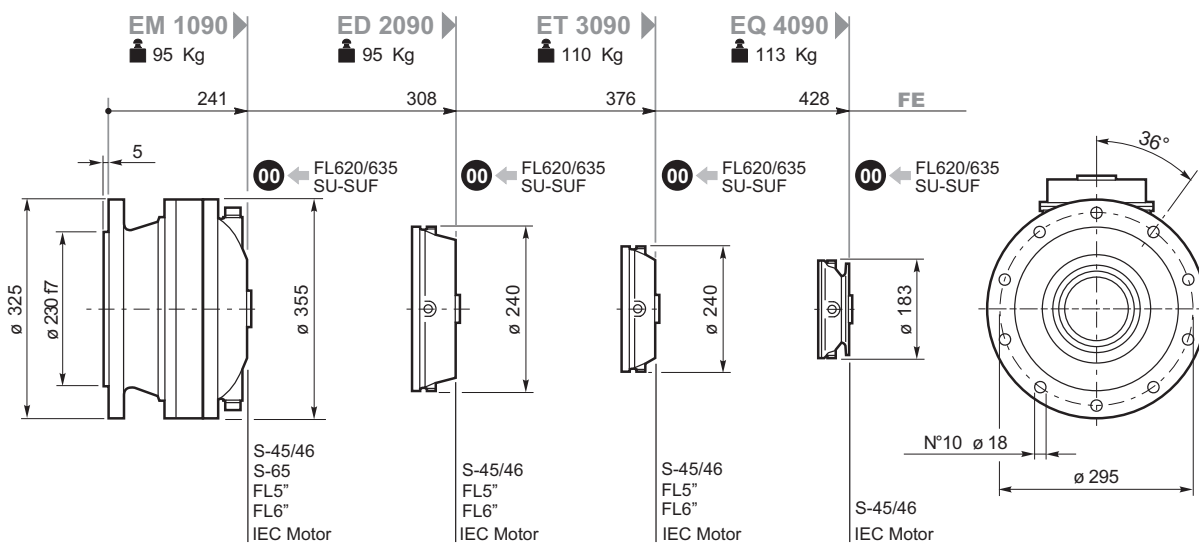
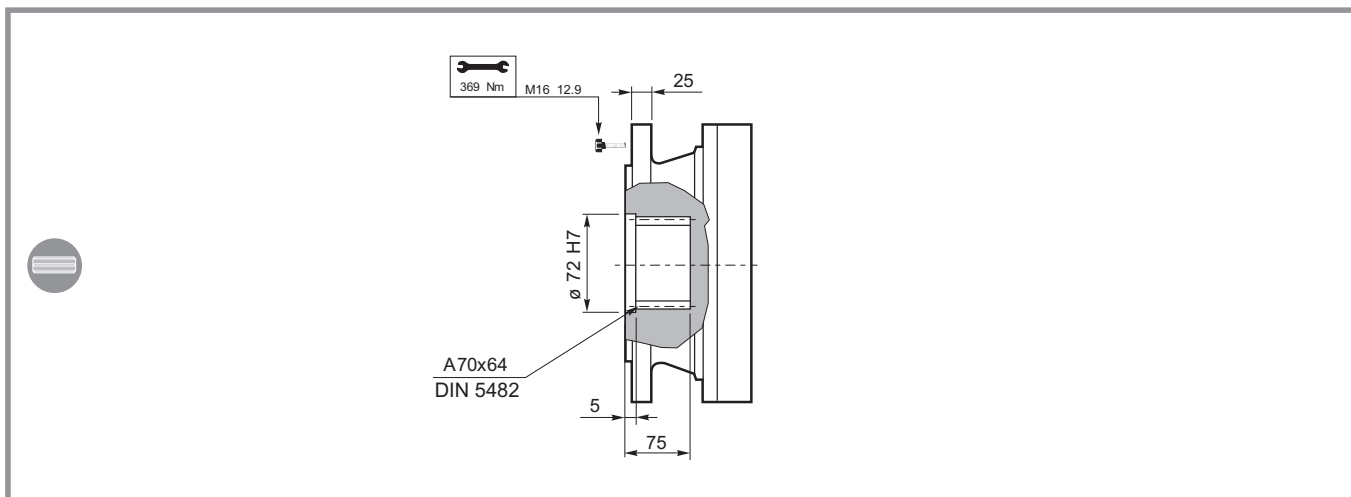



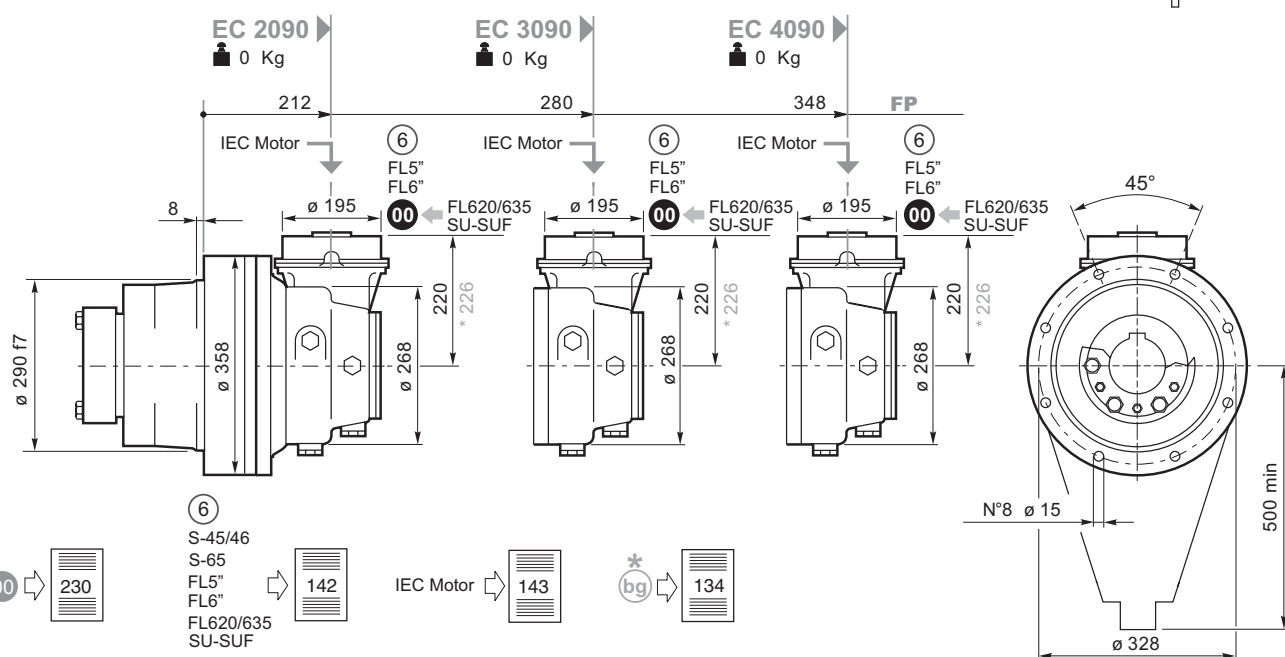
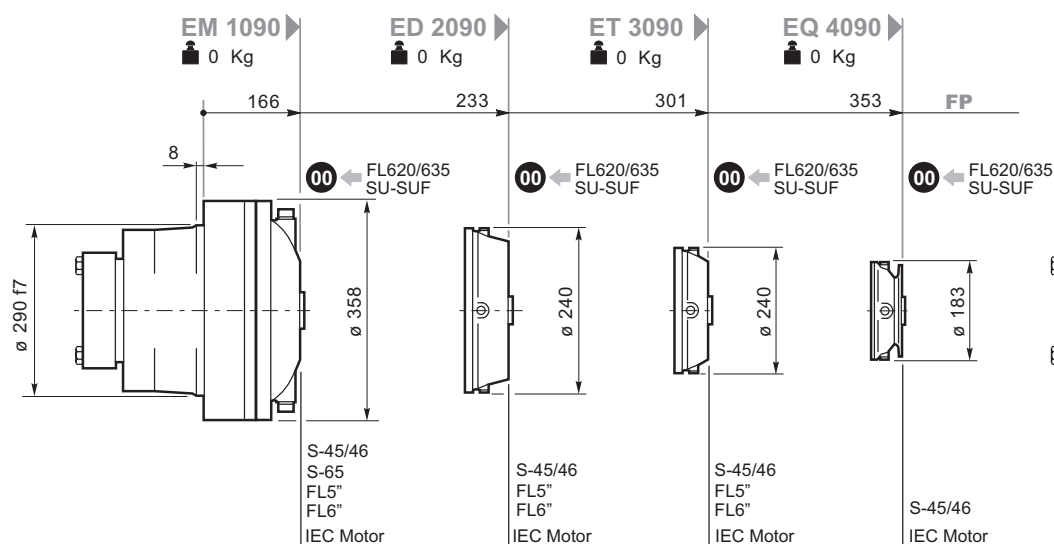
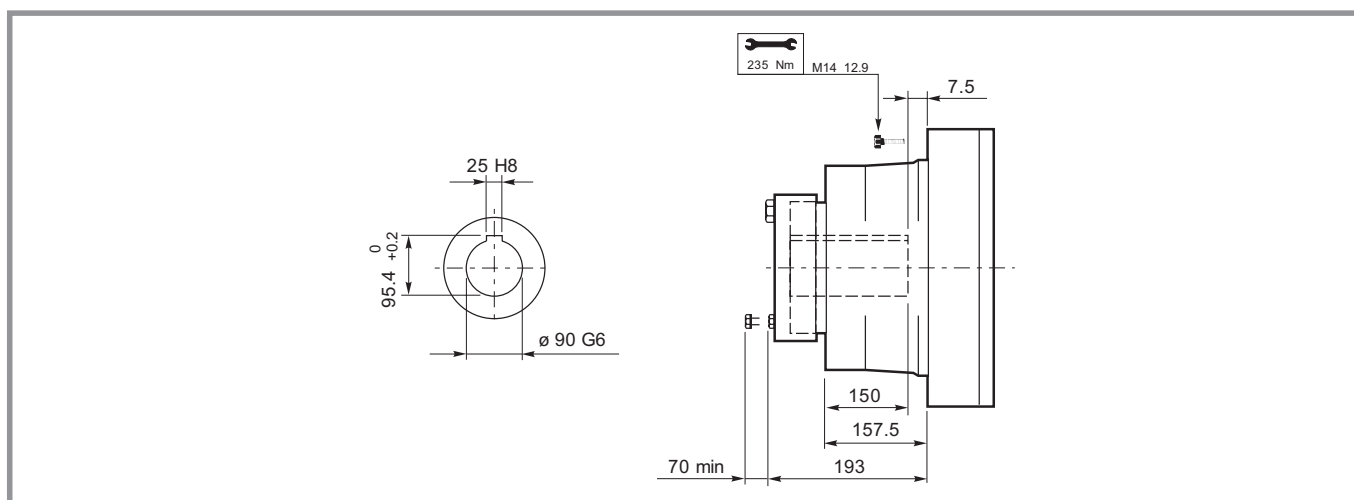

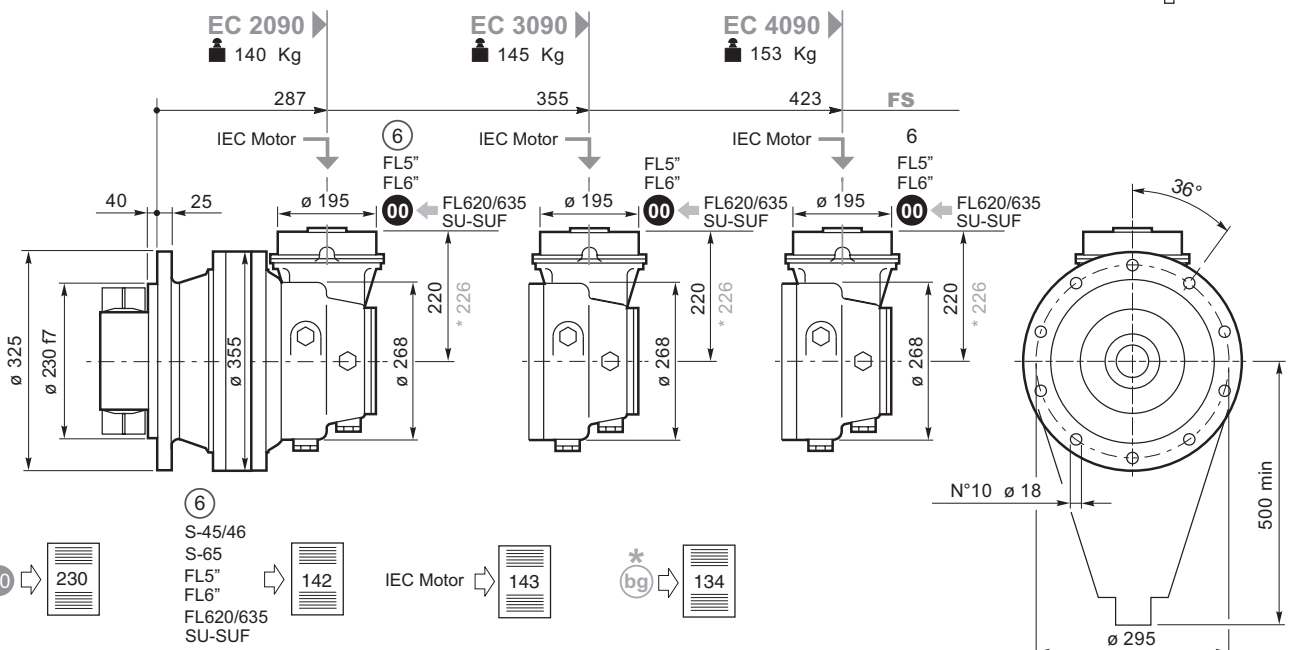
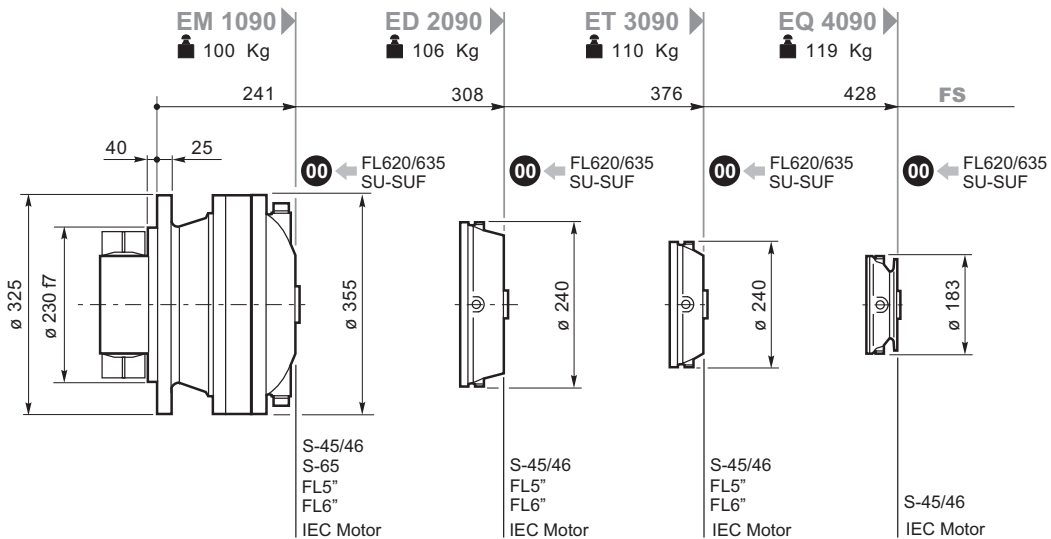
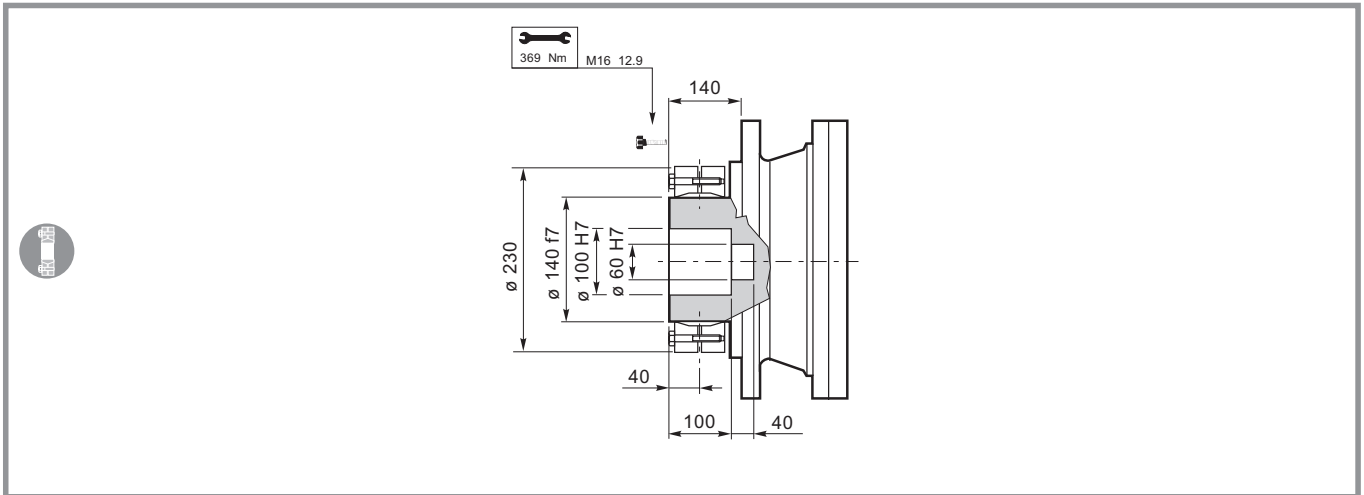

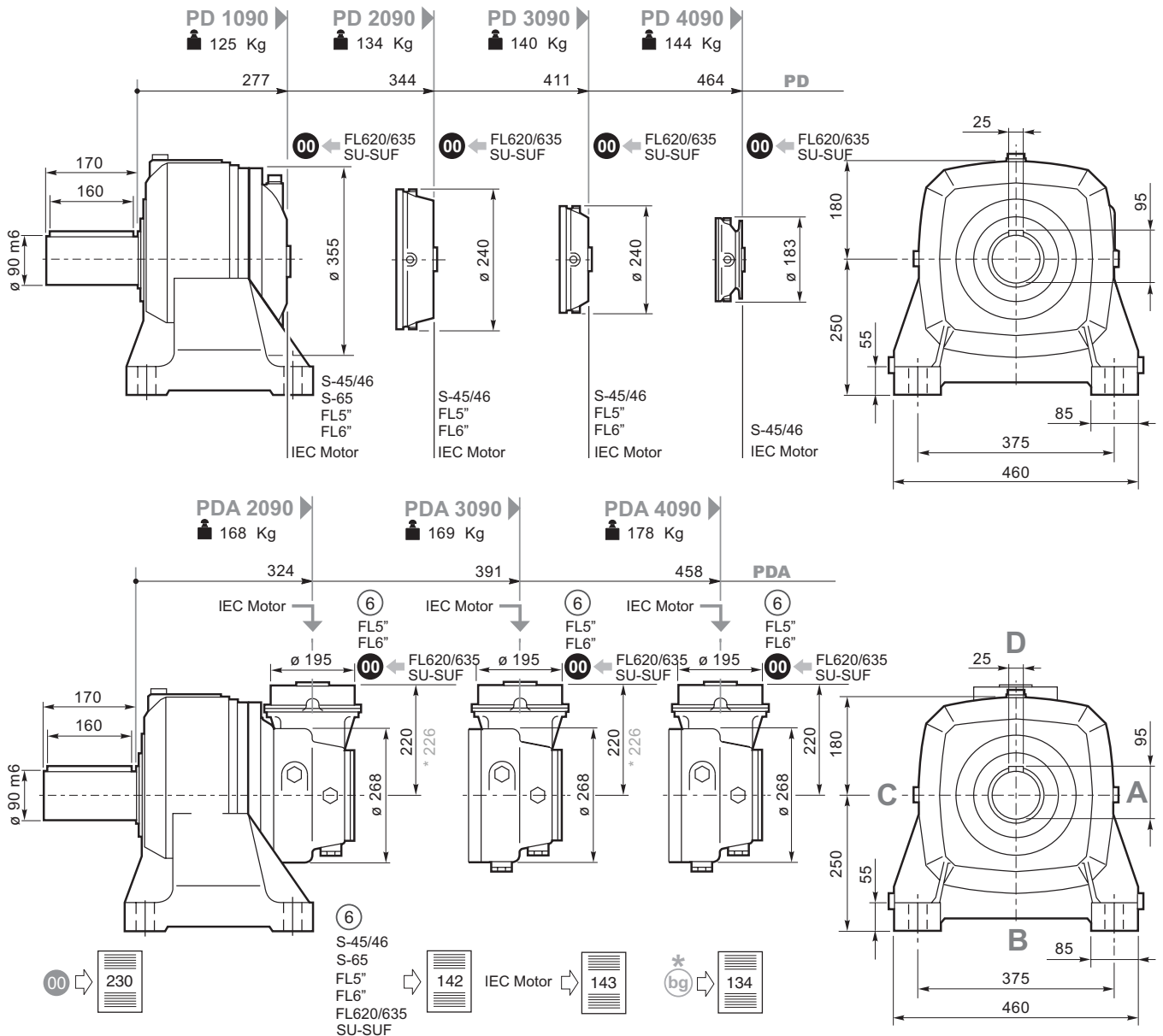
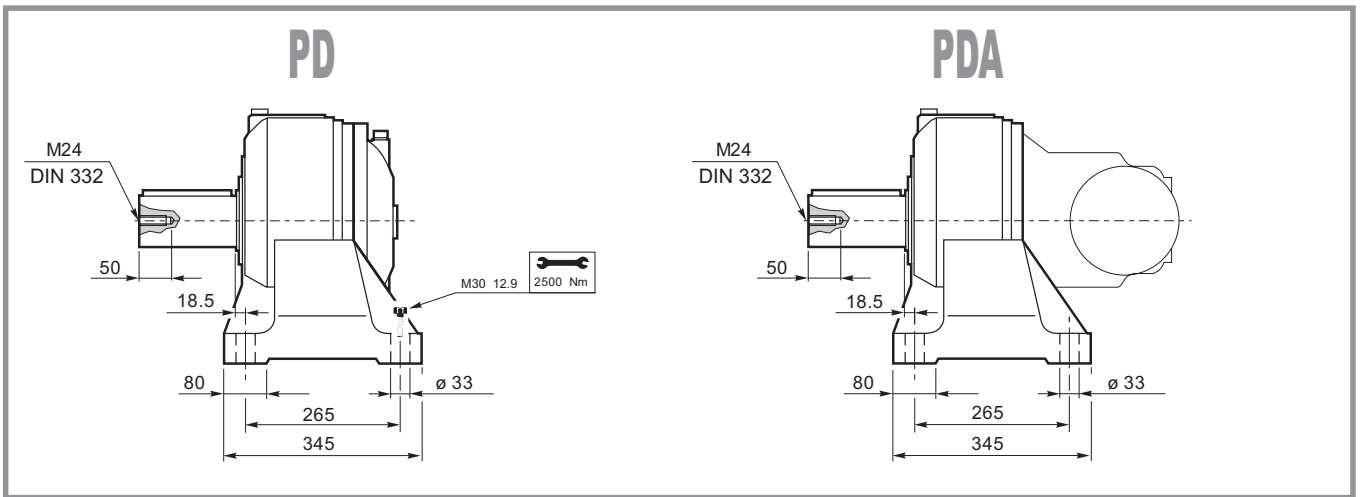



## S45CR1-S46C1

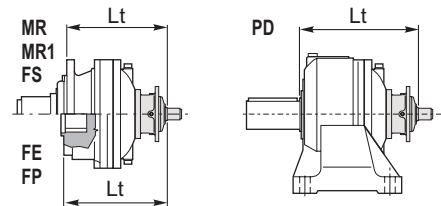
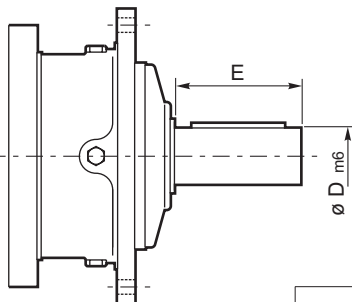

	D m6	E		Lt				
				MN-MN1-FS	MR-MR1	FE	FP	PD
S45 CR1	65	105	EM 1090	371	410	371	296	407
			ED 2090	371	410	371	296	407
			ET 3090	439	477	439	364	564
S46 C1	65	105	EM 1090	412	451	412	337	514
			ET 2090	412	451	412	337	447
			ET 3090	480	518	518	405	581

## SU2

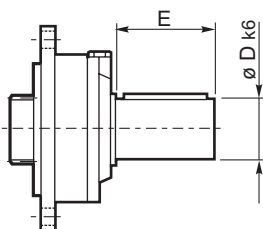

	D k6	E		Lt			
				MN-MN1 FE-FS	MR MR1	FP	PD
SU 2	40	58	EM 1090	301	340	226	337
			ED 2090	368	407	293	404
			ET 3090	436	474	361	471
			EQ 4090	488	527	413	524

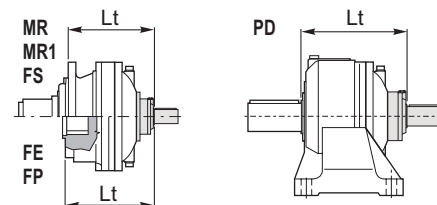

## ⑥ 48.82

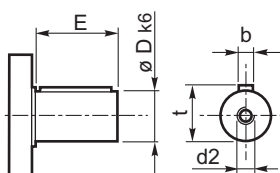

	D	E		Lt
				MN-MN1-MR-MR1-FS-FP-PDA
48.82	48	82	EC 2090	280
			EC 3090	280
			EC 4090	280

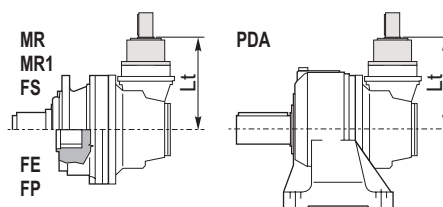

## FL250-FL350-FL450 FL750 FL760-FL960

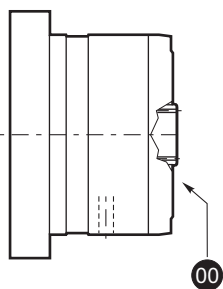

FL620/10  
FL635/10

FL620U-FL635U

SAE A-AA  
Shaft FE

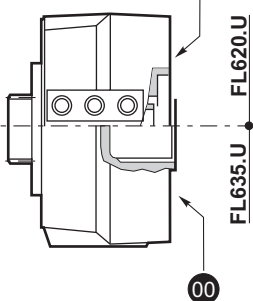

		Lt			
		MN-MN1 FE-FS	MR-MR1	FP	PD-PDA
FL250 FL350 FL450	EM 1090	341	380	266	377
	ED 2090	402	440	327	438
	ET 3090	469	508	394	505
	EC 2090	280	280	280	280
	EC 2090*	377	377	377	377
	EC 3090	280	280	280	280
	EC 3090*	377	377	377	377
FL750	EM 1090	354	393	279	390
	ED 2090	415	453	340	451
	ET 3090	482	521	407	518
FL760- FL960	EM 1090	368	407	293	405
	ED 2090	442	480	366.9	—

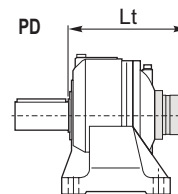
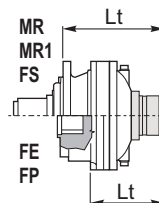

		Lt				
		MN-MN1 FE-FS	MR-MR1	FP	PD	
FL620/U	EM 1090	345.5	348.5	270.5	381.5	
	ED 2090	412.5	451.5	337.5	448.5	
	ET 3090	480.5	518.5	405.5	515.5	
	EQ 4090	532.5	571.5	457.5	568.5	
	EC 2090	324.5	324.5	324.5	324.5	
	EC 2090*	330.5	330.5	330.5	330.5	
	EC 3090	324.5	324.5	324.5	324.5	
	EC 3090*	330.5	330.5	330.5	330.5	
	EC 4090	324.5	324.5	324.5	324.5	
	EC 4090*	330.5	330.5	330.5	330.5	
	FL635U	EM 1090	332	371	257	368
		ED 2090	399	438	342	435
ET 3090		467	505	392	502	
EQ 4090		519	558	444	555	
EC 2090		311	311	311	311	
EC 2090*		317	317	317	317	
EC 3090		311	311	311	311	
EC 3090*		317	317	317	317	
EC 4090		311	311	311	311	
EC 4090*		317	317	317	317	
FL620/10	EQ 4090	492	531	417	475	
FL635/10	EQ 4090	474	512	398	456	

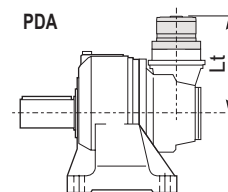
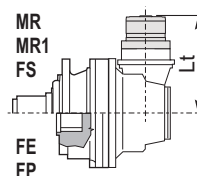

## IEC Motor

		Lt							
		IEC 63	IEC 71	IEC 80 90	IEC 100 112	IEC 132	IEC 160 180	IEC 200	IEC 225
EM 1090	MN-MN1-FE-FS	261	263	268	269	336	367	380	408
EM 1090	MR-MR1	300	302	307	308	375	406	419	447
EM 1090	FP								
ED 2090	MN-MN1-FE-FS	328	330	335	336	403	434	444	475
ED 2090	MR-MR1	367	369	374	375	442	473	483	514
ED 2090	FP								
ET 3090	MN-MN1-FE-FS	396	389	403	404	471	502	512	543
ET 3090	MR-MR1	434	436	441	442	509	540	550	581
ET 3090	FP								
EQ 4090	MN-MN1-FE-FS	448	450	455	456	523			
EQ 4090	MR-MR1	487	489	494	495	562			
EQ 4090	FP								
PD 1090	PD	297	299	304	305	372	403	416	444
PD 2090	PD	364	366	371	372	506	537	483	511
PD 3090	PD	431	433	438	439	506	537	550	578
PD 4090	PD	484	486	491	492	559	439	550	578
EC 2090	MN-MR-MN1-MR1 FE-FS-FP-PDA	240	242	247	248	315	346		
EC 2090*		246	248	253	254	321	352		
EC 3090		240	242	247	248	315	346		
EC 3090*		246	248	253	254	321	352		
EC 4090		240	242	247	248	315	346		
EC 4090*		246	248	253	254	321	352		

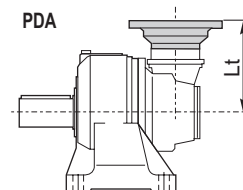
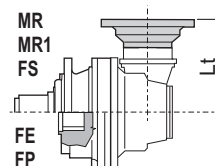
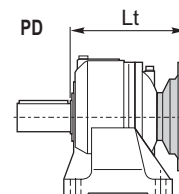
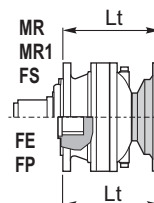

\* (bg)





**Flangia ruota**  
Driving flange  
Radnabenflansch  
Flasque de roue  
Brida de la rueda  
Flange de roda

**FA 090**

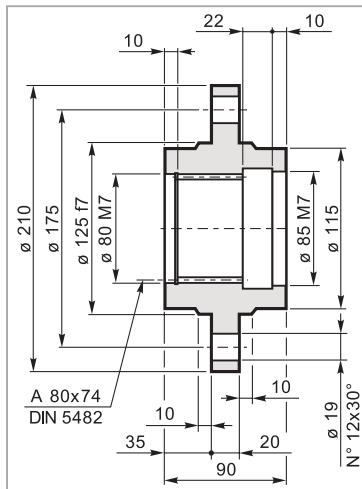

Mat. C40 UNI EN 10083  
Code: 34701521800



**Flangia ruota**  
Driving flange  
Radnabenflansch  
Flasque de roue  
Brida de la rueda  
Flange de roda

**FR 090**

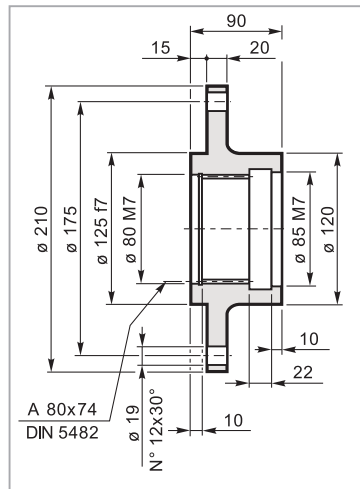

Mat. C40 UNI EN 10083  
Code: 34701421800



**Pignoni**  
Pinion  
Ritzel  
Pignon  
Piñones  
Pinhões

**IR 090**

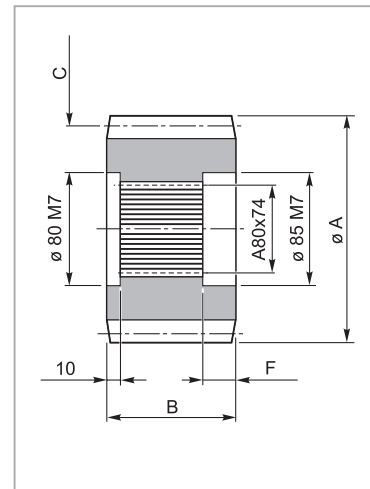

code	A	B	C	F
335.3543.0600	159	90	M=10 Z=13 X=0.5	31



**Manicotto scanalato**  
Splined bush  
Keilmuffe  
Manchon cannelée  
Manguito acanalado  
Luva ranhurada

**MS 090**

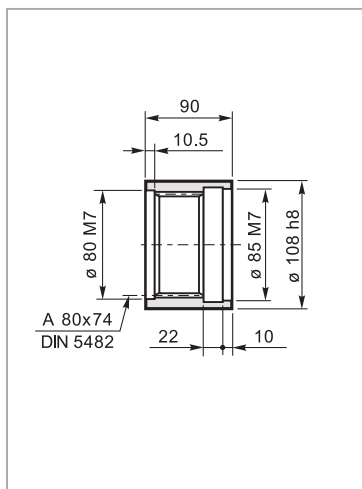

Mat. 39NiCrMo3 UNI EN 10083  
Code: 39103040600



**Rondella di fermo**  
Shaft cover  
Gegenscheibe  
Rondelle frein  
Arandela de bloqueo  
Amuela de encosto

**RDF 090**

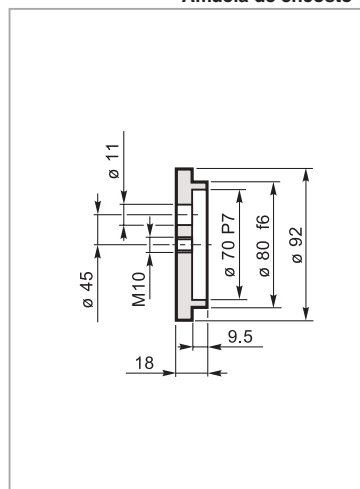

Mat. C40 UNI EN 10083  
Code: 37200940800



**Barra scanalata**  
Splined bar  
Zugspindel  
Barre cannelée  
Barra acanalada  
Barra ranhurada

**BS 090**

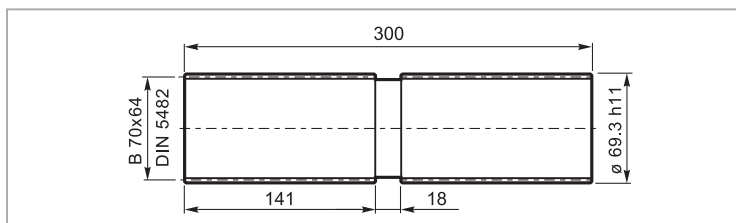

Mat. 39NiCrMo3 UNI EN 10083  
Code: 39127130100

Carichi radiali sugli alberi uscita / Radial loads on output shafts  
 Radiallasten auf de Abtriebswellen / Charges radiales sur les arbres de sortie  
 Cargas sobre los ejes de salida / Cargas radiais nos eixos de saida

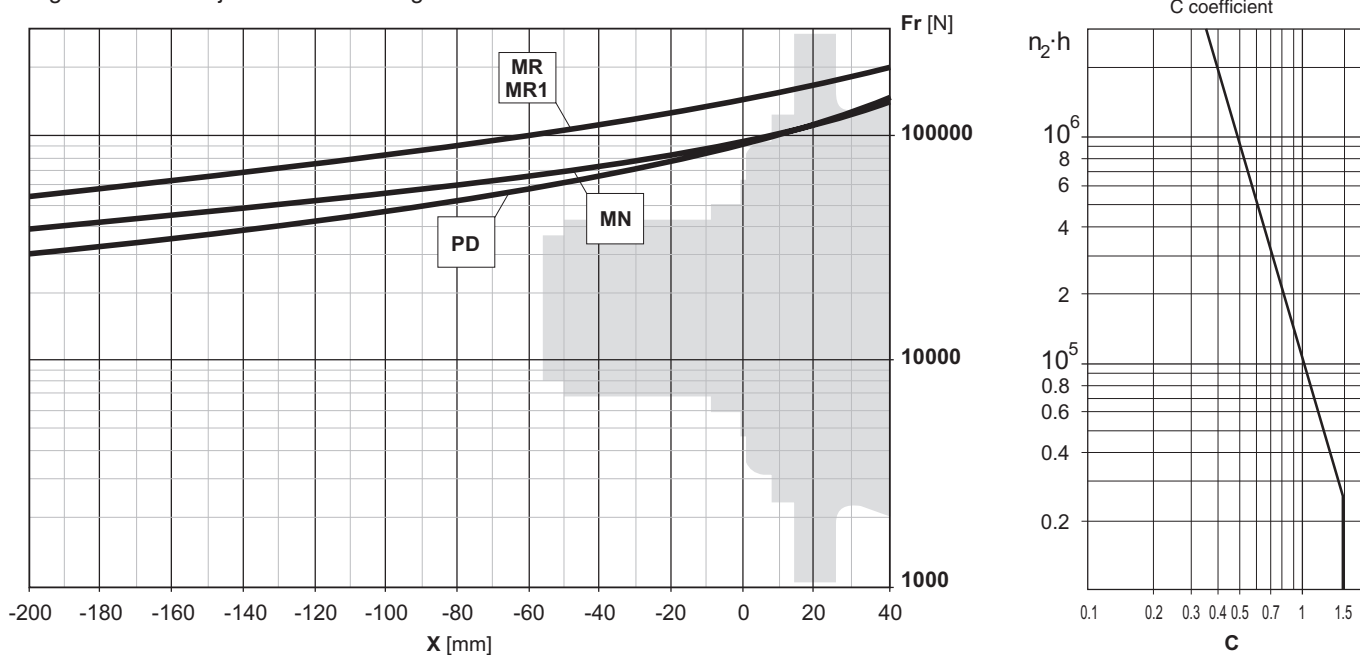

Carichi assiali / Axial loads / Axialkräfte / Charges axiales / Cargas axiales / Forças axiais

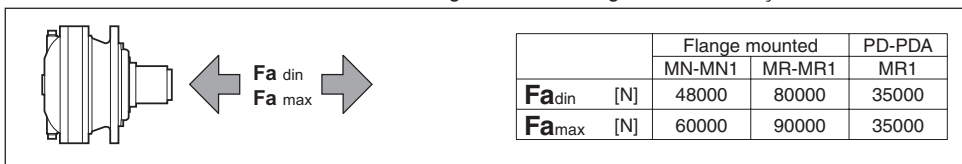

Carichi radiali sugli alberi entrata / Radial loads on input shafts  
 Radiallasten auf de Antriebswellen / Charges radiales sur les arbres d'entrée  
 Cargas sobre los ejes de entrada / Cargas radiais nos eixos de entrada

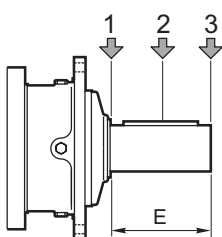

Type	E	$Fr$ [N]					
		$n_1 \cdot h = 10^7$			$n_1 \cdot h = 10^8$		
		1	2	3	1	2	3
S45 CR1	105	10000	6000	4000	5000	3000	2000
S46 C1	105	14000	8800	6400	7000	4400	3200
S65 CR1	130	23800	15500	9600	11900	7800	4800

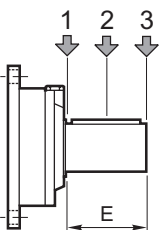

Type	E	$Fr$ [N]					
		$n_1 \cdot h = 10^7$			$n_1 \cdot h = 10^8$		
		1	2	3	1	2	3
SU2	58	3000	2000	1500	1400	1000	700



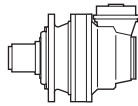

$i_{eff}$	1500			1000			500			$T_{2max}$ [Nm]	$P_T$ [kW]
	$n_2$ [rpm]	$T_2$ [Nm]	$P_2$ [kW]	$n_2$ [rpm]	$T_2$ [Nm]	$P_2$ [kW]	$n_2$ [rpm]	$T_2$ [Nm]	$P_2$ [kW]		

### EC 2091 - PDA 2091

<b>11.22</b>	134	3977	56	89	4492	41.9	44.6	5530	25.8	15000	
<b>13.89</b>	108	4137	46.8	72	4672	35.2	36.0	5752	21.7	15000	
<b>15.98</b>	94	4229	41.6	63	4776	31.3	31.3	5880	19.3	15000	
<b>17.68</b>	85	3970	35.3	57	4484	26.6	28.3	5520	16.4	15000	
<b>20.34</b>	74	4547	35.1	49.2	5135	26.4	24.6	6322	16.3	15000	18
<b>24.59</b>	61	3971	25.4	40.7	4485	19.1	20.3	5522	11.8	15000	
<b>28.29</b>	53	4569	25.4	35.3	5160	19.1	17.7	6353	11.8	15000	
<b>33.70</b>	44.5	4794	22.4	29.7	5002	15.5	14.8	5351	8.3	15000	
<b>42.37</b>	35.4	3604	13.4	23.6	3775	9.3	11.8	4067	5.0	15000	

**1500**  
HOURS LIFE

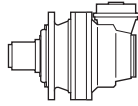

**091**

$i_{eff}$	1500			1000			500			$T_{2max}$ [Nm]	$P_T$ [kW]
	$n_2$ [rpm]	$T_2$ [Nm]	$P_2$ [kW]	$n_2$ [rpm]	$T_2$ [Nm]	$P_2$ [kW]	$n_2$ [rpm]	$T_2$ [Nm]	$P_2$ [kW]		

**EC 2091 - PDA 2091**

<b>11.22</b>	134	7027	98	89	7936	74	44.6	9771	45.6	5000	18
<b>13.89</b>	108	7309	83	72	7955	60	36.0	8774	33.1	5000	
<b>15.98</b>	94	6799	67	63	7105	46.6	31.3	7796	25.6	5000	
<b>17.68</b>	85	7014	62	57	7922	46.9	28.3	9233	27.4	5000	
<b>20.34</b>	74	6983	54	49.2	7280	37.5	24.6	8203	21.1	5000	
<b>24.59</b>	61	7016	44.8	40.7	7924	33.7	20.3	9218	19.6	5000	
<b>28.29</b>	53	7226	40.1	35.3	7594	28.1	17.7	8781	16.3	5000	
<b>33.70</b>	44.5	5696	26.6	29.7	5966	18.5	14.8	6925	10.8	5000	
<b>42.37</b>	35.4	4374	16.2	23.6	4576	11.3	11.8	5386	6.7	5000	

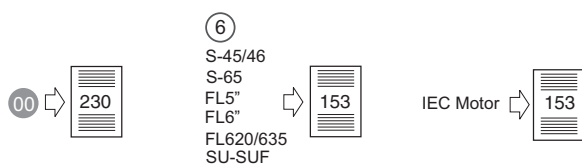
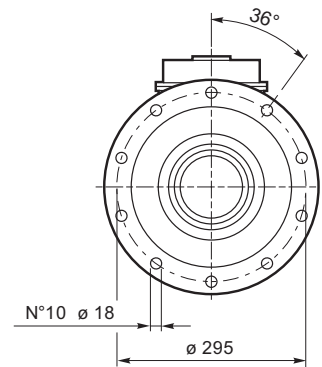
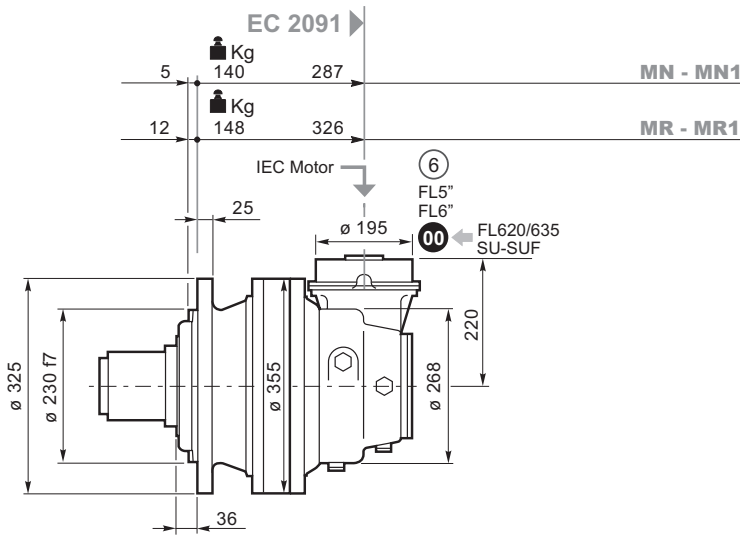
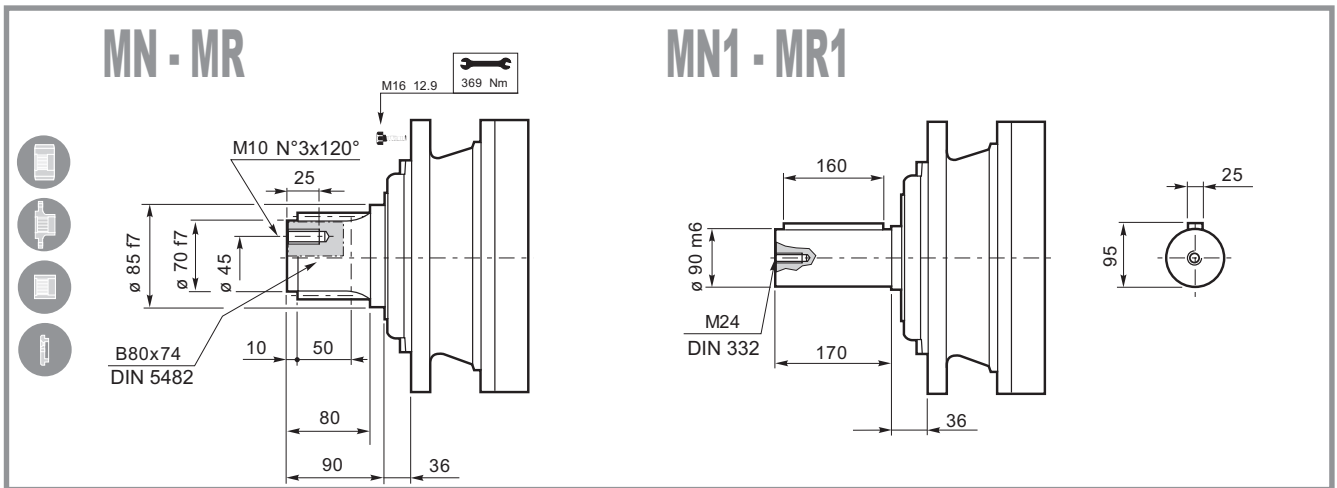

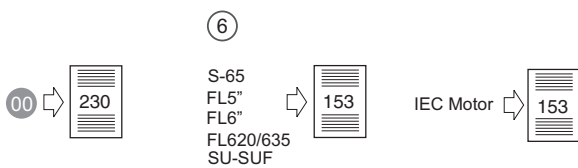
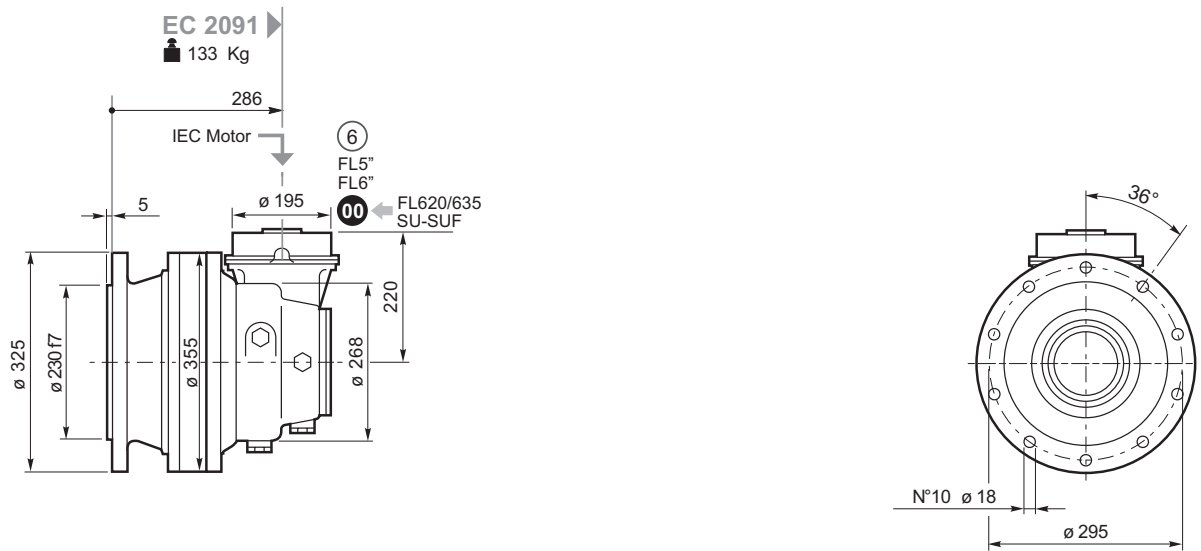
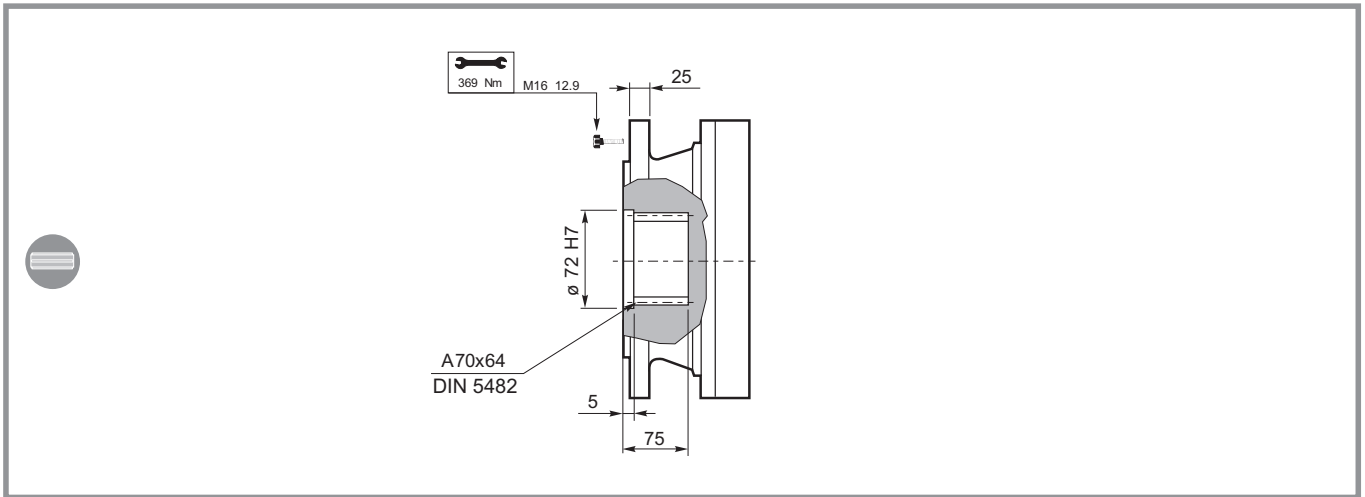

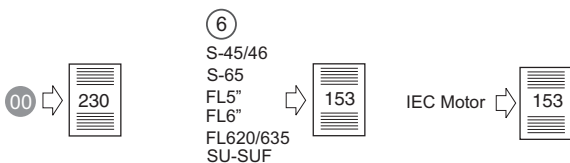
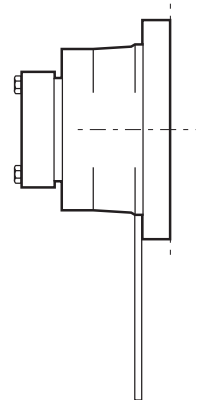
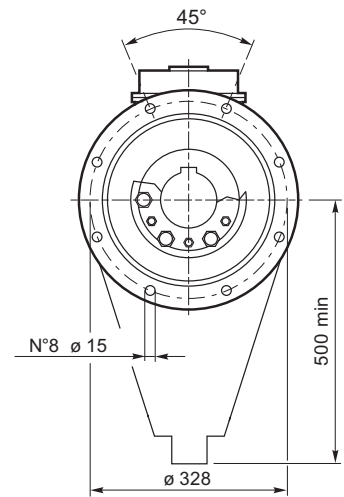
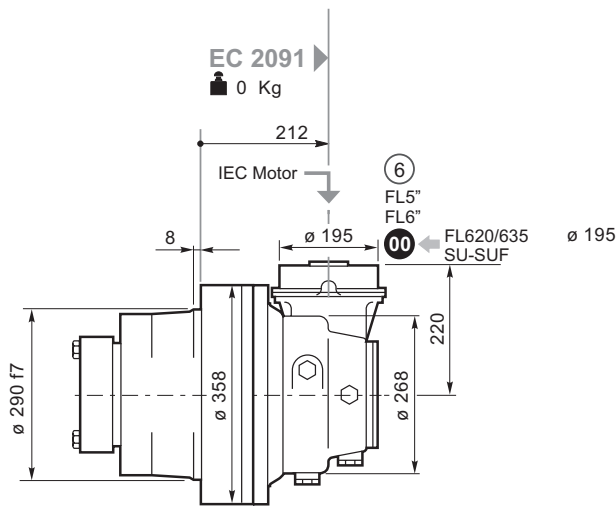
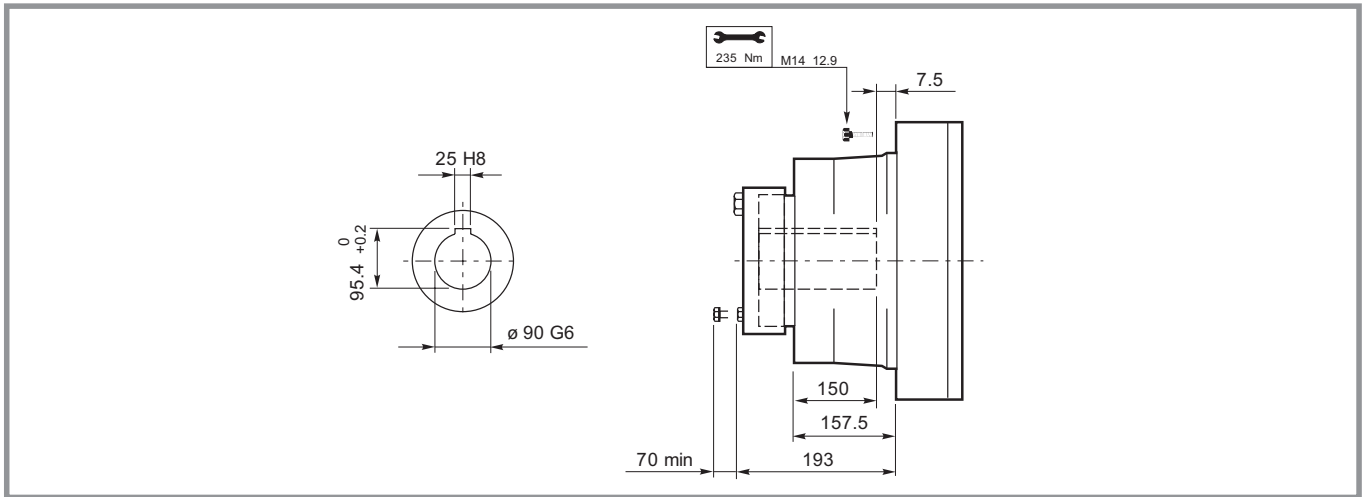

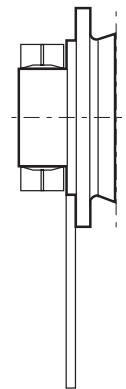
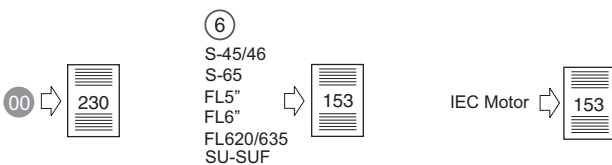
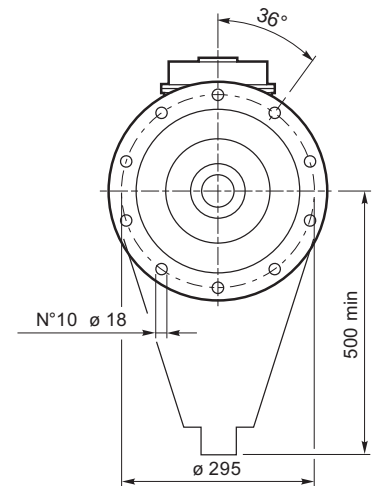
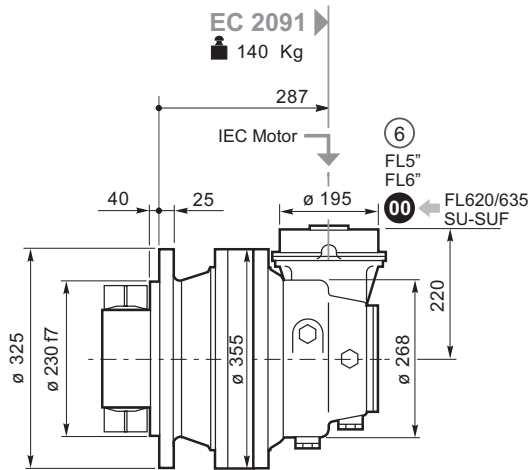
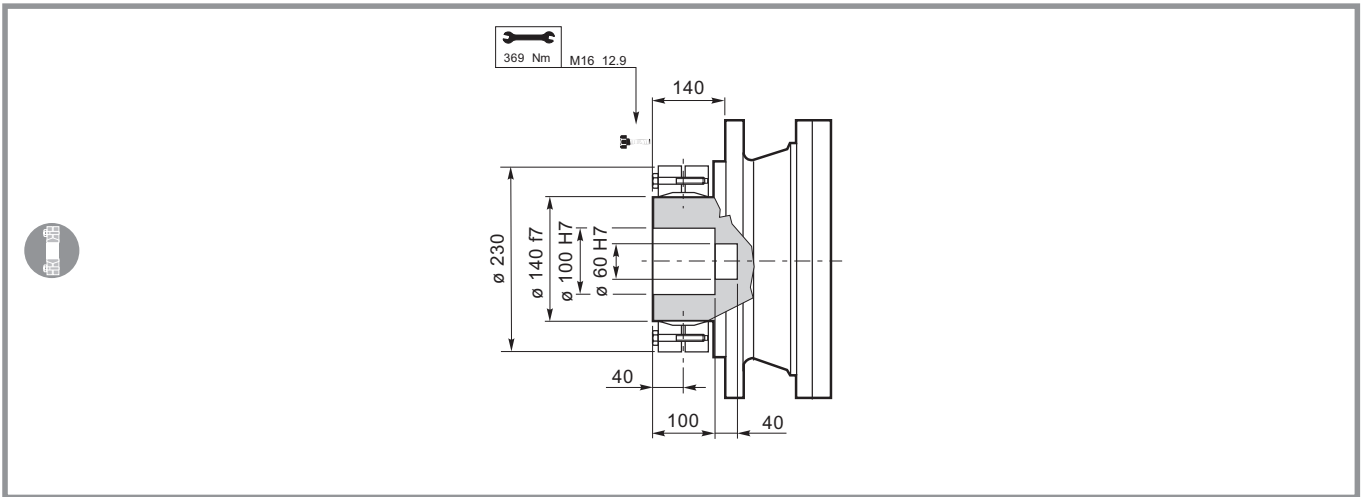

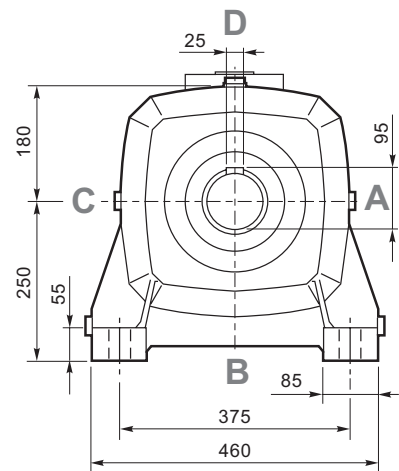
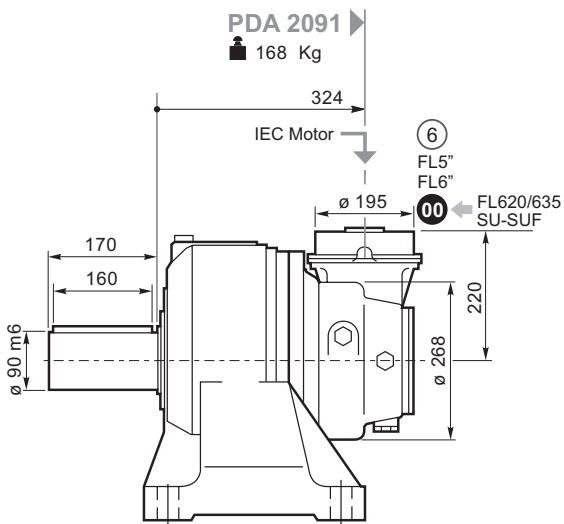
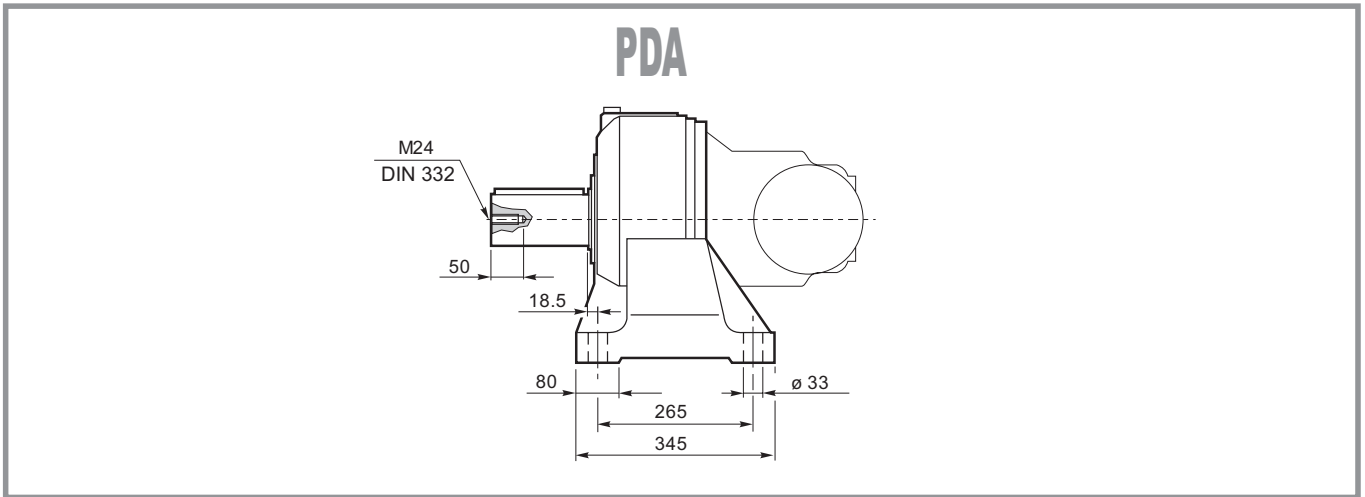

## ⑥ 48.82

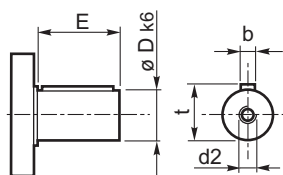

48.82	D	E	EC 2091	Lt	
				MN-MN1-MR-MR1-FS-FP-FE-PDA	317
	48	82			

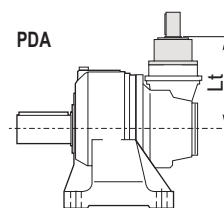

## FL250-FL350-FL450 FL750

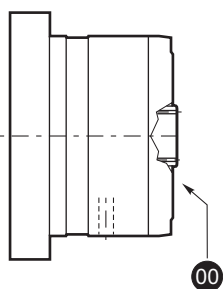

FL250 FL350 FL450 FL750	EC 2091	Lt			
		MN-MN1 FE-FS	MR-MR1	FP	PD-PDA
		408	408	408	408
		422	422	422	422

FL620/10  
FL635/10

FL620U-FL635U

SAE A-AA  
Shaft FE

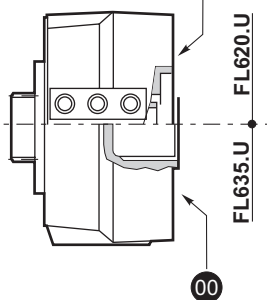

FL620/U FL635U	EC 2091	Lt			
		MN-MN1 FE-FS	MR-MR1	FP	PD
		324.5	324.5	324.5	324.5
		311	311	311	311
		317	317	317	317

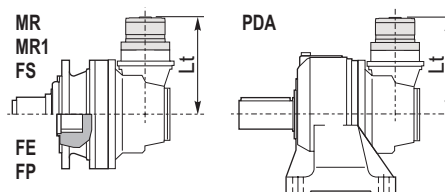

## IEC Motor

EC 2091	MN-MR-MN1-MR1 FE-FS-FP-PDA	Lt							
		IEC 63	IEC 71	IEC 80 90	IEC 100 112	IEC 132	IEC 160 180	IEC 200	IEC 225
		277	279	264	285	352	383	394	

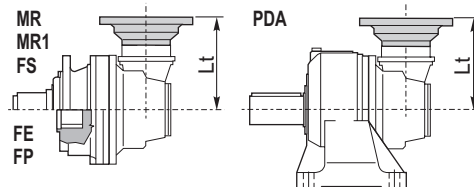





**Flangia ruota**  
Driving flange  
Radnabenflansch  
Flasque de roue  
Brida de la rueda  
Flange de roda

**FA 090**

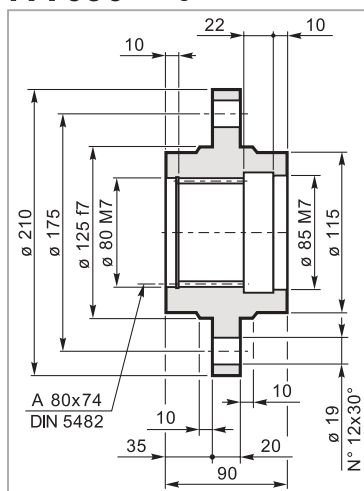

Mat. C40 UNI EN 10083  
Code: 34701521800



**Flangia ruota**  
Driving flange  
Radnabenflansch  
Flasque de roue  
Brida de la rueda  
Flange de roda

**FR 090**

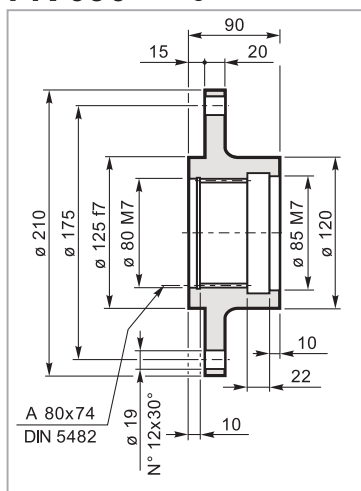

Mat. C40 UNI EN 10083  
Code: 34701421800



**Pignoni**  
Pinion  
Ritzel  
Pignon  
Piñones  
Pinhões

**IR 090**

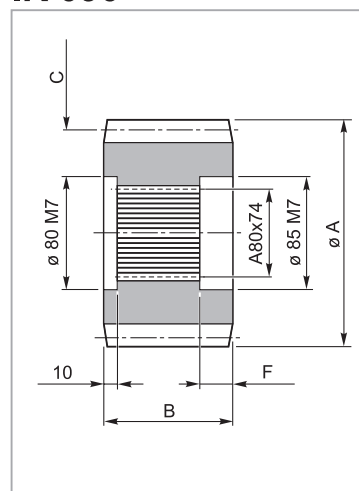

code	A	B	C	F
335.3543.0600	159	90	M=10 Z=13 X=0.5	31



**Manicotto scanalato**  
Splined bush  
Keilmuffe  
Manchon cannelée  
Manguito acanalado  
Luva ranhurada

**MS 090**

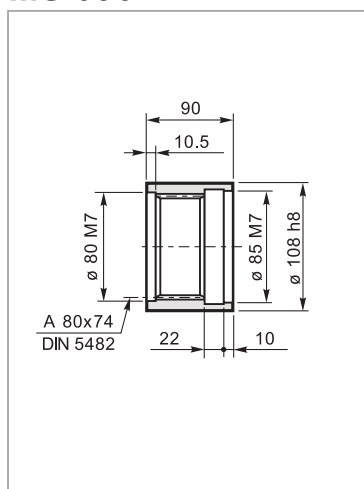

Mat. 39NiCrMo3 UNI EN 10083  
Code: 39103040600



**Rondella di fermo**  
Shaft cover  
Gegenscheibe  
Rondelle frein  
Arandela de bloqueo  
Amuela de encosto

**RDF 090**

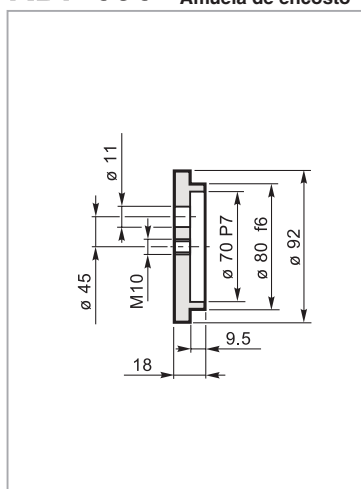

Mat. C40 UNI EN 10083  
Code: 37200940800



**Barra scanalata**  
Splined bar  
Zugspindel  
Barre cannelée  
Barra acanalada  
Barra ranhurada

**BS 090**

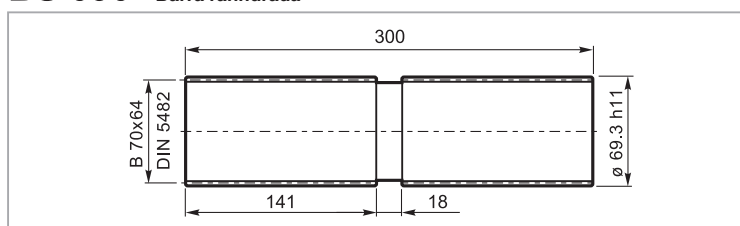

Mat. 39NiCrMo3 UNI EN 10083  
Code: 39127130100

Carichi radiali sugli alberi uscita / Radial loads on output shafts  
 Radiallasten auf de Abtriebswellen / Charges radiales sur les arbres de sortie

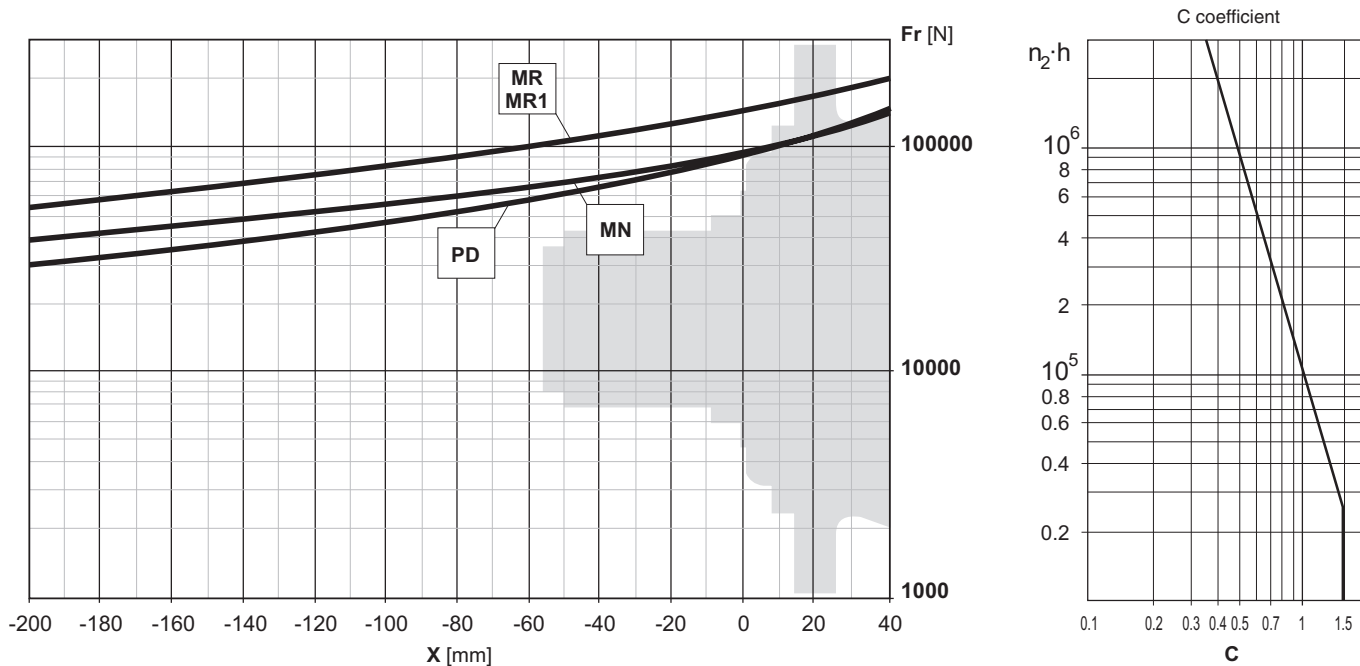

Carichi assiali / Axial loads / Axialkräfte / Charges axiales / Cargas axiales / Forças axiais

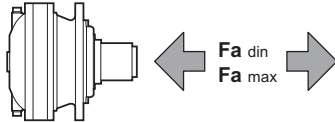

		Flange mounted		PD-PDA
		MN-MN1	MR-MR1	MR1
<b>Fa<sub>din</sub></b>	[N]	48000	80000	35000
<b>Fa<sub>max</sub></b>	[N]	60000	90000	35000

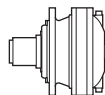

i <sub>eff</sub>	1500			1000			500			T <sub>2max</sub> [Nm]	P <sub>T</sub> [kW]	
	n <sub>2</sub> [rpm]	T <sub>2</sub> [Nm]	P <sub>2</sub> [kW]	n <sub>2</sub> [rpm]	T <sub>2</sub> [Nm]	P <sub>2</sub> [kW]	n <sub>2</sub> [rpm]	T <sub>2</sub> [Nm]	P <sub>2</sub> [kW]			
<b>EM 1150</b>												
3.90	385	4758	192	256	5374	144	128	6616	89	20000	40	
5.14	292	5006	153	195	5654	115	97	6961	71	20000		
6.27	239	5178	130	159	5847	98	80	7199	60	20000		
<b>ED 2150</b>												
13.65	110	6103	70	73	6893	53	36.6	8486	32.6	20000	23	
16.11	93	6309	62	62	7125	46.3	31.0	8772	28.5	20000		
17.99	83	7290	64	56	8233	47.9	27.8	9317	27.1	20000		
20.16	74	6563	51	50	7412	38.5	24.8	9125	23.7	20000		
21.95	68	7540	54	45.6	8220	39.2	22.8	8771	20.9	20000		
26.57	56	8195	48.4	37.6	9057	35.7	18.8	9649	19.0	20000		
28.28	53	6170	34.3	35.4	6613	24.5	17.7	7286	13.5	20000		
30.84	48.6	8570	43.7	32.4	9185	31.2	16.2	9776	16.6	20000		
37.27	40.3	8132	34.3	26.8	8716	24.5	13.4	9603	13.5	20000		
45.46	33.0	8477	29.3	22.0	8799	20.3	11.0	9353	10.8	20000		
<b>ET 3150</b>												
47.78	31.4	8888	29.2	20.9	10037	22.0	10.5	12357	13.5	20000	15	
56.37	26.6	9340	26.0	17.7	10548	19.6	8.9	12986	12.1	20000		
62.96	23.8	9448	23.6	15.9	9794	16.3	7.9	10392	8.6	20000		
70.57	21.3	9991	22.2	14.2	11283	16.7	7.1	13892	10.3	20000		
81.90	18.3	10447	20.0	12.2	11799	15.1	6.1	14526	9.3	20000		
93.01	16.1	9781	16.5	10.8	10129	11.4	5.4	11021	6.2	20000		
98.96	15.2	11058	17.6	10.1	12488	13.2	5.1	13856	7.3	20000		
107.9	13.9	9908	14.4	9.3	10258	10.0	4.6	11354	5.5	20000		
127.4	11.8	10050	12.4	7.9	10402	8.6	3.9	11733	4.8	20000		
137.4	10.9	10115	11.6	7.3	10468	8.0	3.6	11910	4.5	20000		
159.4	9.4	10244	10.1	6.3	10684	7.0	3.1	12263	4.0	20000		
185.0	8.1	10374	8.8	5.4	11010	6.2	2.7	12623	3.6	20000		
192.7	7.8	10409	8.5	5.2	11099	6.0	2.6	12722	3.5	20000		
223.6	6.7	10539	7.4	4.5	11434	5.4	2.2	13093	3.1	20000		
235.0	6.4	9797	6.5	4.3	10399	4.6	2.1	11934	2.7	20000		
270.2	5.6	10643	6.2	3.7	11112	4.3	1.9	11921	2.3	20000		
329.6	4.6	10258	4.9	3.0	11128	3.5	1.5	12743	2.0	20000		
<b>EQ 4150</b>												
359.5	4.2	15642	6.8	2.8	16279	4.7	1.4	18842	2.7	20000		11
391.2	3.8	15764	6.3	2.6	16578	4.4	1.3	19172	2.6	20000		
461.7	3.2	14336	4.9	2.2	14970	3.4	1.1	17336	2.0	20000		
491.4	3.1	16094	5.1	2.0	17403	3.7	1.0	19575	2.1	20000		
568.4	2.6	16464	4.6	1.8	17944	3.3	0.88	19845	1.8	20000		
645.5	2.3	12997	3.2	1.5	14044	2.3	0.77	15988	1.3	20000		
700.7	2.1	15008	3.4	1.4	16365	2.4	0.71	18879	1.4	20000		
810.4	1.9	15486	3.0	1.2	16872	2.2	0.62	19271	1.2	20000		
883.9	1.7	13803	2.5	1.1	14900	1.8	0.57	16938	1.0	20000		
1039	1.4	15905	2.4	0.96	16561	1.7	0.48	17700	0.89	20000		
1110	1.4	14412	2.0	0.90	15418	1.5	0.45	17656	0.83	20000		
1226	1.2	16903	2.2	0.82	18375	1.6	0.41	19586	0.84	20000		
1342	1.1	14755	1.7	0.75	16075	1.3	0.37	18272	0.71	20000		
1552	0.97	15177	1.5	0.64	16539	1.1	0.32	18757	0.63	20000		
1875	0.80	13067	1.1	0.53	14330	0.80	0.27	16674	0.47	20000		
2023	0.74	16117	1.3	0.49	17360	0.90	0.25	19669	0.51	20000		
2348	0.64	16565	1.1	0.43	17836	0.80	0.21	20197	0.45	20000		
2468	0.61	15148	0.96	0.41	16325	0.69	0.20	18512	0.39	20000		
2837	0.53	14358	0.80	0.35	15701	0.58	0.18	18194	0.34	20000		
3460	0.43	16125	0.73	0.29	17364	0.53	0.14	19665	0.30	20000		

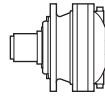

$i_{eff}$	1500			1000			500			$T_{2max}$ [Nm]	$P_T$ [kW]	
	$n_2$ [rpm]	$T_2$ [Nm]	$P_2$ [kW]	$n_2$ [rpm]	$T_2$ [Nm]	$P_2$ [kW]	$n_2$ [rpm]	$T_2$ [Nm]	$P_2$ [kW]			
<b>EM 1150</b>												
3.90	385	8407	339	256	9494	255	128	11689	157	20000	40	
5.14	292	8376	256	195	8905	181	97	9679	99	20000		
6.27	239	8045	202	159	8487	142	80	9162	77	20000		
<b>ED 2150</b>												
13.65	110	10783	124	73	12178	93	36.6	14716	56	20000	23	
16.11	93	11147	109	62	12138	79	31.0	13452	43.7	20000		
17.99	83	9838	86	56	10241	60	27.8	11540	33.6	20000		
20.16	74	9403	73	49.6	10112	53	24.8	11134	28.9	20000		
21.95	68	9303	67	45.6	9669	46.1	22.8	10831	25.8	20000		
26.57	56	10226	60	37.6	10840	42.7	18.8	12479	24.6	20000		
28.28	53	7619	42.3	35.4	8102	30.0	17.7	8841	16.4	20000		
30.84	48.6	10371	53	32.4	11181	38.0	16.2	12851	21.8	20000		
37.27	40.3	10042	42.3	26.8	10678	30.0	13.4	11652	16.4	20000		
45.46	33.0	10032	34.7	22.0	10909	25.1	11.0	12521	14.4	20000		
<b>ET 3150</b>												
47.78	31.4	15012	49.4	20.9	15748	34.5	10.5	18220	20.0	20000	15	
56.37	26.6	15320	42.7	17.7	16176	30.0	8.9	18882	17.5	20000		
62.96	23.8	11905	29.7	15.9	12903	21.5	7.9	14741	12.3	20000		
70.57	21.3	15721	35.0	14.2	17035	25.3	7.1	19800	14.7	20000		
81.90	18.3	16055	30.8	12.2	17613	22.5	6.1	19402	12.4	20000		
93.01	16.1	12864	21.7	10.8	13915	15.7	5.4	15858	8.9	20000		
98.96	15.2	14449	22.9	10.1	15342	16.2	5.1	16706	8.8	20000		
107.9	13.9	13243	19.3	9.3	14316	13.9	4.6	16302	7.9	20000		
127.4	11.8	13674	16.9	7.9	14773	12.1	3.9	16806	6.9	20000		
137.4	10.9	13874	15.9	7.3	14985	11.4	3.6	17041	6.5	20000		
159.4	9.4	14275	14.1	6.3	15409	10.1	3.1	17511	5.8	20000		
185.0	8.1	14512	12.3	5.4	15694	8.9	2.7	17991	5.1	20000		
192.7	7.8	14796	12.1	5.2	15962	8.7	2.6	18123	4.9	20000		
223.6	6.7	14934	10.5	4.5	16376	7.7	2.2	18617	4.4	20000		
235.0	6.4	13902	9.3	4.3	15004	6.7	2.1	17050	3.8	20000		
270.2	5.6	12875	7.5	3.7	14154	5.5	1.9	16507	3.2	20000		
329.6	4.6	14817	7.1	3.0	15976	5.1	1.5	18127	2.9	20000		
<b>EQ 4150</b>												
359.5	4.2	20227	8.8	2.8	21077	6.1	1.4	23216	3.4	20000		11
391.2	3.8	21081	8.5	2.6	21320	5.7	1.3	23496	3.1	20000		
461.7	3.2	19343	6.6	2.2	20205	4.6	1.1	22310	2.5	20000		
491.4	3.1	20884	6.7	2.0	21985	4.7	1.0	24265	2.6	20000		
568.4	2.6	21263	5.9	1.8	22450	4.1	0.88	24765	2.3	20000		
645.5	2.3	18488	4.5	1.5	19883	3.2	0.77	22472	1.8	20000		
700.7	2.1	20240	4.5	1.4	21453	3.2	0.71	23656	1.8	20000		
810.4	1.9	20669	4.0	1.2	21902	2.8	0.62	24140	1.6	20000		
883.9	1.7	19562	3.5	1.1	21024	2.5	0.57	23739	1.4	20000		
1039	1.4	20034	3.0	0.96	21902	2.2	0.48	24984	1.3	20000		
1110	1.4	20373	2.9	0.90	21886	2.1	0.45	24696	1.2	20000		
1226	1.2	21929	2.8	0.82	23218	2.0	0.41	25561	1.1	20000		
1342	1.1	21068	2.5	0.75	22624	1.8	0.37	25515	1.0	20000		
1552	0.97	21615	2.2	0.64	23206	1.6	0.32	26162	0.88	20000		
1875	0.80	19683	1.6	0.53	21365	1.2	0.27	24486	0.68	20000		
2023	0.74	22645	1.8	0.49	24301	1.3	0.25	27377	0.71	20000		
2348	0.64	23241	1.6	0.43	24935	1.1	0.21	28081	0.63	20000		
2468	0.61	21331	1.4	0.41	22899	0.97	0.20	25813	0.55	20000		
2837	0.53	21402	1.2	0.35	23190	0.86	0.18	26512	0.49	20000		
3460	0.43	22632	1.0	0.29	24282	0.74	0.14	27349	0.41	20000		

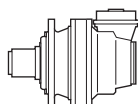

$i_{eff}$	1500			1000			500			$T_{2max}$ [Nm]	$P_T$ [kW]
	$n_2$ [rpm]	$T_2$ [Nm]	$P_2$ [kW]	$n_2$ [rpm]	$T_2$ [Nm]	$P_2$ [kW]	$n_2$ [rpm]	$T_2$ [Nm]	$P_2$ [kW]		

### EC 2150 - PDA 2150

10.73	140	4179	61	93	4719	46.1	46.6	5810	28.4	20000	18
14.14	106	5508	61	71	6220	46.1	35.4	7658	28.4	20000	
17.99	83	4041	35.3	56	4564	26.6	27.8	5619	16.4	20000	
18.99	79	3067	25.4	53	3463	19.1	26.3	4264	11.8	16483	
21.95	68	4929	35.3	45.6	5567	26.6	22.8	6854	16.4	20000	
25.03	60	4042	25.4	40.0	4565	19.1	20.0	5620	11.8	20000	
30.53	49.1	4931	25.4	32.8	5568	19.1	16.4	6856	11.8	20000	

### EC 2150 - PDA 3150

48.32	31.0	8772	28.5	20.7	9907	21.5	10.3	12197	13.2	20000	15
53.97	27.8	9317	27.1	18.5	9662	18.7	9.3	10258	10.0	20000	
63.06	23.8	6172	15.4	15.9	6970	11.6	7.9	8581	7.1	20000	
74.41	20.2	7283	15.4	13.4	8225	11.6	6.7	10126	7.1	20000	
83.11	18.0	8134	15.4	12.0	9186	11.6	6.0	10774	6.8	20000	
92.52	16.2	9776	16.6	10.8	10124	11.5	5.4	11010	6.2	20000	
98.07	15.3	9598	15.4	10.2	10175	10.9	5.1	11139	5.9	20000	
111.8	13.4	9603	13.5	8.9	10087	9.4	4.5	10893	5.1	20000	
122.8	12.2	10019	12.8	8.1	10369	8.8	4.1	11648	5.0	20000	
142.5	10.5	10147	11.2	7.0	10500	7.7	3.5	11995	4.4	20000	
149.8	10.0	9429	9.9	6.7	9760	6.8	3.3	10918	3.8	20000	
172.2	8.7	10118	9.2	5.8	10590	6.4	2.9	11394	3.5	20000	
210.0	7.1	9704	7.3	4.8	10164	5.1	2.4	11674	2.9	20000	

### EC 2150 - PDA 4150

260.5	5.8	14782	8.9	3.8	15762	6.3	1.9	17618	3.5	20000	10
296.9	5.1	13856	7.3	3.4	14532	5.1	1.7	15656	2.8	20000	
326.0	4.6	15501	7.5	3.1	16087	5.2	1.5	18465	3.0	20000	
350.3	4.3	13973	6.3	2.9	14507	4.3	1.4	16365	2.4	20000	
384.7	3.9	14096	5.8	2.6	14631	4.0	1.3	16690	2.3	20000	
457.2	3.3	14576	5.0	2.2	15235	3.5	1.1	16354	1.9	20000	
498.7	3.0	12363	3.9	2.0	13370	2.8	1.0	15240	1.6	20000	
555.1	2.7	12623	3.6	1.8	13647	2.6	0.90	15418	1.5	20000	
634.7	2.4	12955	3.2	1.6	13999	2.3	0.79	15938	1.3	20000	
711.0	2.1	13241	2.9	1.4	14303	2.1	0.70	16275	1.2	20000	
810.5	1.9	11921	2.3	1.2	12403	1.6	0.62	13868	0.90	20000	
890.1	1.7	13821	2.4	1.1	14920	1.8	0.56	16960	1.0	20000	
1033	1.5	14217	2.2	0.97	15172	1.5	0.48	17427	0.88	20000	
1086	1.4	12975	1.9	0.92	14015	1.4	0.46	15947	0.77	20000	
1248	1.2	12435	1.6	0.80	13063	1.1	0.40	15269	0.64	20000	
1523	0.99	13838	1.4	0.66	14932	1.0	0.33	16965	0.58	20000	

Tutti i rapporti evidenziati (es. 10.73) hanno dimensioni particolari della coppia conica in certe versioni; vedere tavole dimensionali.

All ratios grey highlighted (ex. 10.73) have specific dimensions of the bevel gear set in some versions; see dimensional tables.

Alle mit (es. 10.73) gekennzeichneten Übersetzungen haben in bestimmten Versionen besondere Dimensionen des Kegelradtriebs. Siehe auch Dimensionstabellen.

Les rapports repérés par (es. 10.73) ont des dimensions de couple conique particulières. Voir les tableaux dimensionnels.

Todas las relaciones indicadas con (es. 10.73) tienen dimensiones particulares del par cónico según las versiones; ver las tablas de dimensión.

As relações marcadas com (es. 10.73) têm dimensões particulares da engrenagem cônica em certas versões; vide tabelas dimensionais.



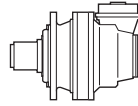

$i_{eff}$	1500			1000			500			$T_{2max}$ [Nm]	$P_T$ [kW]
	$n_2$ [rpm]	$T_2$ [Nm]	$P_2$ [kW]	$n_2$ [rpm]	$T_2$ [Nm]	$P_2$ [kW]	$n_2$ [rpm]	$T_2$ [Nm]	$P_2$ [kW]		

**EC 2150 - PDA 2150**

10.73	140	7383	108	93	8338	81	46.6	10266	50	20000	18
14.14	106	9588	107	71	10003	74	35.4	10981	40.7	20000	
17.99	83	7139	62	56	8063	46.9	27.8	9927	28.9	20000	
18.99	79	5419	44.8	53	6119	33.7	26.3	7119	19.6	16483	
21.95	68	8709	62	45.6	9669	46.1	22.8	10831	25.8	20000	
25.03	60	7141	44.8	40.0	8065	33.7	20.0	9382	19.6	20000	
30.53	49.1	8712	44.8	32.8	9838	33.7	16.4	11445	19.6	20000	

**EC 2150 - PDA 3150**

48.32	31.0	13452	43.7	20.7	14120	30.6	10.3	15938	17.3	20000	15
53.97	27.8	11540	33.6	18.5	12517	24.3	9.3	14316	13.9	20000	
63.06	23.8	10904	27.2	15.9	12315	20.5	7.9	15161	12.6	20000	
74.41	20.2	12867	27.2	13.4	14531	20.5	6.7	17503	12.3	20000	
83.11	18.0	12583	23.8	12.0	13618	17.2	6.0	15529	9.8	20000	
92.52	16.2	12851	21.8	10.8	13901	15.7	5.4	15694	8.9	20000	
98.07	15.3	12998	20.8	10.2	14057	15.0	5.1	16015	8.6	20000	
111.8	13.4	11652	16.4	8.9	12189	11.4	4.5	13549	6.3	20000	
122.8	12.2	13577	17.4	8.1	14670	12.5	4.1	16693	7.1	20000	
142.5	10.5	13971	15.4	7.0	14777	10.9	3.5	17155	6.3	20000	
149.8	10.0	12751	13.4	6.7	13783	9.6	3.3	15696	5.5	20000	
172.2	8.7	12224	11.2	5.8	12750	7.8	2.9	14952	4.5	20000	
210.0	7.1	13608	10.2	4.8	14692	7.3	2.4	16703	4.2	20000	

**PDA - EC 4150**

260.5	5.8	20669	12.5	3.8	21080	8.5	1.9	22171	4.5	20000	10
296.9	5.1	16706	8.8	3.4	17456	6.2	1.7	19349	3.4	20000	
326.0	4.6	20971	10.1	3.1	21213	6.8	1.5	22895	3.7	20000	
350.3	4.3	19192	8.6	2.9	19413	5.8	1.4	21453	3.2	20000	
384.7	3.9	19244	7.9	2.6	19676	5.4	1.3	21741	3.0	20000	
457.2	3.3	17504	6.0	2.2	18238	4.2	1.1	21302	2.4	20000	
498.7	3.0	17644	5.6	2.0	18986	4.0	1.0	21477	2.3	20000	
555.1	2.7	17991	5.1	1.8	19354	3.7	0.90	21886	2.1	20000	
634.7	2.4	18433	4.6	1.6	19823	3.3	0.79	22406	1.8	20000	
711.0	2.1	18814	4.2	1.4	20228	3.0	0.70	22856	1.7	20000	
810.5	1.9	16507	3.2	1.2	17994	2.3	0.62	20749	1.3	20000	
890.1	1.7	19587	3.5	1.1	21050	2.5	0.56	23768	1.4	20000	
1033	1.5	20114	3.1	0.97	21610	2.2	0.48	24389	1.2	20000	
1086	1.4	18435	2.7	0.92	19821	1.9	0.46	22395	1.1	20000	
1248	1.2	18094	2.3	0.80	19677	1.7	0.40	22615	0.95	20000	
1523	0.99	19585	2.0	0.66	21043	1.4	0.33	23751	0.82	20000	

Tutti i rapporti evidenziati (es. 10.73) hanno dimensioni particolari della coppia conica in certe versioni; vedere tavole dimensionali.

All ratios grey highlighted (ex. 10.73) have specific dimensions of the bevel gear set in some versions; see dimensional tables.

Alle mit (es. 10.73) gekennzeichneten Übersetzungen haben in bestimmten Versionen besondere Dimensionen des Kegelradtriebs. Siehe auch Dimensionstabellen.

Les rapports repérés par (es. 10.73) ont des dimensions de couple conique particulières. Voir les tableaux dimensionnels.

Todas las relaciones indicadas con (es. 10.73) tienen dimensiones particulares del par cónico según las versiones; ver las tablas de dimensión.

As relações marcadas com (es. 10.73) têm dimensões particulares da engrenagem cônica em certas versões; vide tabelas dimensionais.



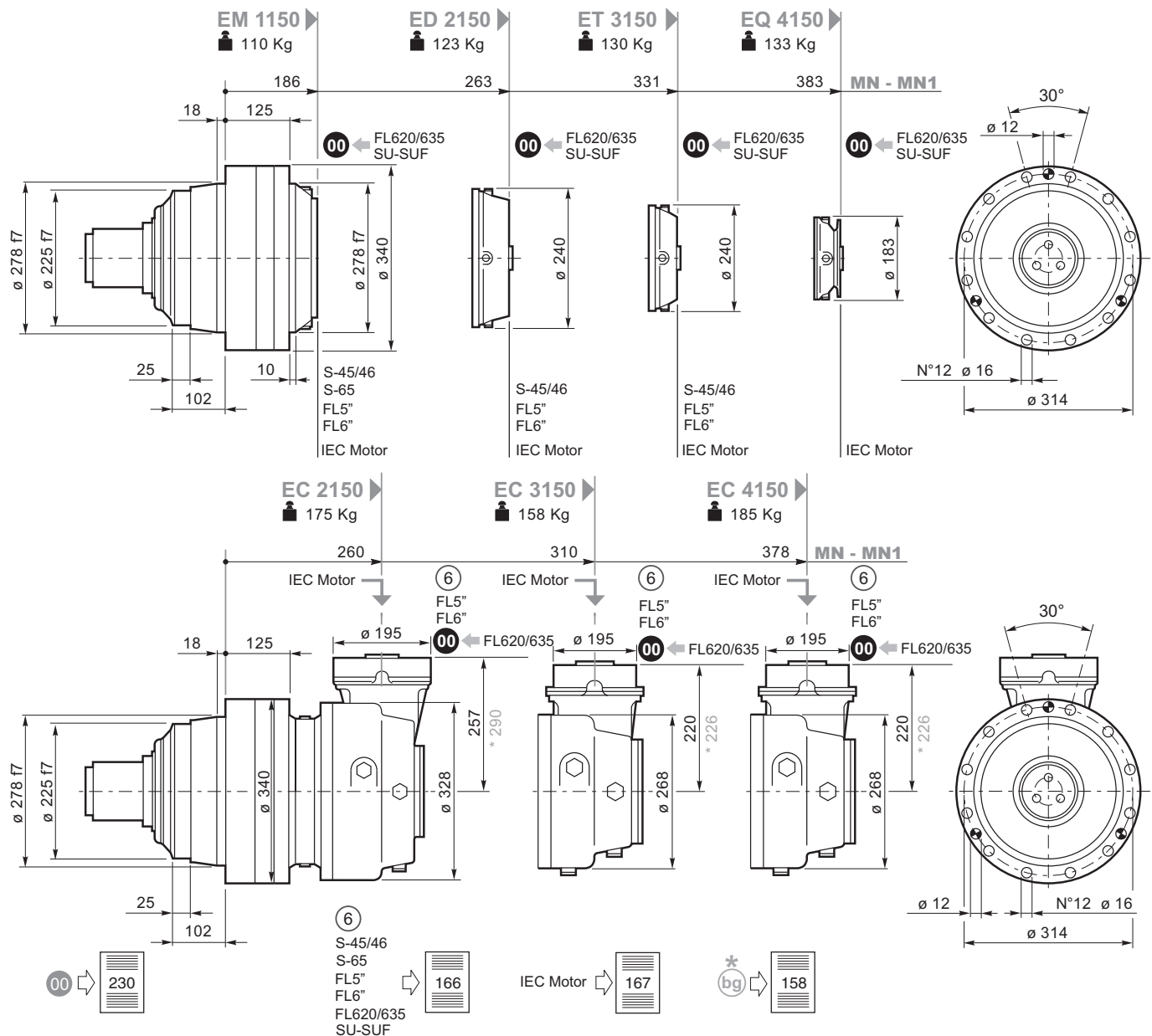
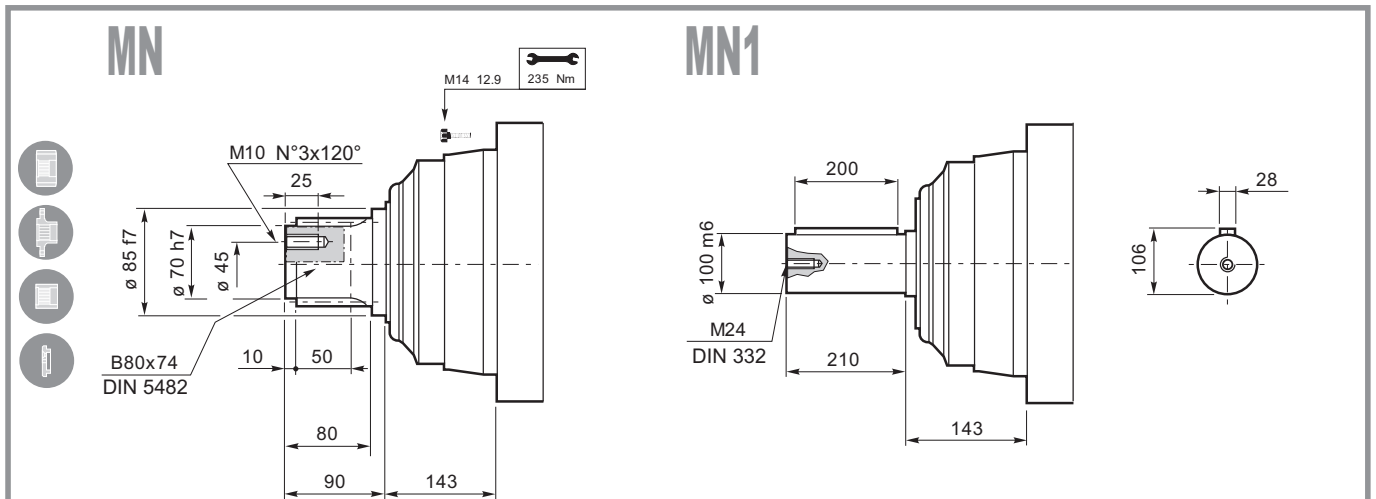

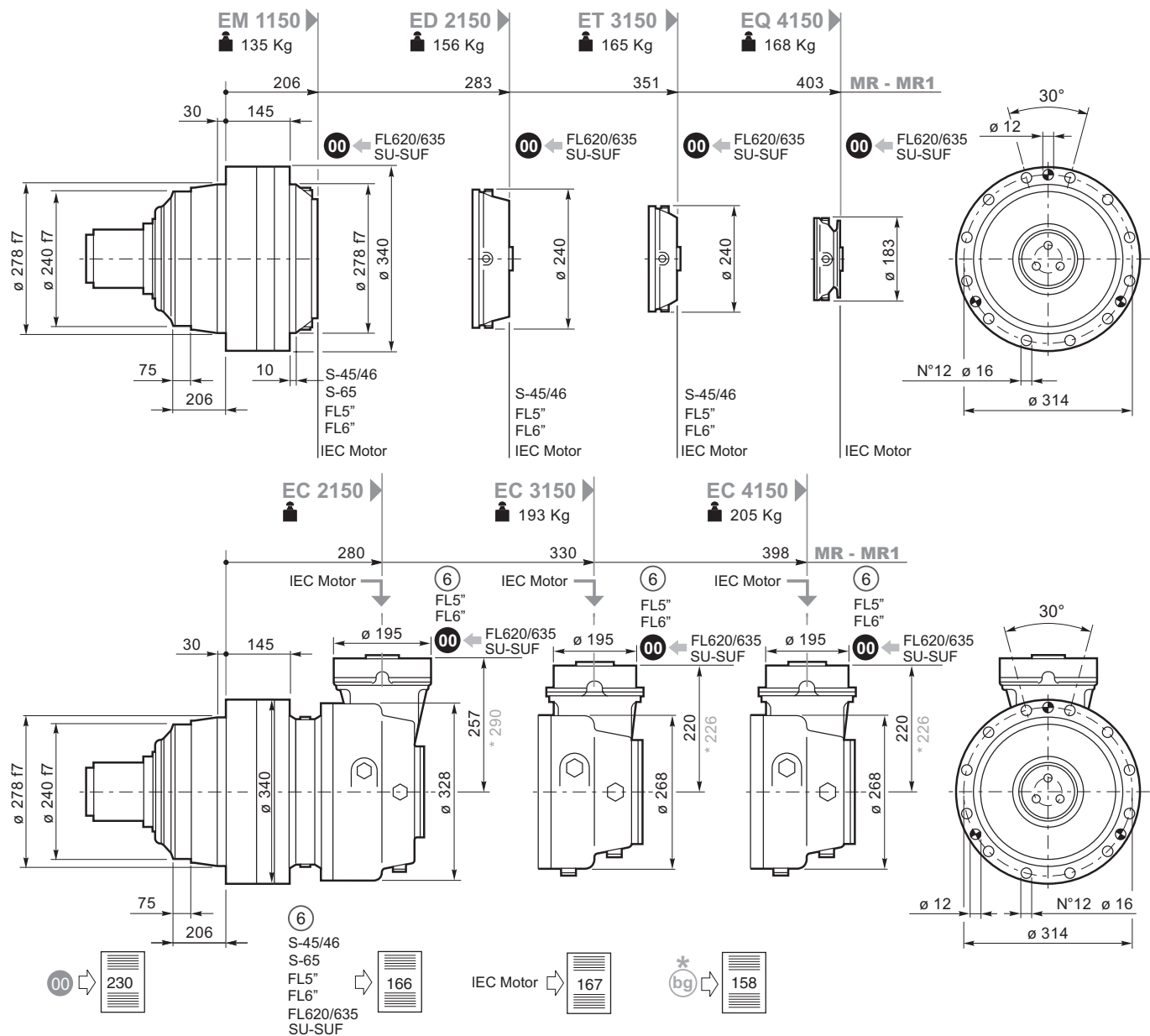
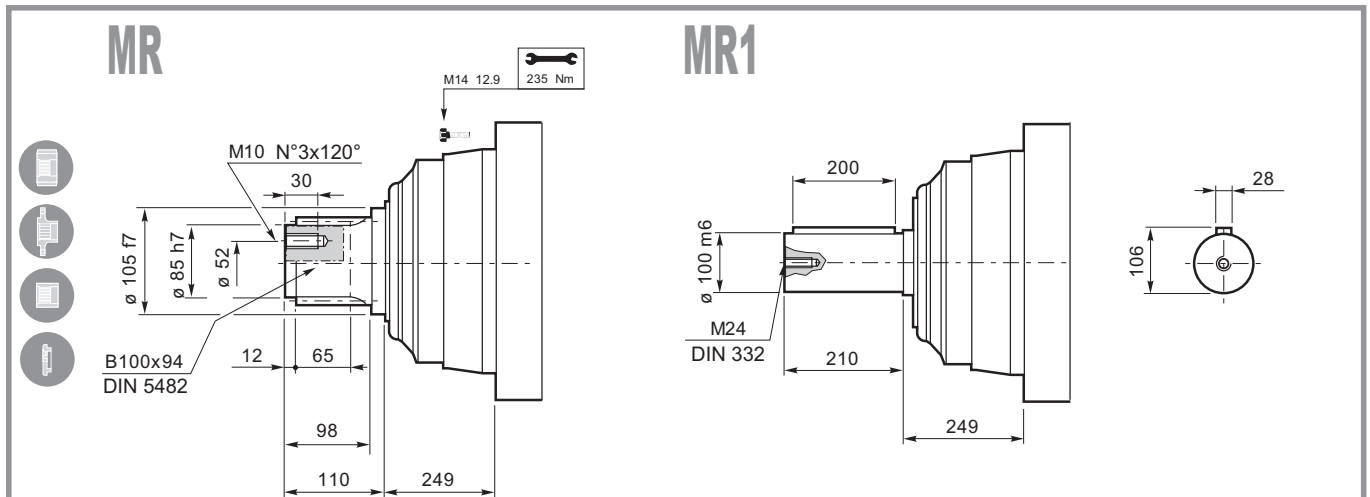



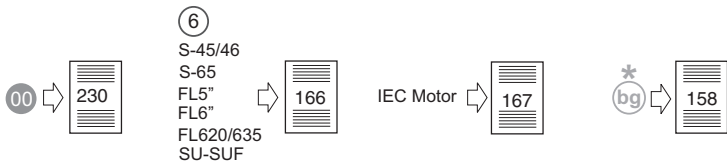
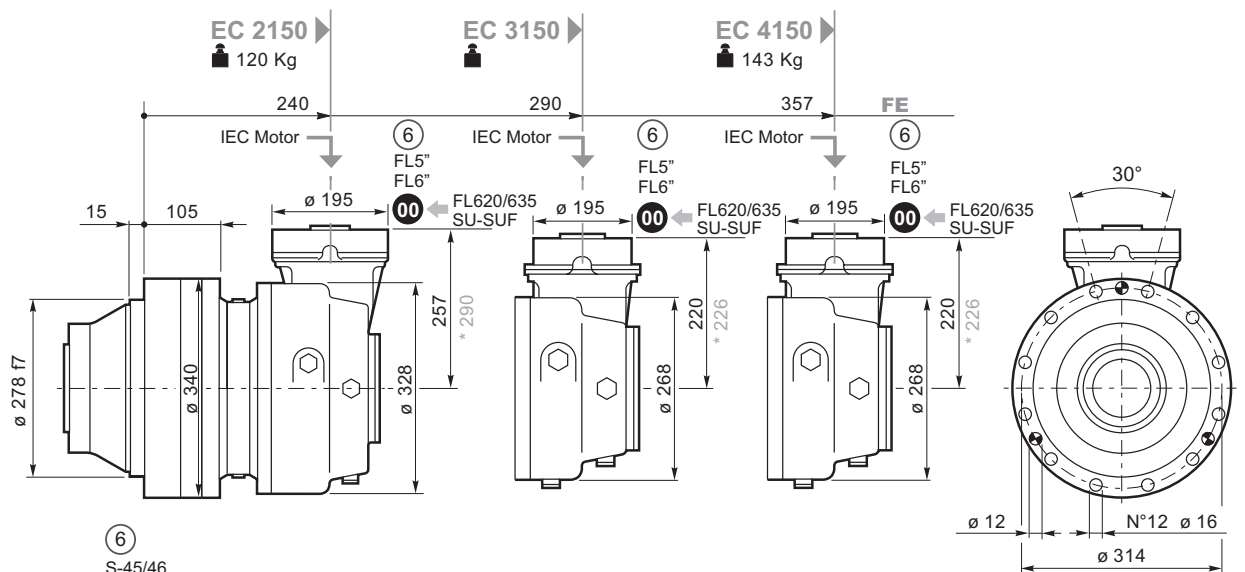
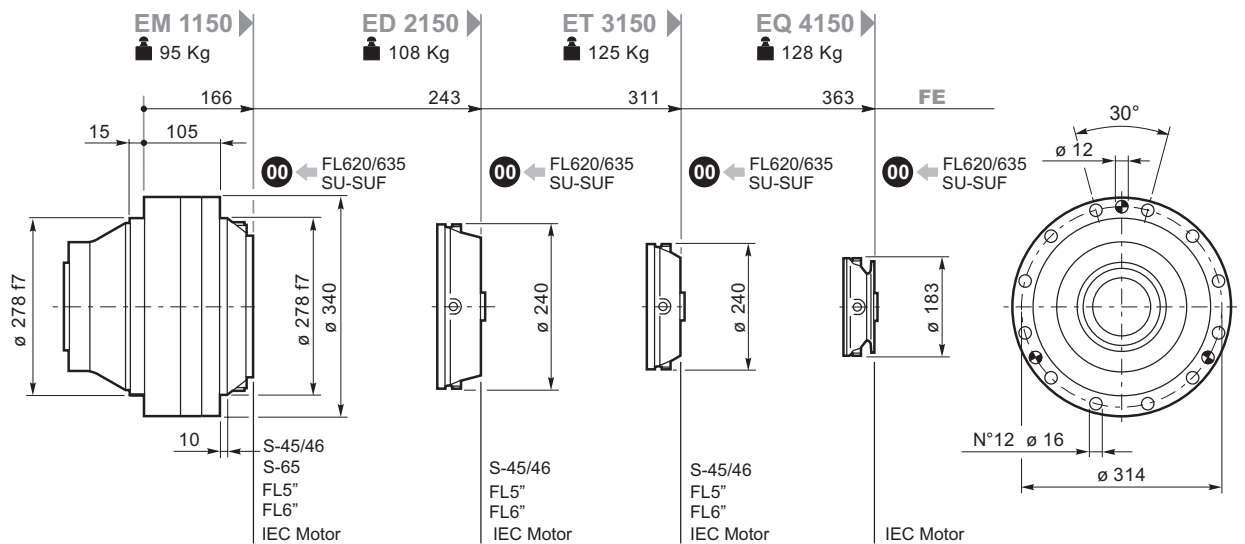
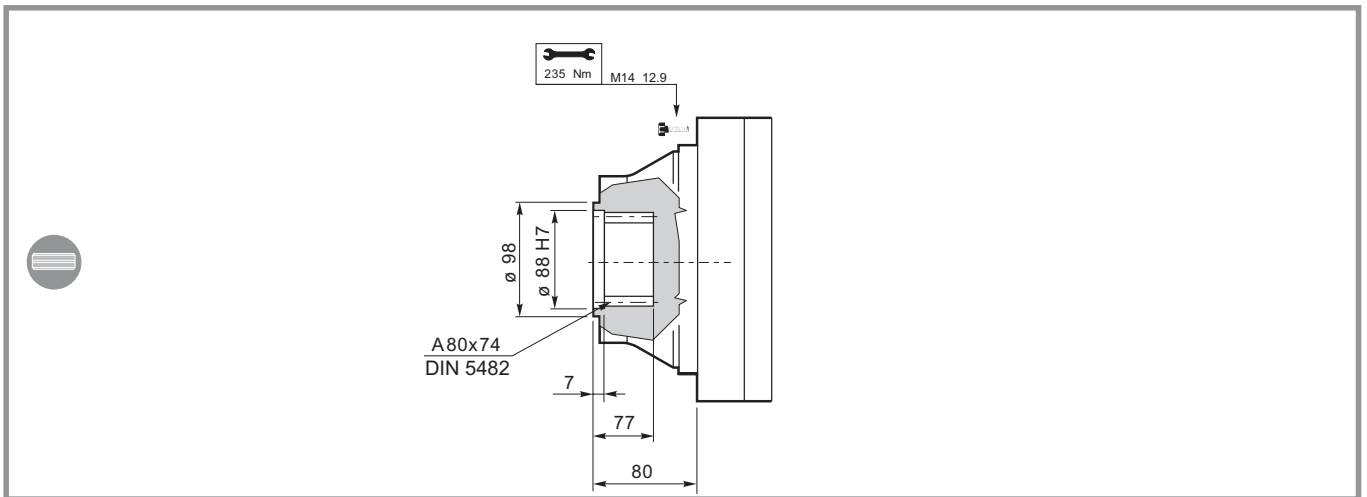

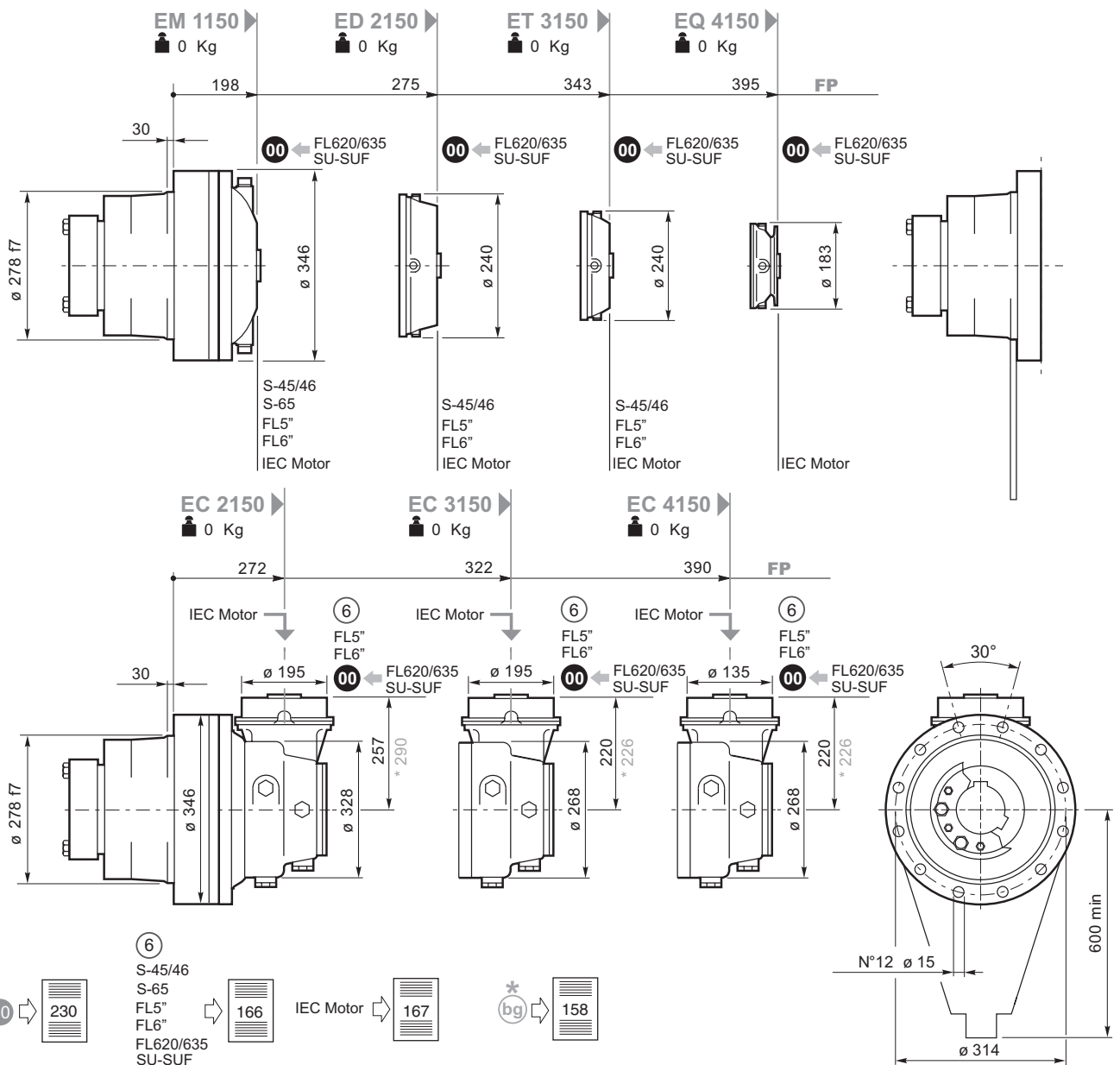
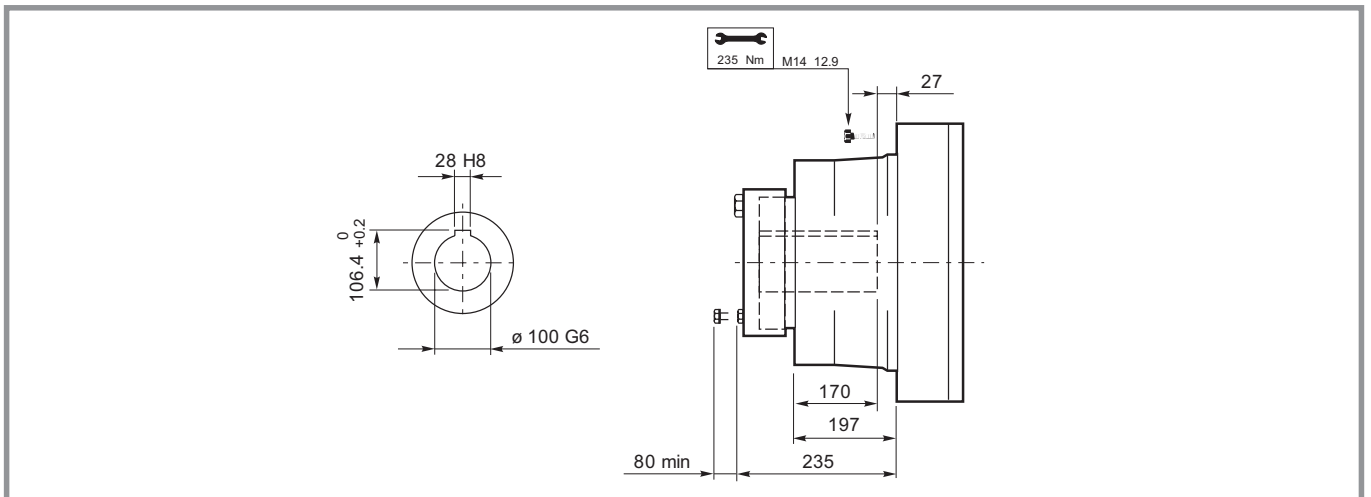

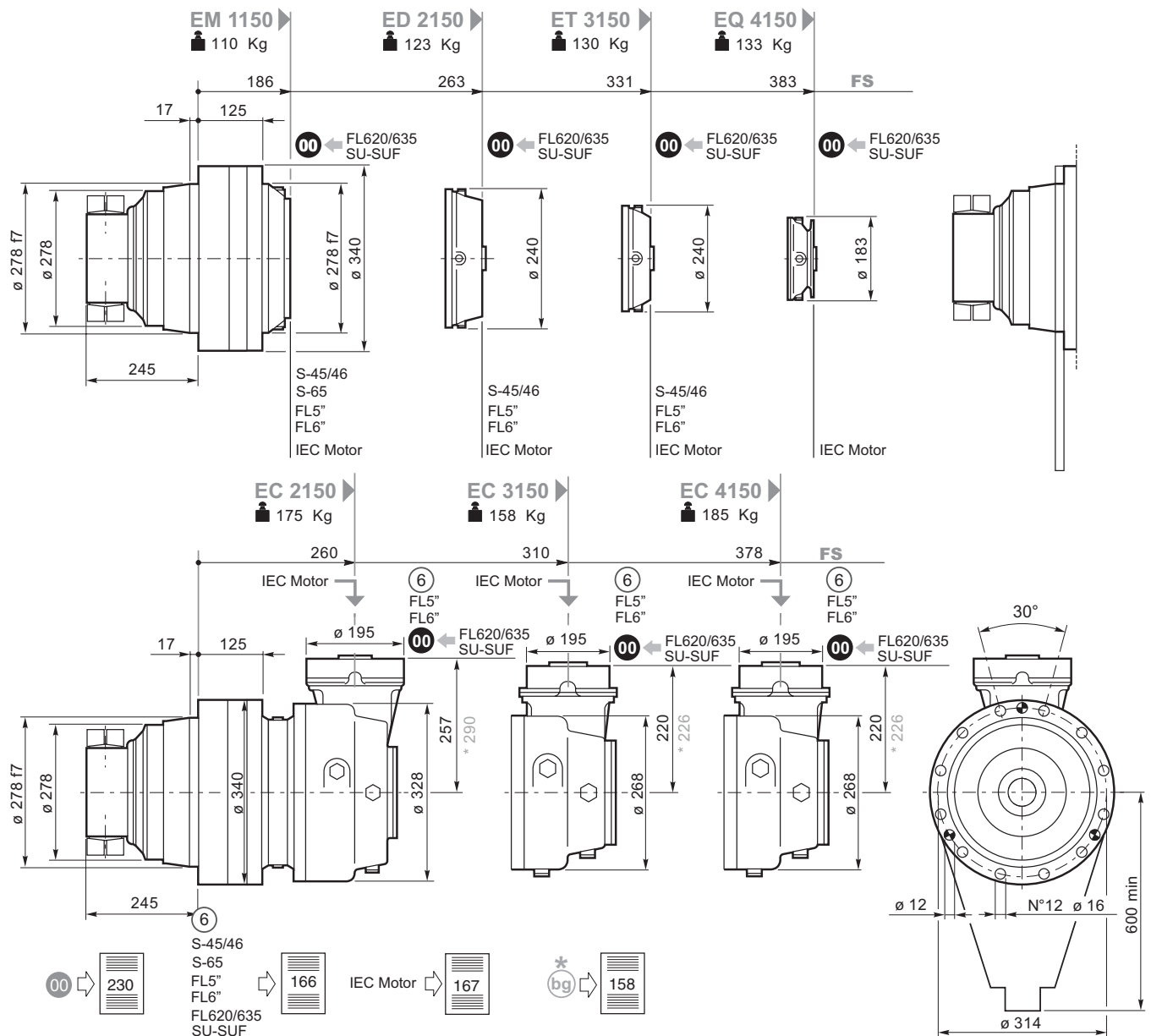
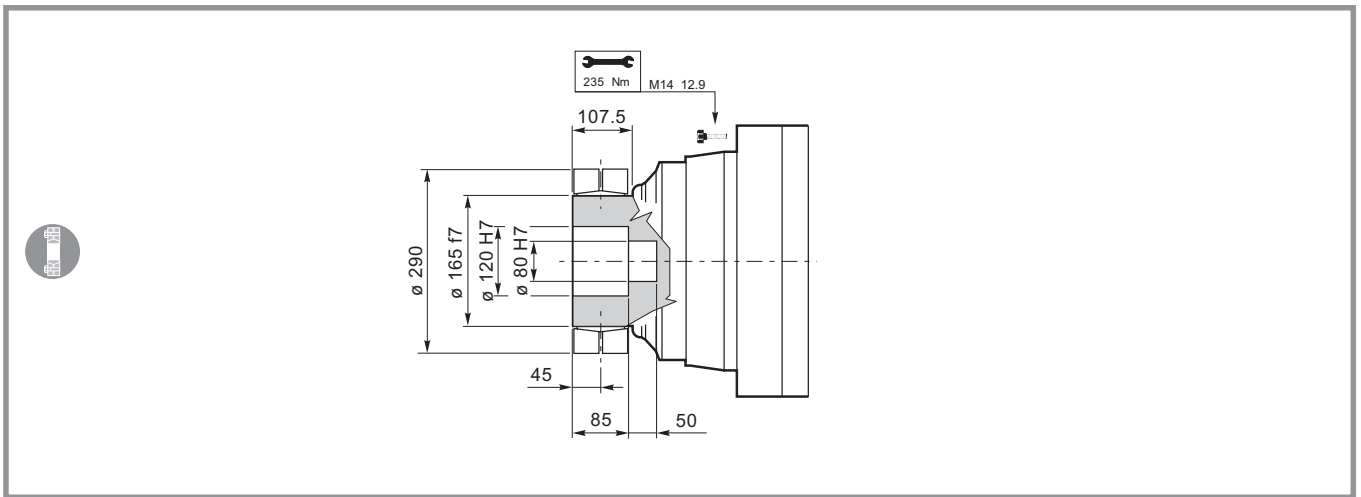



## S45CR1-S46C1

## S65CR1

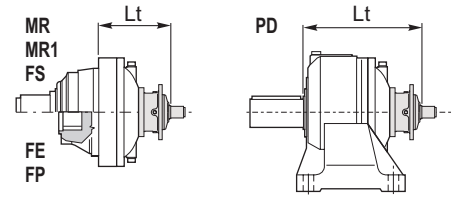
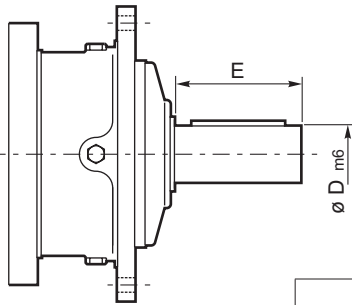

	D m6	E	Lt					
			MN-MN1-FS	MR-MR1	FE	FP	PD	
<b>S45 CR1</b>	65	105	<b>EM 1150</b>	326	346	306	338	468
			<b>ED 2150</b>	326	346	306	338	468
			<b>ET 3150</b>	393	413	373	405	535
<b>S46 C1</b>	65	105	<b>EM 1150</b>	346	387	347	379	510
			<b>ED 2150</b>	367	387	347	379	510
			<b>ET 3150</b>	434	454	414	446	577
<b>S65 CR1</b>	80	130	<b>EM 1150</b>	366	386	346	378	509

## SU2

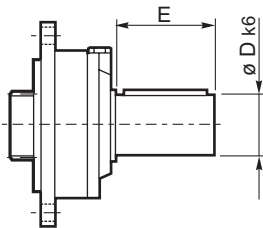

	D k6	E	Lt					
			MN MN1 FS	MR MR1	FE	FP	PD	
<b>SU 2</b>	40	58	<b>EM 1150</b>	246	266	226	258	—
			<b>ED 2150</b>	323	343	303	335	446
			<b>ET 3150</b>	391	411	371	403	533
			<b>EQ 4150</b>	443	463	423	455	596

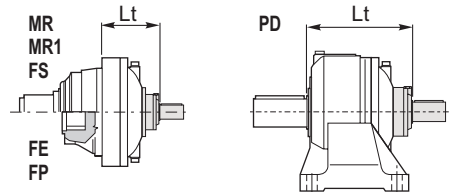

## ⑥ 48.82

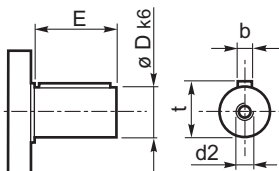

	D	E	Lt				
			MN-MN1-MR-MR1-FS-FE-FP-PDA				
<b>48.82</b>	48	82	<b>EC 2150</b>				317
			<b>EC 3150</b>				280
			<b>EC 4150</b>				280

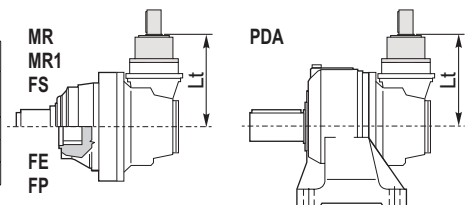

## FL250-FL350-FL450 FL750 FL760-FL960

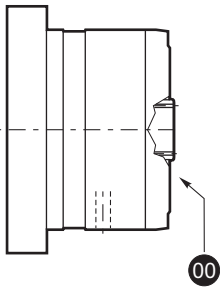

FL620/10  
FL635/10

FL620U-FL635U

SAE A-AA  
Shaft FE

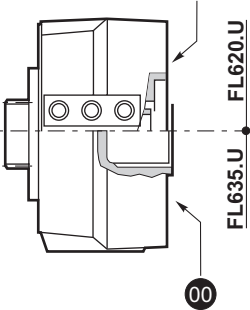

		Lt				
		MN-MN1 FS	MR-MR1	FE	FP	PD- PDA
FL250-FL350 FL450	EM 1150	296	316	276	308	439
	ED 2150	356	376	326	368	500
	ET 3150	424	444	404	436	567
	EC 2150*	408	408	408	408	408
	EC 2150	441	441	441	441	441
	EC 3150*	280	280	280	280	280
	EC 3150	377	377	377	377	377
	EC 4150*	280	280	280	280	280
	EC 4150	377	377	377	377	377
FL750	EM 1150	310	330	290	322	453
	ED 2150	370	390	350	382	513
	ET 3150	437	457	417	449	580
	EC 2150*	422	422	422	422	422
	EC 2150	455	455	455	455	455
FL760-FL960	EM 1150	324	344	304	336	467
	ED 2150	397	417	377	409	540

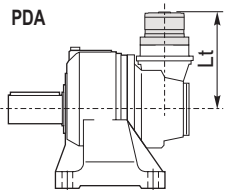
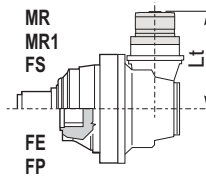
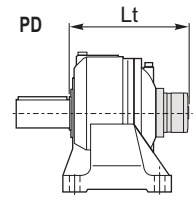
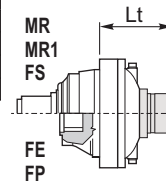

		Lt					
		MN-MN1 FS	MR-MR1	FE	FP	PD	
FL620/U	EM 1150	290.5	310.5	270.5	302.5	—	
	ED 2150	367.5	387.5	347.5	379.5	510.5	
	ET 3150	435.5	455.5	415.5	447.5	577.5	
	EQ 4150	487.5	507.5	467.5	499.5	640.5	
	EC 2150	361.5	361.5	361.5	361.5	361.5	
	EC 2150*	394.5	394.5	394.5	394.5	394.5	
	EC 3150	324.5	324.5	324.5	324.5	324.5	
	EC 3150*	330.5	330.5	330.5	330.5	330.5	
	EC 4150	324.5	324.5	324.5	324.5	324.5	
	EC 4150*	330.5	330.5	330.5	330.5	330.5	
	FL635U	EM 1150	277	297	257	289	—
		ED 2150	354	374	334	366	497
ET 3150		422	442	402	434	564	
EQ 4150		474	494	454	486	627	
EC 2150		348	348	348	348	348	
EC 2150*		381	381	381	381	381	
EC 3150		311	311	311	311	311	
EC 3150*		317	317	317	317	317	
EC 4150		311	311	311	311	311	
EC 4150*		317	317	317	317	317	
FL620/10		EQ 4150	446	466	426	446	590
FL635/10		EQ 4150	428	448	408	428	571

\* (bg) 158

## IEC Motor

		Lt							
		IEC 63	IEC 71	IEC 80 90	IEC 100 112	IEC 132	IEC 160 180	IEC 200	IEC 225
ED 2150	MN-MN-FS	283	285	290	291	358	389	399	430
ED 2150	MR-MR1	303	305	310	311	378	409	419	450
ED 2150	FE	263	265	270	271	338	369	379	410
ED 2150	FP								
ET 3150	MN-MN-FS	351	353	358	359	426	457	467	498
ET 3150	MR-MR1	371	373	378	379	446	447	487	518
ET 3150	FE	331	333	338	339	406	437	447	478
ET 3150	FP								
EQ 4150	MN-MN-FS	403	405	410	411	478			
EQ 4150	MR-MR1	423	425	430	431	498			
EQ 4150	FE	383	385	390	391	458			
EQ 4150	FP								
PD 2150	PD	426	428	433	434	501	532	542	573
PD 3150	PD	494	496	501	502	569	600	610	641
PD 4150	PD	546	548	553	554	621			
EC 2150	MN-MR-MN1-MR1 FE-FS-FP-PDA	277	279	284	285	352	383		
EC 2150*		310	312	317	318	385	416		
EC 3150		240	242	247	248	315	346		
EC 3150*		246	248	253	254	321	352		
EC 4150		240	242	247	248	315	346		
EC 4150*		246	248	253	254	321	352		

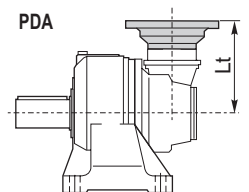
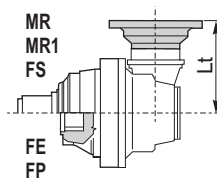
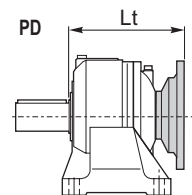
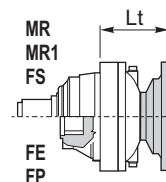



Carichi radiali sugli alberi uscita / Radial loads on output shafts  
 Radiallasten auf de Abtriebswellen / Charges radiales sur les arbres de sortie  
 Cargas sobre los ejes de salida / Cargas radiais nos eixos de saida

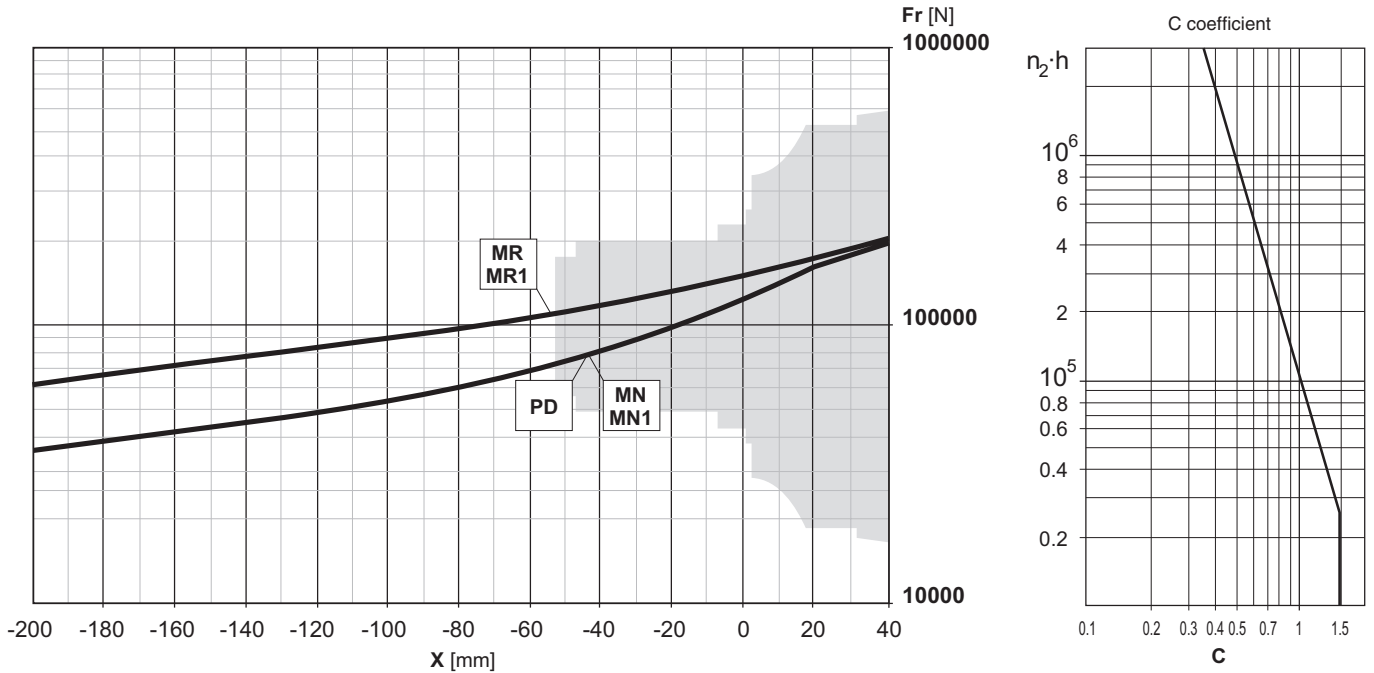

Carichi assiali / Axial loads / Axialkräfte / Charges axiales / Cargas axiales / Forças axiais

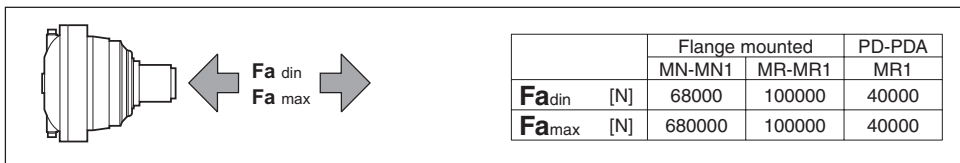

Carichi radiali sugli alberi entrata / Radial loads on input shafts  
 Radiallasten auf de Antriebswellen / Charges radiales sur les arbres d'entrée  
 Cargas sobre los ejes de entrada / Cargas radiais nos eixos de entrada

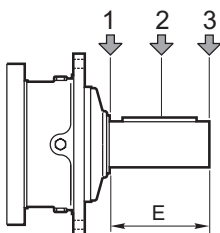

Type	E	$Fr$ [N]					
		$n_1 \cdot h = 10^7$			$n_1 \cdot h = 10^8$		
		1	2	3	1	2	3
S45 CR1	105	10000	6000	4000	5000	3000	2000
S46 C1	105	14000	8800	6400	7000	4400	3200
S65 CR1	130	23800	15500	9600	11900	7800	4800

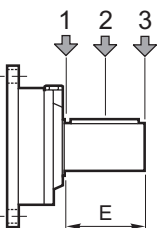

Type	E	$Fr$ [N]					
		$n_1 \cdot h = 10^7$			$n_1 \cdot h = 10^8$		
		1	2	3	1	2	3
SU2	58	3000	2000	1500	1400	1000	700



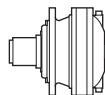

$i_{\text{eff}}$	1500			1000			500			$T_{2\text{max}}$ [Nm]	$P_T$ [kW]
	$n_2$ [rpm]	$T_2$ [Nm]	$P_2$ [kW]	$n_2$ [rpm]	$T_2$ [Nm]	$P_2$ [kW]	$n_2$ [rpm]	$T_2$ [Nm]	$P_2$ [kW]		
<b>ED 2155</b>											
19.50	77	7712	62	51	8709	46.8	25.6	10722	28.8	20000	23
23.40	64	8145	55	42.7	9199	41.2	21.4	11325	25.3	20000	
<b>ET 3155</b>											
47.78	31.4	10090	33.2	20.9	11395	25.0	10.5	13411	14.7	20000	15
56.37	26.6	10604	29.5	17.7	11976	22.2	8.9	13721	12.7	20000	
62.17	24.1	10920	27.6	16.1	12333	20.8	8.0	13992	11.8	20000	
70.57	21.3	11343	25.3	14.2	12810	19.0	7.1	14349	10.6	20000	
80.54	18.6	11802	23.0	12.4	13221	17.2	6.2	14727	9.6	20000	
87.31	17.2	12091	21.8	11.5	13310	16.0	5.7	14962	9.0	20000	
100.8	14.9	12624	19.7	9.9	13471	14.0	5.0	15388	8.0	20000	
109.1	13.7	12928	18.6	9.2	13631	13.1	4.6	15627	7.5	20000	
122.4	12.3	13236	17.0	8.2	13949	11.9	4.1	15978	6.8	20000	
141.4	10.6	13396	14.9	7.1	14353	10.6	3.5	16425	6.1	20000	
161.4	9.3	10255	10.0	6.2	10710	7.0	3.1	12291	4.0	20000	
169.7	8.8	13729	12.7	5.9	14878	9.2	2.9	17006	5.3	20000	
185.0	8.1	10374	8.8	5.4	11010	6.2	2.7	12623	3.6	20000	
196.8	7.6	9651	7.7	5.1	10030	5.3	2.5	11526	3.1	20000	
223.6	6.7	10539	7.4	4.5	11434	5.4	2.2	13093	3.1	20000	
272.7	5.5	9920	5.7	3.7	10715	4.1	1.8	12286	2.4	20000	

**1500**  
HOURS LIFE

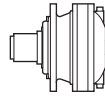

**155**

$i_{eff}$	1500			1000			500			$T_{2max}$ [Nm]	$P_T$ [kW]
	$n_2$ [rpm]	$T_2$ [Nm]	$P_2$ [kW]	$n_2$ [rpm]	$T_2$ [Nm]	$P_2$ [kW]	$n_2$ [rpm]	$T_2$ [Nm]	$P_2$ [kW]		
<b>ED 2155</b>											
<b>19.50</b>	77	13112	106	51	13988	75	25.6	16097	43.2	20000	23
<b>23.40</b>	64	13347	90	42.7	14527	65	21.4	16682	37.3	20000	
<b>ET 3155</b>											
<b>47.78</b>	31.4	15464	51	20.9	16748	36.7	10.5	19110	20.9	20000	15
<b>56.37</b>	26.6	15980	44.5	17.7	17292	32.1	8.9	19709	18.3	20000	
<b>62.17</b>	24.1	16291	41.2	16.1	17620	29.7	8.0	20070	16.9	20000	
<b>70.57</b>	21.3	16699	37.2	14.2	18050	26.8	7.1	20544	15.2	20000	
<b>80.54</b>	18.6	17131	33.4	12.4	18507	24.1	6.2	21048	13.7	20000	
<b>87.31</b>	17.2	17399	31.3	11.5	18790	22.5	5.7	21361	12.8	20000	
<b>100.8</b>	14.9	17884	27.9	9.9	19303	20.1	5.0	21928	11.4	20000	
<b>109.1</b>	13.7	18155	26.1	9.2	19590	18.8	4.6	22245	10.7	20000	
<b>122.4</b>	12.3	18553	23.8	8.2	20012	17.1	4.1	22712	9.7	20000	
<b>141.4</b>	10.6	19061	21.2	7.1	20550	15.2	3.5	23308	8.6	20000	
<b>161.4</b>	9.3	14307	13.9	6.2	15443	10.0	3.1	17549	5.7	20000	
<b>169.7</b>	8.8	18633	17.3	5.9	20396	12.6	2.9	23638	7.3	20000	
<b>185.0</b>	8.1	14684	12.5	5.4	15843	9.0	2.7	17991	5.1	20000	
<b>196.8</b>	7.6	13440	10.7	5.1	14514	7.7	2.5	16506	4.4	20000	
<b>223.6</b>	6.7	15216	10.7	4.5	16408	7.7	2.2	18617	4.4	20000	
<b>272.7</b>	5.5	14299	8.2	3.7	15426	5.9	1.8	17517	3.4	20000	

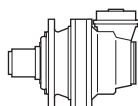

$i_{\text{eff}}$	1500			1000			500			$T_{2\text{max}}$ [Nm]	$P_T$ [kW]
	$n_2$ [rpm]	$T_2$ [Nm]	$P_2$ [kW]	$n_2$ [rpm]	$T_2$ [Nm]	$P_2$ [kW]	$n_2$ [rpm]	$T_2$ [Nm]	$P_2$ [kW]		

**EC 3155 - PDA 3155**

40.95	36.6	9235	35.4	24.4	10430	26.7	12.2	12841	16.4	20000	15
45.16	33.2	9921	34.5	22.1	11205	26.0	11.1	13348	15.5	20000	
50.66	29.6	10269	31.8	19.7	11598	24.0	9.9	13477	13.9	20000	
58.50	25.6	10722	28.8	17.1	12109	21.7	8.5	13823	12.4	20000	
63.06	23.8	6172	15.4	15.9	6970	11.6	7.9	8581	7.1	20000	
70.20	21.4	11325	25.3	14.2	12790	19.1	7.1	14334	10.7	20000	
78.02	19.2	7635	15.4	12.8	8623	11.6	6.4	10616	7.1	20000	
90.09	16.7	8817	15.4	11.1	9957	11.6	5.6	12259	7.1	20000	
102.8	14.6	9866	15.1	9.7	10215	10.4	4.9	11245	5.7	20000	
108.1	13.9	10580	15.4	9.3	11949	11.6	4.6	14711	7.1	20000	
118.7	12.6	9990	13.2	8.4	10340	9.1	4.2	11571	5.1	20000	
142.5	10.5	10147	11.2	7.0	10500	7.7	3.5	11995	4.4	20000	
173.8	8.6	9550	8.6	5.8	9883	6.0	2.9	11246	3.4	20000	

Tutti i rapporti evidenziati (es. 45.16) hanno dimensioni particolari della coppia conica in certe versioni; vedere tavole dimensionali.

All ratios grey highlighted (ex. 45.16) have specific dimensions of the bevel gear set in some versions; see dimensional tables.

Alle mit (es. 45.16) gekennzeichneten Übersetzungen haben in bestimmten Versionen besondere Dimensionen des Kegelradtriebs. Siehe auch Dimensionstabellen.

Les rapports repérés par (es. 45.16) ont des dimensions de couple conique particulières. Voir les tableaux dimensionnels.

Todas las relaciones indicadas con (es. 45.16) tienen dimensiones particulares del par cónico según las versiones; ver las tablas de dimensión.

As relações marcadas com (es. 45.16) têm dimensões particulares da engrenagem cônica em certas versões; vide tabelas dimensionais.



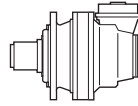

$i_{\text{eff}}$	1500			1000			500			$T_{2\text{max}}$ [Nm]	$P_T$ [kW]
	$n_2$ [rpm]	$T_2$ [Nm]	$P_2$ [kW]	$n_2$ [rpm]	$T_2$ [Nm]	$P_2$ [kW]	$n_2$ [rpm]	$T_2$ [Nm]	$P_2$ [kW]		

**EC 3155 - PDA 3155**

<b>40.95</b>	36.6	14992	58	24.4	16252	41.6	12.2	18565	23.7	20000	15
<b>45.16</b>	33.2	15290	53	22.1	16566	38.4	11.1	18910	21.9	20000	
<b>50.66</b>	29.6	15646	48.5	19.7	16940	35.0	9.9	19321	20.0	20000	
<b>58.50</b>	25.6	16097	43.2	17.1	17416	31.2	8.5	19845	17.8	20000	
<b>63.06</b>	23.8	10904	27.2	15.9	12315	20.5	7.9	15161	12.6	20000	
<b>70.20</b>	21.4	16682	37.3	14.2	17604	26.3	7.1	19562	14.6	20000	
<b>78.02</b>	19.2	13490	27.2	12.8	15235	20.5	6.4	18757	12.6	20000	
<b>90.09</b>	16.7	15578	27.2	11.1	17593	20.5	5.6	21483	12.5	20000	
<b>102.8</b>	14.6	13119	20.0	9.7	14185	14.4	4.9	16156	8.2	20000	
<b>108.1</b>	13.9	17652	25.6	9.3	18442	17.9	4.6	21496	10.4	20000	
<b>118.7</b>	12.6	13490	17.8	8.4	14578	12.9	4.2	16591	7.3	20000	
<b>142.5</b>	10.5	13971	15.4	7.0	15088	11.1	3.5	17155	6.3	20000	
<b>173.8</b>	8.6	13123	11.9	5.8	14178	8.5	2.9	16133	4.9	20000	

Tutti i rapporti evidenziati (es. 45.16) hanno dimensioni particolari della coppia conica in certe versioni; vedere tavole dimensionali.

All ratios grey highlighted (ex. 45.16) have specific dimensions of the bevel gear set in some versions; see dimensional tables.

Alle mit (es. 45.16) gekennzeichneten Übersetzungen haben in bestimmten Versionen besondere Dimensionen des Kegelradtriebs. Siehe auch Dimensionstabellen.

Les rapports repérés par (es. 45.16) ont des dimensions de couple conique particulières. Voir les tableaux dimensionnels.

Todas las relaciones indicadas con (es. 45.16) tienen dimensiones particulares del par cónico según las versiones; ver las tablas de dimensión.

As relações marcadas com (es. 45.16) têm dimensões particulares da engrenagem cônica em certas versões; vide tabelas dimensionais.



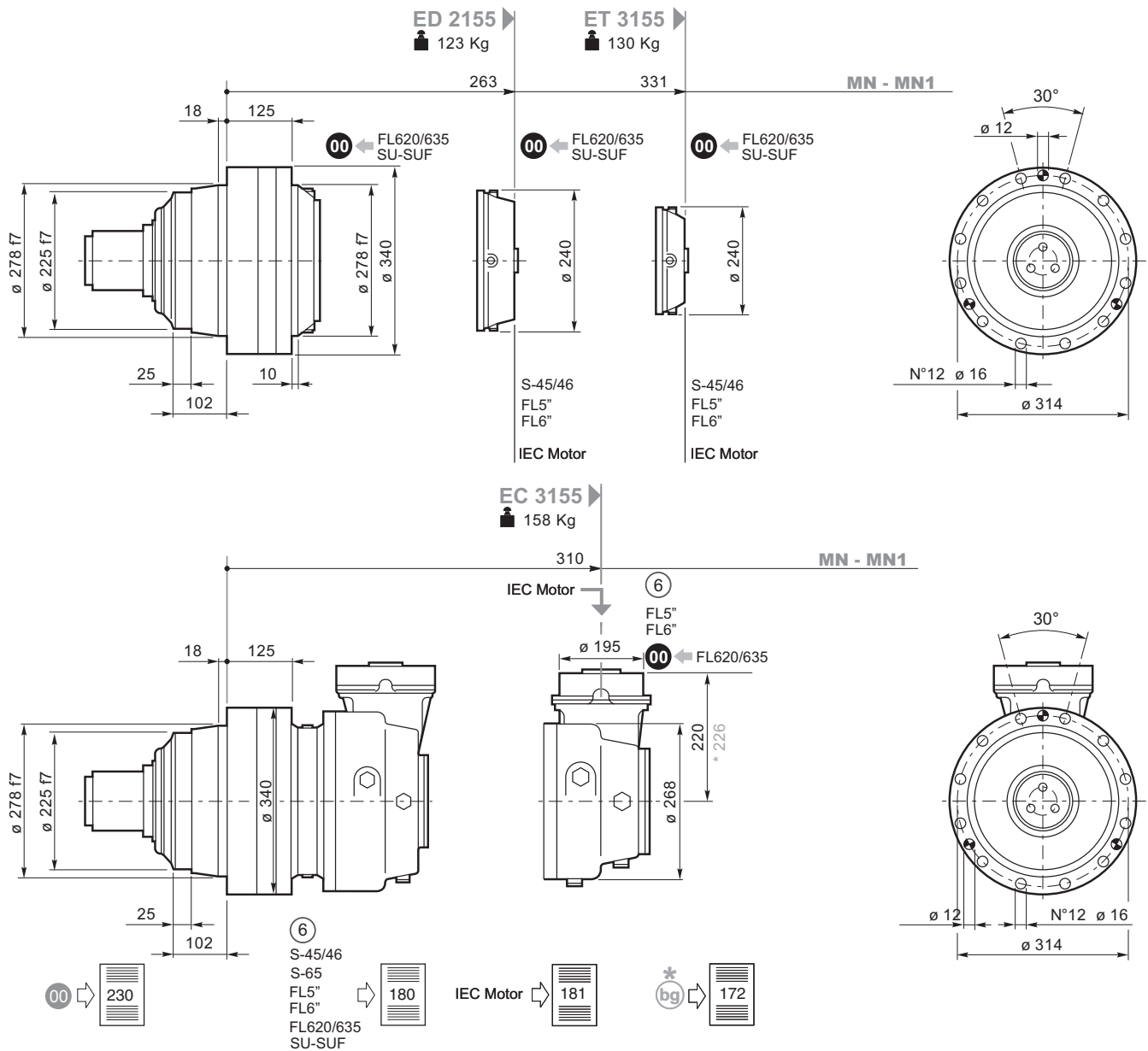
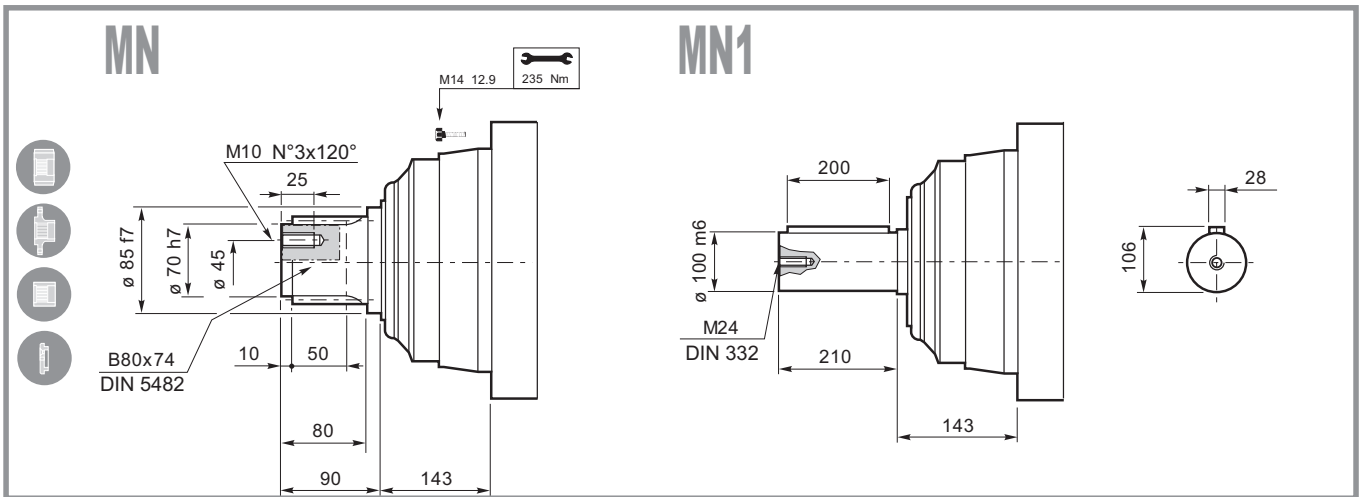

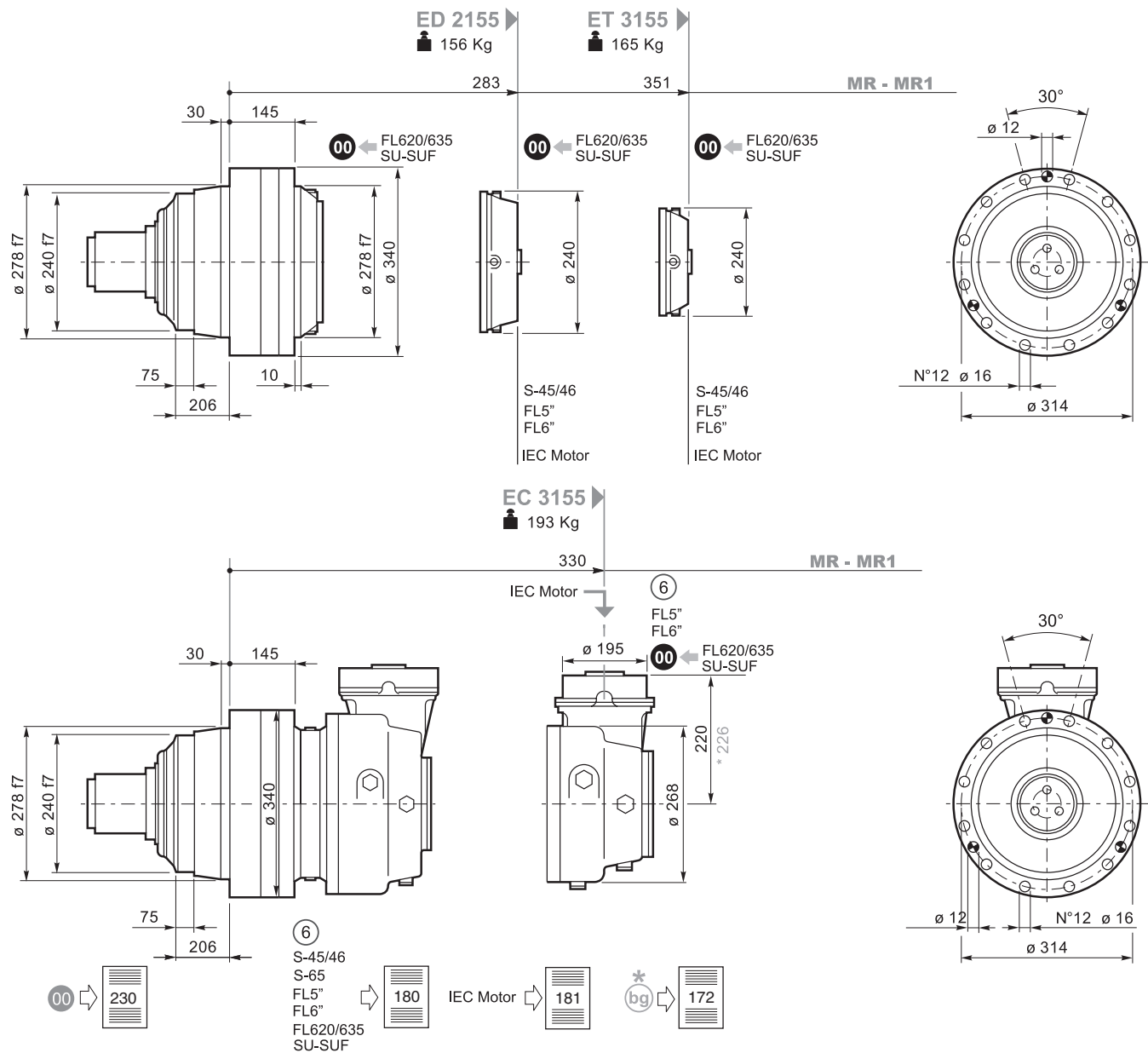
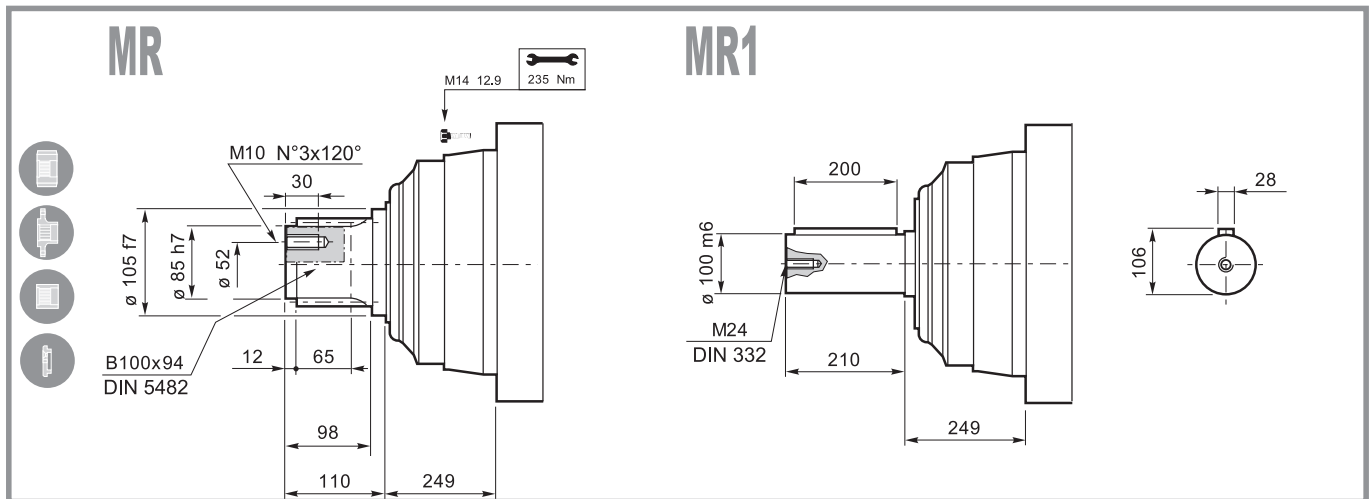

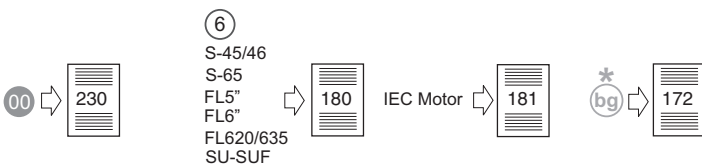
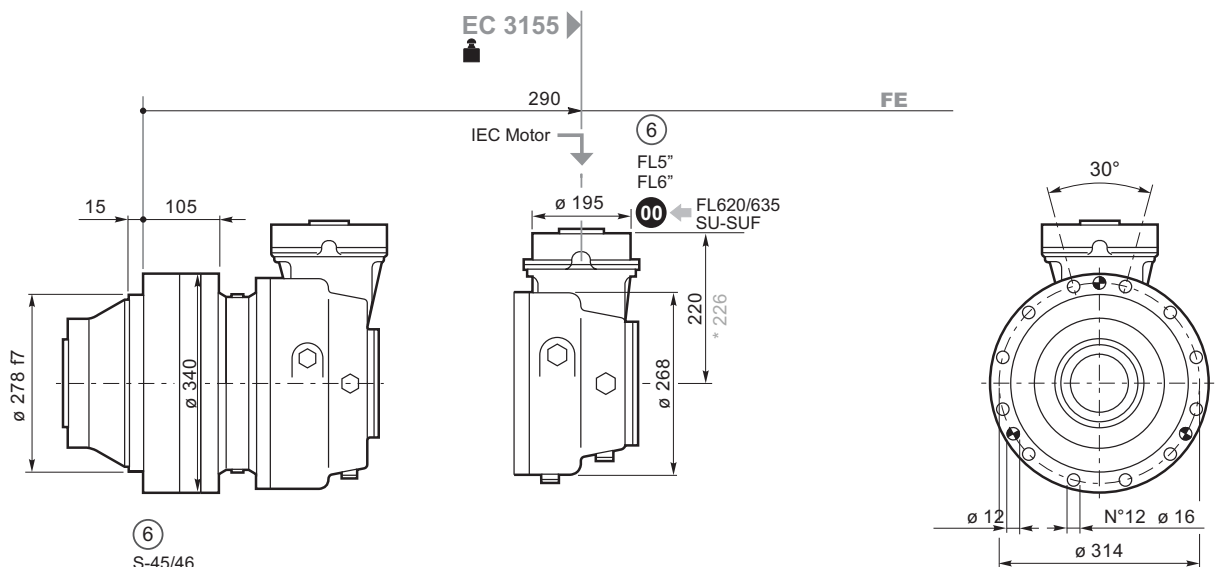
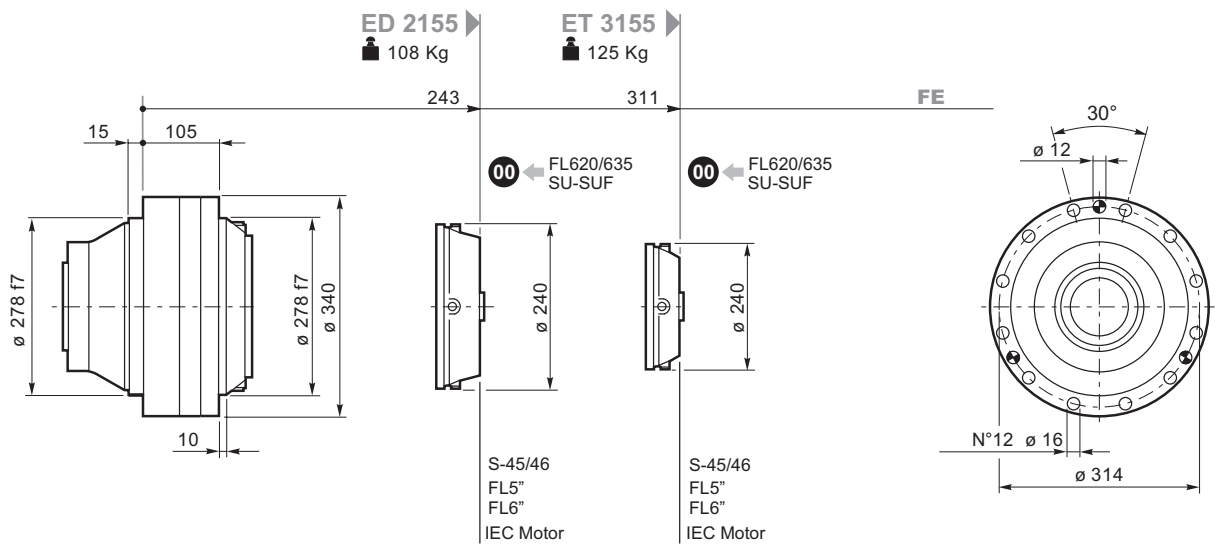
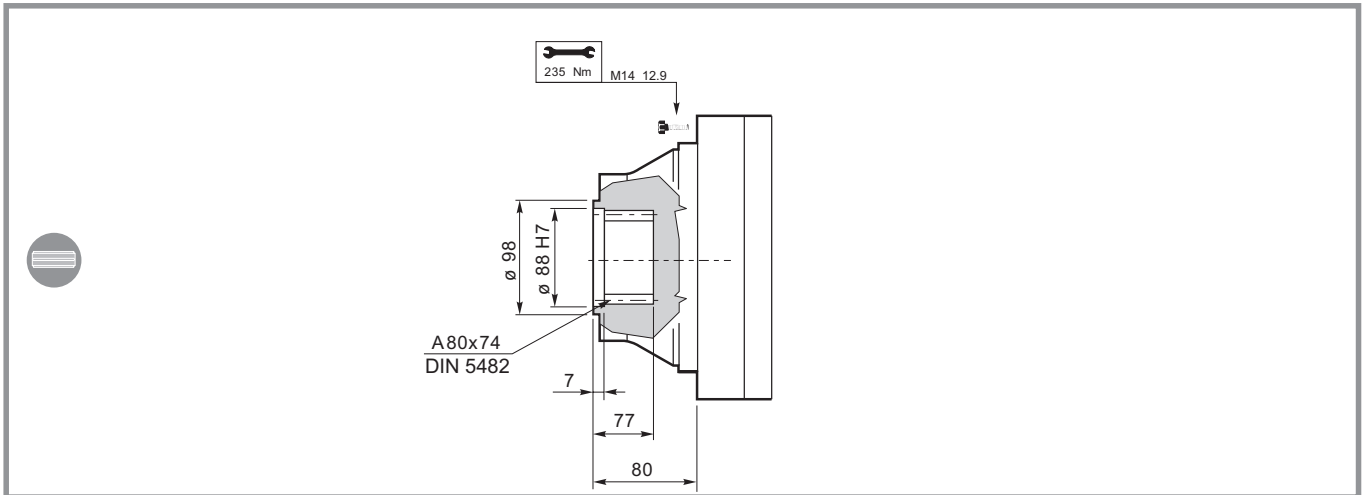





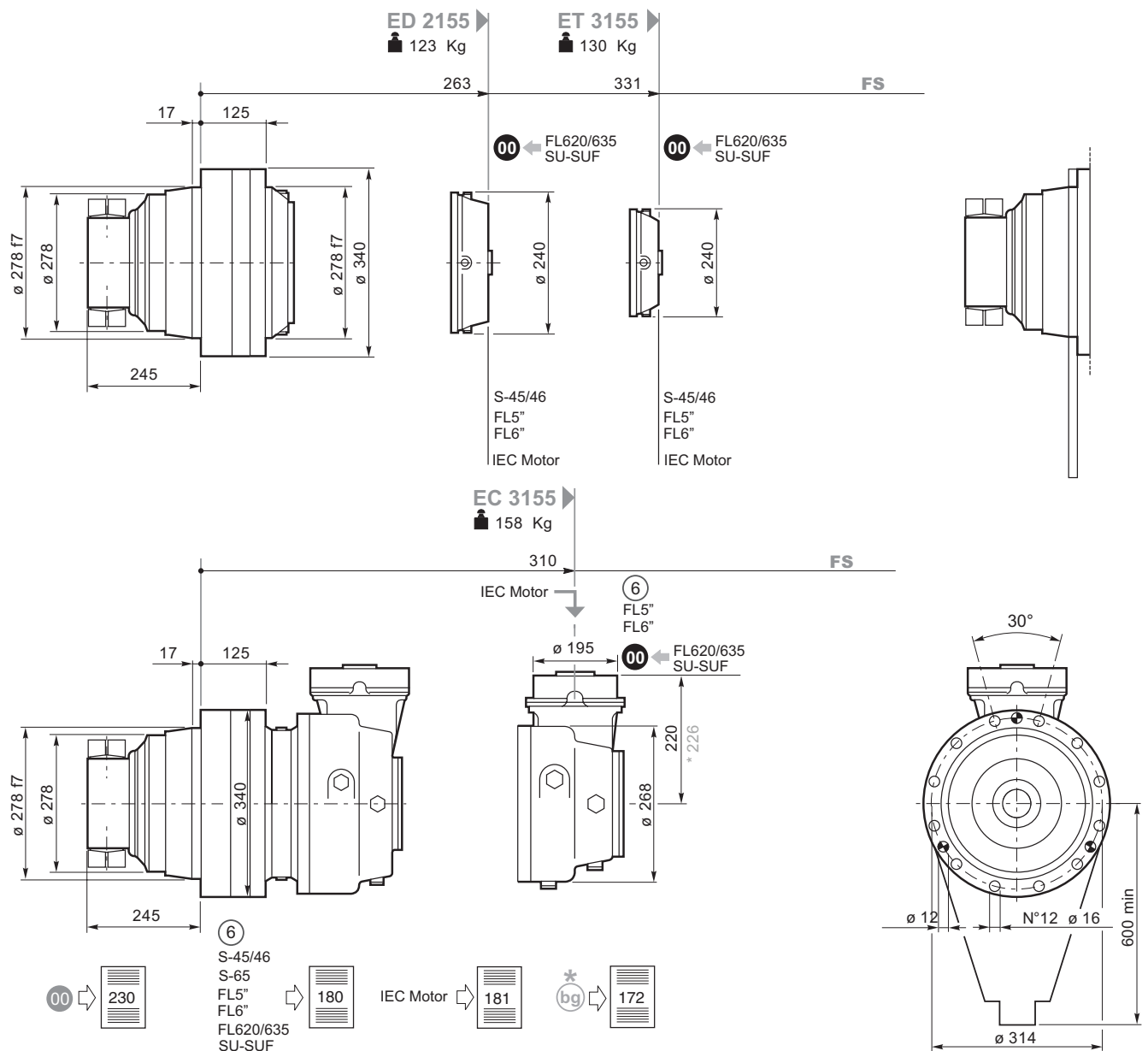
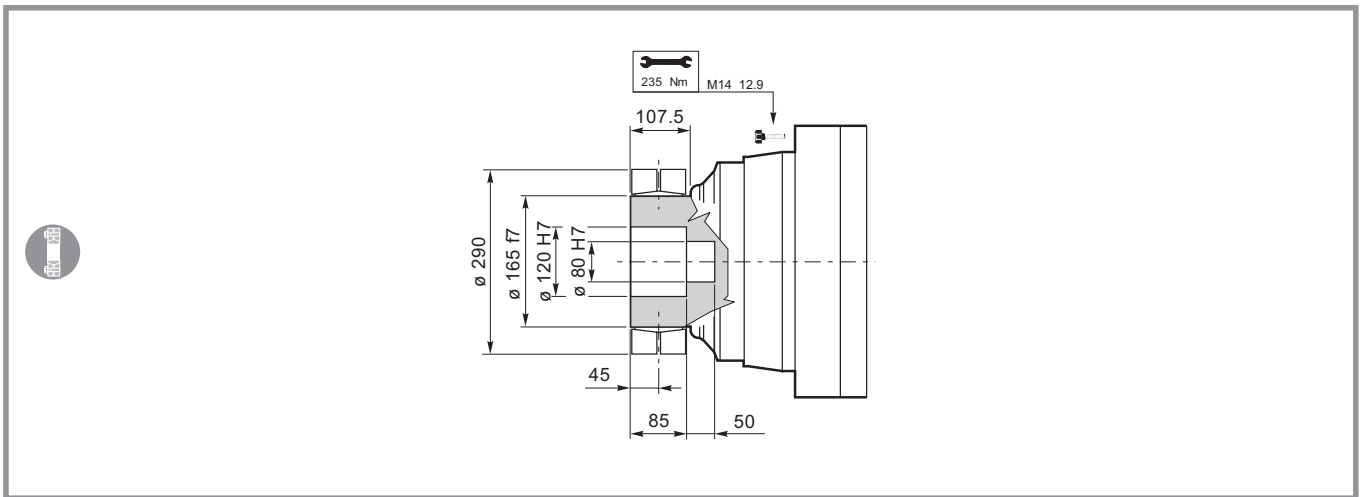

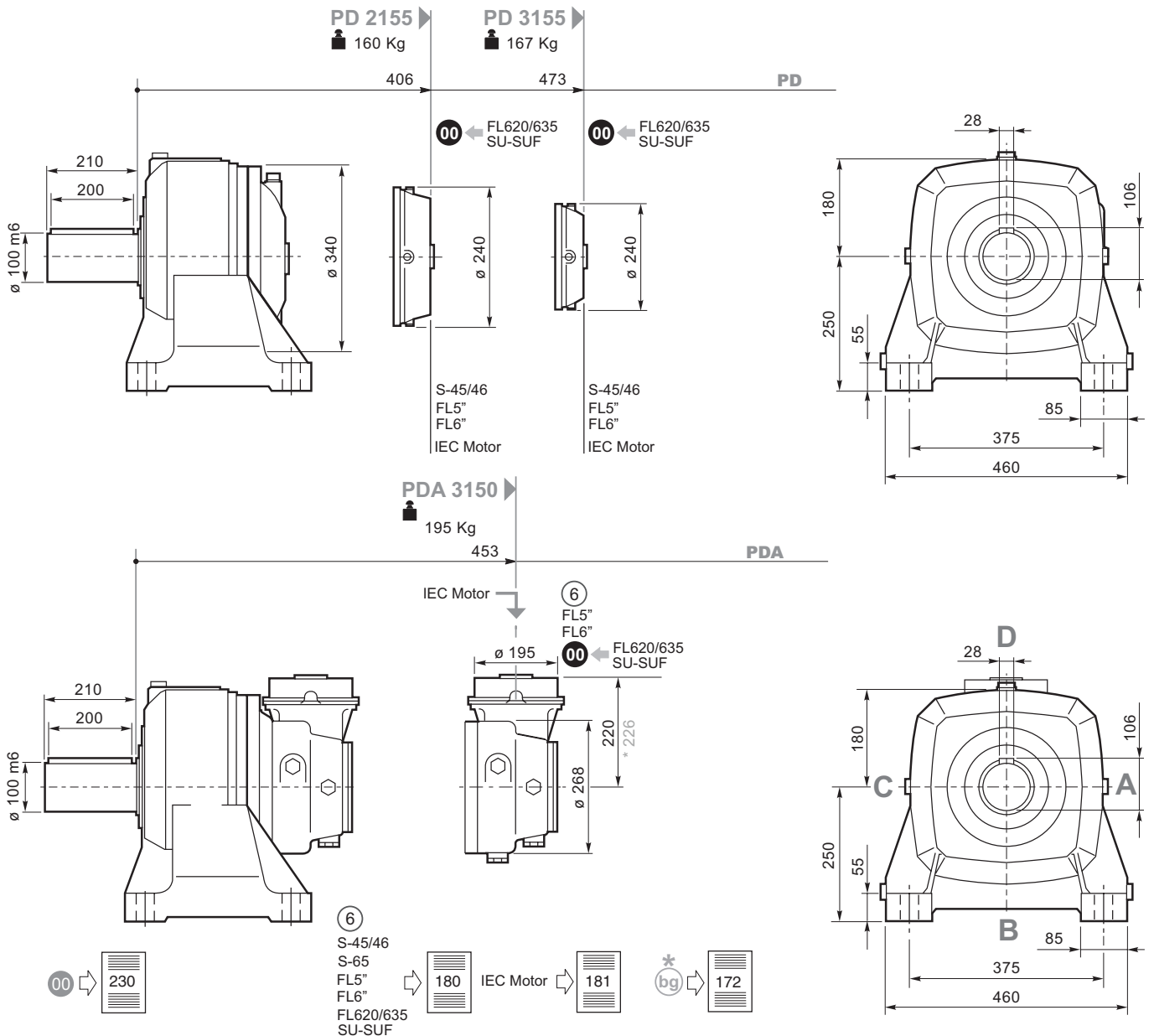
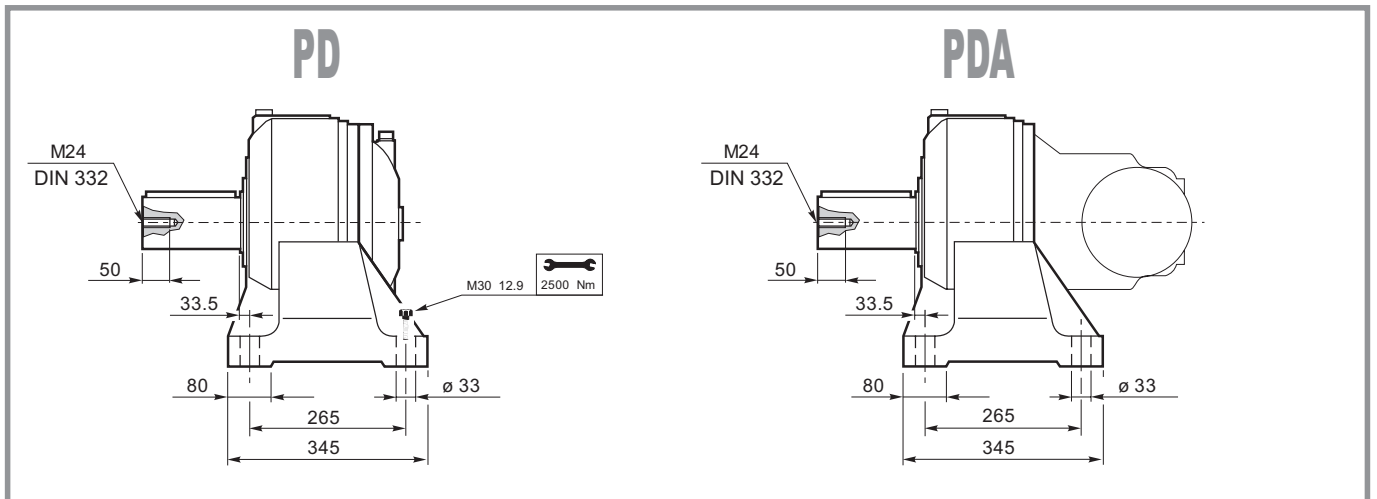

## S45CR1-S46C1

## S65CR1

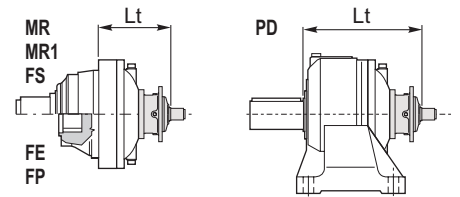
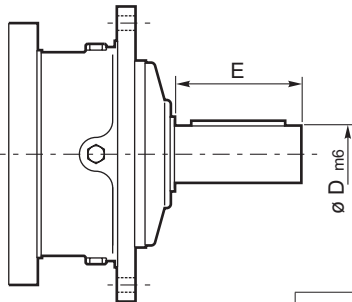

	D m6	E		Lt				
				MN-MN1-FS	MR-MR1	FE	FP	PD
<b>S45 CR1</b>	65	105	<b>ED 2155</b>	399.5	419.5	379.5		542.5
			<b>ET 3155</b>	407.5	427.5		550.5	
<b>S46 C1</b>	65	105	<b>ED 2155</b>	440.5	460.5	420.5		583.5
			<b>ET 3155</b>	448.5	468.5		591.5	
<b>S65 CR1</b>	80	130	<b>ED 2155</b>	439	459	419		582

## SU2

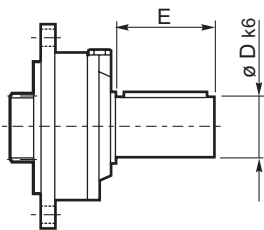

	D k6	E		Lt				
				MN MN1 FS	MR MR1	FE	FP	PD
<b>SU 2</b>	40	58	<b>ED 2155</b>	323	343	303	335	446
			<b>ET 3155</b>	391	411	371	403	533

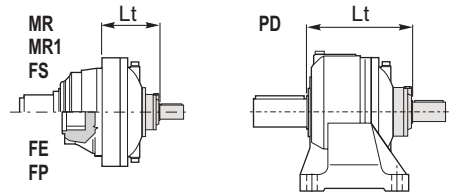

## ⑥ 48.82

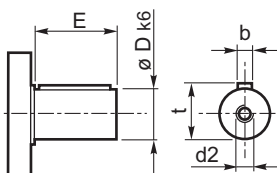

	D	E		Lt						
				MN-MN1-MR-MR1-FS-FE-FP-PDA						
<b>48.82</b>	48	82	<b>EC 3155</b>	280						

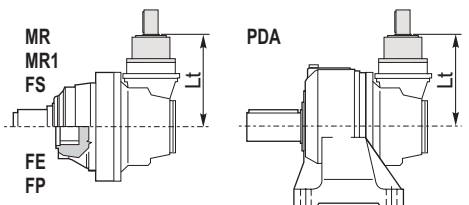

## FL250-FL350-FL450 FL750 FL760-FL960

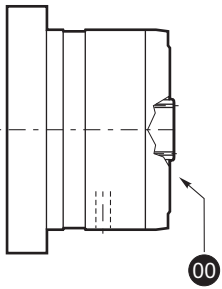

		Lt				
		MN-MN1 FS	MR-MR1	FE	FP	PD- PDA
FL250-FL350 FL450	ED 2155	377	397	357	389	520
	ET 3155	438	458	418	450	581
	EC 3155*	377.5	377.5	377.5	377.5	377.5
	EC 3155	280	280	280	280	280
FL750	ED 2155	390.5	410.5	370.5	402.5	533.5
	ET 3155	451.5	471.5	431.5	436.5	594.5
	EC 3155*	391	391	391	391	391
	EC 3155	293.5	293.5	293.5	293.5	293.5
FL760-FL960	ED 2155	404.5	424.5	384.5	416.5	547.5

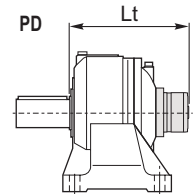
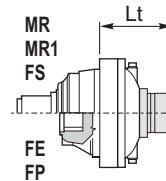

## FL620U-FL635U

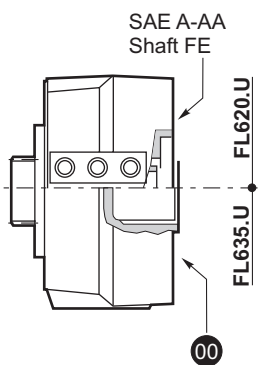

		Lt				
		MN-MN1 FS	MR-MR1	FE	FP	PD
FL620/U	ED 2155	376	396	356	323.5	519
	ET 3155	449	469	429	396.5	592
	EC 3155	324.5	324.5	324.5	324.5	324.5
	EC 3155*	330.5	330.5	330.5	330.5	330.5
FL635U	ED 2155	344.5	382.5	342.5	310	505.5
	ET 3155	435.5	455.5	415.5	383	578.5
	EC 3155	311	311	311	311	311
	EC 3155*	317	317	317	317	317

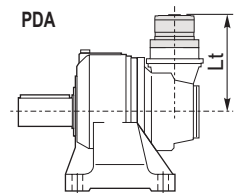
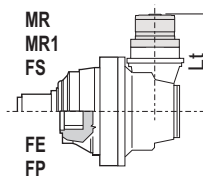

## IEC Motor

		Lt							
		IEC 63	IEC 71	IEC 80 90	IEC 100 112	IEC 132	IEC 160 180	IEC 200	IEC 225
ED 2155	MN-MN1-FS			299	300	367	320	408	438
ED 2155	MR-MR1			319	320	387	340	428	458
ED 2155	FE			279	280	347	300	388	418
ED 2155	FP			311.5	312.5	379.5	332.5	420.5	450.5
ET 3155	MN-MN1-FS	365	367	372	373	440	471	481	511
ET 3155	MR-MR1	365	367	372	393	460	491	501	531
ET 3155	FE	365	367	372	353	420	451	461	491
ET 3155	FP	397.5	399.5	404.5	385.5	452.5	483.5	493.5	523.5
PD 2155	PD			442	443	510	463	551	588
PD 3155	PD	508	510	515	516	583	614	624	654
EC 3155	MN-MR-MN1-MR1	240	242	247	248	315	346		
EC 3155*	FE-FS-FP-PDA	246	248	253	254	321	352		

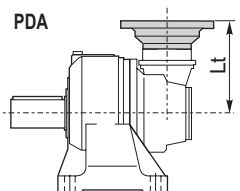
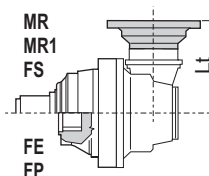
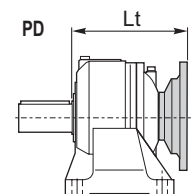
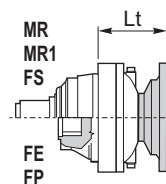



**Flangia ruota**  
Driving flange  
Radnabenflansch  
Flasque de roue  
Brida de la rueda  
Flange de roda

**FA 150**

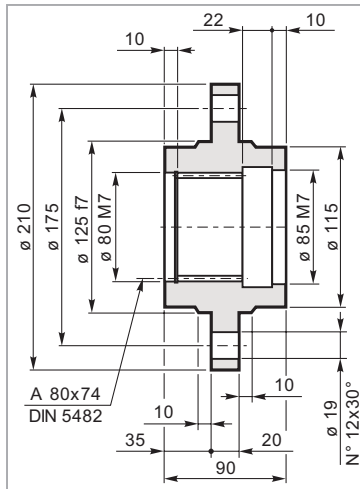

Mat. C40 UNI EN 10083  
Code: 34701521800



**Manicotto scanalato**  
Splined bush  
Keilmuffe  
Manchon cannelée  
Manguito acanalado  
Luva ranhurada

**FR 150**

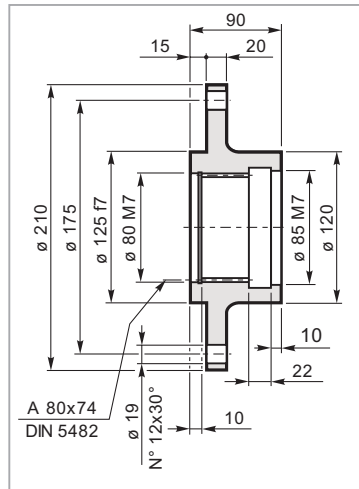

Mat. C40 UNI EN 10083  
Code: 34701421800



**Pignoni**  
Pinion  
Ritzel  
Pignon  
Piñones  
Pinhões

**IR 150**

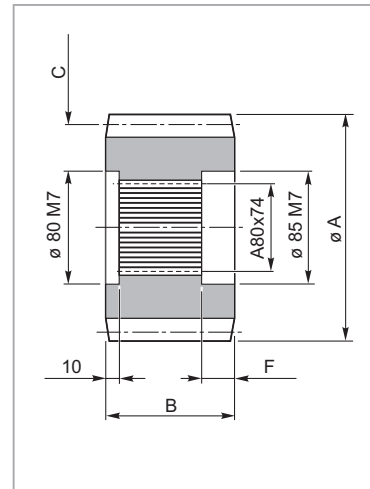

code	A	B	C	F
335.3543.0600	159	90	M=10 Z=13 X=0.5	31



**Rondella di fermo**  
Shaft cover  
Gegenscheibe  
Rondelle frein  
Arandela de bloqueo  
Amuela de encosto

**MS 150**

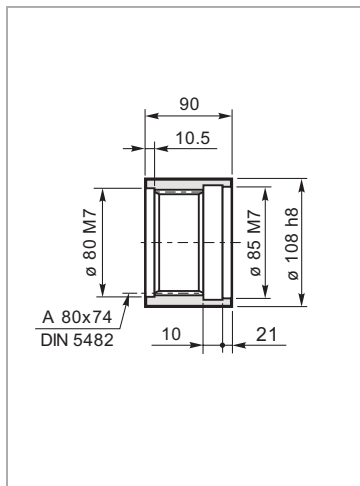

Mat. 39NiCrMo3 UNI EN 10083  
Code: 39103040600



**RDF 150**

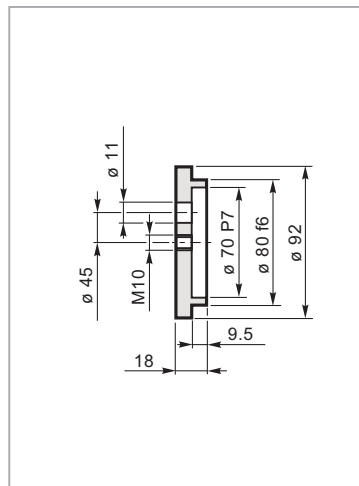

Mat. C40 UNI EN 10083  
Code: 37200940800



**Barra scanalata**  
Splined bar  
Zugspindel  
Barre cannelée  
Barra acanalada  
Barra ranhurada

**BS 150**

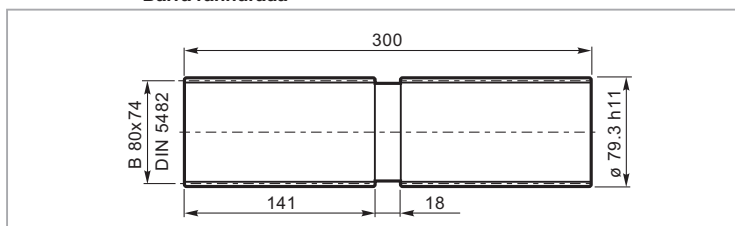

Mat. 39NiCrMo3 UNI EN 10083  
Code: 39127230100

Carichi radiali sugli alberi uscita / Radial loads on output shafts  
 Radiallasten auf de Abtriebswellen / Charges radiales sur les arbres de sortie  
 Cargas sobre los ejes de salida / Cargas radiais nos eixos de saida

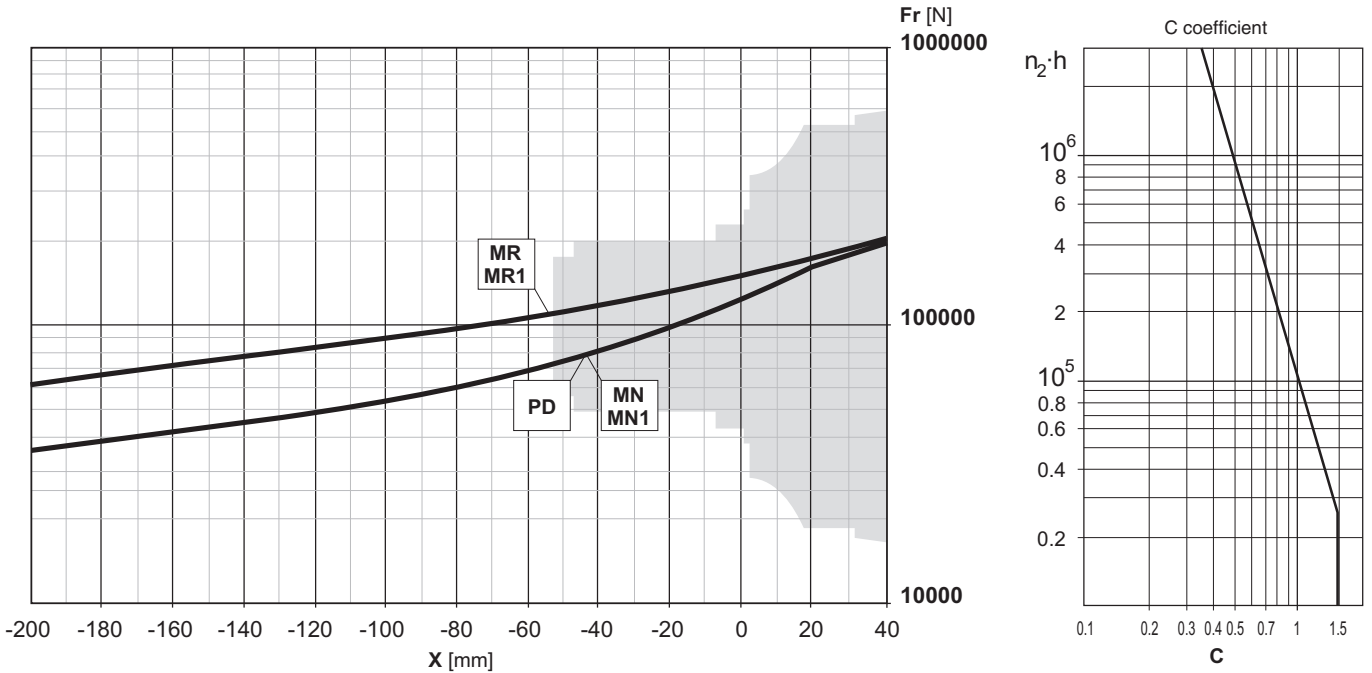

Carichi assiali / Axial loads / Axialkräfte / Charges axiales / Cargas axiales / Forças axiais

	Flange mounted		PD-PDA
	MN-MN1	MR-MR1	MR1
$F_{a\text{din}}$ [N]	68000	100000	40000
$F_{a\text{max}}$ [N]	680000	100000	40000

Carichi radiali sugli alberi entrata / Radial loads on input shafts  
 Radiallasten auf de Antriebswellen / Charges radiales sur les arbres d'entrée  
 Cargas sobre los ejes de entrada / Cargas radiais nos eixos de entrada

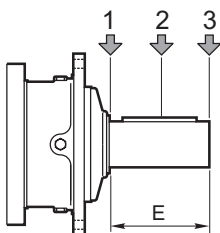

Type	E	$Fr$ [N]					
		$n_1 \cdot h = 10^7$			$n_1 \cdot h = 10^8$		
		1	2	3	1	2	3
S45 CR1	105	10000	6000	4000	5000	3000	2000
S46 C1	105	14000	8800	6400	7000	4400	3200
S65 CR1	130	23800	15500	9600	11900	7800	4800

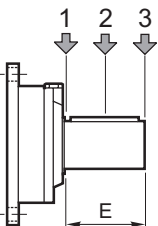

Type	E	$Fr$ [N]					
		$n_1 \cdot h = 10^7$			$n_1 \cdot h = 10^8$		
		1	2	3	1	2	3
SU2	58	3000	2000	1500	1400	1000	700

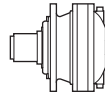

$i_{eff}$	1500			1000			500			$T_{2max}$ [Nm]	$P_T$ [kW]
	$n_2$ [rpm]	$T_2$ [Nm]	$P_2$ [kW]	$n_2$ [rpm]	$T_2$ [Nm]	$P_2$ [kW]	$n_2$ [rpm]	$T_2$ [Nm]	$P_2$ [kW]		
<b>EM 1250</b>											
4.04	371	6707	261	248	7574	196	124	9325	121	35000	50
5.12	293	6948	213	195	7847	161	98	9661	99	35000	
6.00	250	7194	188	167	8124	142	83	10002	87	35000	
<b>ED 2250</b>											
14.14	106	9056	101	71	10227	76	35.4	12591	46.6	35000	30
15.59	96	9320	94	64	10526	71	32.1	12959	43.5	35000	
17.49	86	9480	85	57	10706	64	28.6	13181	39.5	35000	
20.20	74	9701	75	49.5	10956	57	24.8	13489	35.0	35000	
22.17	68	10786	76	45.1	12181	58	22.6	14996	35.4	35000	
25.60	59	11261	69	39.1	12718	52	19.5	15658	32.0	35000	
30.72	48.8	11894	61	32.6	13433	45.8	16.3	16538	28.2	35000	
36.00	41.7	12314	54	27.8	13711	39.9	13.9	14586	21.2	35000	
<b>ET 3250</b>											
43.55	34.4	12565	45.3	23.0	14190	34.1	11.5	17471	21.0	35000	20
49.49	30.3	13187	41.9	20.2	14893	31.5	10.1	18335	19.4	35000	
58.40	25.7	13858	37.3	17.1	15651	28.1	8.6	19269	17.3	35000	
61.23	24.5	13805	35.4	16.3	15590	26.7	8.2	19194	16.4	35000	
70.70	21.2	14127	31.4	14.1	15955	23.6	7.1	19642	14.5	35000	
83.43	18.0	14846	28.0	12.0	16767	21.0	6.0	20642	13.0	35000	
90.44	16.6	15518	27.0	11.1	17526	20.3	5.5	21577	12.5	35000	
104.4	14.4	15881	23.9	9.6	17935	18.0	4.8	21831	10.9	35000	
114.6	13.1	17656	24.2	8.7	18932	17.3	4.4	21050	9.6	35000	
121.2	12.4	16607	21.5	8.3	18755	16.2	4.1	22136	9.6	35000	
146.5	10.2	17451	18.7	6.8	18668	13.3	3.4	20506	7.3	35000	
158.8	9.4	18809	18.6	6.3	19598	12.9	3.1	21928	7.2	35000	
184.3	8.1	19040	16.2	5.4	20178	11.5	2.7	22242	6.3	35000	
216.0	6.9	15468	11.2	4.6	16343	7.9	2.3	18719	4.5	35000	
261.0	5.7	15713	9.5	3.8	16968	6.8	1.9	19411	3.9	35000	
<b>EQ 4250</b>											
282.7	5.3	22231	12.4	3.5	24311	9.0	1.8	27017	5.0	35000	15
310.4	4.8	21812	11.0	3.2	22644	7.6	1.6	24291	4.1	35000	
350.4	4.3	23452	10.5	2.9	25059	7.5	1.4	26805	4.0	35000	
405.3	3.7	22633	8.8	2.5	23809	6.2	1.2	26733	3.5	35000	
438.6	3.4	19760	7.1	2.3	20624	4.9	1.1	22075	2.6	35000	
490.7	3.1	22752	7.3	2.0	23596	5.0	1.0	26762	2.9	35000	
579.0	2.6	23095	6.3	1.7	23945	4.3	0.86	27696	2.5	35000	
627.7	2.4	24833	6.2	1.6	25894	4.3	0.80	27687	2.3	35000	
724.8	2.1	23564	5.1	1.4	25109	3.6	0.69	29001	2.1	35000	
795.4	1.9	24677	4.9	1.3	26600	3.5	0.63	30169	2.0	35000	
878.7	1.7	22200	4.0	1.1	23169	2.8	0.57	24830	1.5	35000	
1016	1.5	22549	3.5	0.98	23517	2.4	0.49	25182	1.3	35000	
1102	1.4	21717	3.1	0.91	22433	2.1	0.45	23587	1.1	35000	
1273	1.2	25078	3.1	0.79	25905	2.1	0.39	27237	1.1	35000	
1336	1.1	24140	2.8	0.75	26267	2.1	0.37	30411	1.2	35000	
1546	0.97	24819	2.5	0.65	27102	1.8	0.32	31337	1.1	35000	
1845	0.81	21425	1.8	0.54	23340	1.3	0.27	26895	0.76	35000	
1935	0.78	26068	2.1	0.52	28428	1.5	0.26	32808	0.89	35000	
2268	0.66	23687	1.6	0.44	25505	1.2	0.22	28884	0.67	35000	
2339	0.64	27152	1.8	0.43	29579	1.3	0.21	34085	0.76	35000	
2741	0.55	24522	1.4	0.36	26393	1.0	0.18	29869	0.57	35000	

**1500**  
HOURS LIFE

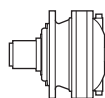

**250**

$i_{eff}$	1500			1000			500			$T_{2max}$ [Nm]	$P_T$ [kW]
	$n_2$ [rpm]	$T_2$ [Nm]	$P_2$ [kW]	$n_2$ [rpm]	$T_2$ [Nm]	$P_2$ [kW]	$n_2$ [rpm]	$T_2$ [Nm]	$P_2$ [kW]		
<b>EM 1250</b>											
4.04	371	11849	461	248	13382	347	124	16475	214	35000	50
5.12	293	12276	377	195	13864	284	98	17069	175	35000	
6.00	250	12501	327	167	13288	232	83	14437	126	35000	
<b>ED 2250</b>											
14.14	106	15999	178	71	18069	134	35.4	22246	82	35000	30
15.59	96	16467	166	64	18597	125	32.1	22773	76	35000	
17.49	86	16748	150	57	18915	113	28.6	23092	69	35000	
20.20	74	17140	133	49.5	19357	100	24.8	21970	57	35000	
22.17	68	18421	131	45.1	19142	90	22.6	22007	52	35000	
25.60	59	18680	115	39.1	19714	81	19.5	22633	46.3	35000	
30.72	48.8	19003	97	32.6	20353	69	16.3	22135	37.7	35000	
36.00	41.7	15462	67	27.8	16593	48.3	13.9	19053	27.7	35000	
<b>ET 3250</b>											
43.55	34.4	22200	80	23.0	24311	58	11.5	27713	33.3	35000	20
49.49	30.3	23028	73	20.2	24916	53	10.1	28375	30.0	35000	
58.40	25.7	21911	59	17.1	23733	42.6	8.6	26263	23.5	35000	
61.23	24.5	23497	60	16.3	24527	42.0	8.2	27974	23.9	35000	
70.70	21.2	22341	49.6	14.1	23292	34.5	7.1	26426	19.6	35000	
83.43	18.0	22733	42.8	12.0	23673	29.7	6.0	27372	17.2	35000	
90.44	16.6	22818	39.6	11.1	24509	28.4	5.5	26937	15.6	35000	
104.4	14.4	23256	35.0	9.6	24745	24.8	4.8	28688	14.4	35000	
114.6	13.1	24437	33.5	8.7	26366	24.1	4.4	29932	13.7	35000	
121.2	12.4	23600	30.6	8.3	25563	22.1	4.1	28712	12.4	35000	
146.5	10.2	21383	22.9	6.8	22704	16.2	3.4	24723	8.8	35000	
158.8	9.4	23440	23.2	6.3	24839	16.4	3.1	28906	9.5	35000	
184.3	8.1	23790	20.3	5.4	25682	14.6	2.7	29830	8.5	35000	
216.0	6.9	21752	15.8	4.6	23458	11.4	2.3	26621	6.5	35000	
261.0	5.7	22536	13.6	3.8	24290	9.7	1.9	27543	5.5	35000	
<b>EQ 4250</b>											
282.7	5.3	30294	16.8	3.5	31911	11.8	1.8	37097	6.9	35000	15
310.4	4.8	28632	14.5	3.2	31109	10.5	1.6	35687	6.0	35000	
350.4	4.3	28403	12.7	2.9	31014	9.3	1.4	35877	5.4	35000	
405.3	3.7	27816	10.8	2.5	29953	7.7	1.2	33155	4.3	35000	
438.6	3.4	23496	8.4	2.3	25477	6.1	1.1	29551	3.5	35000	
490.7	3.1	31440	10.1	2.0	34082	7.3	1.0	38975	4.2	35000	
579.0	2.6	32500	8.8	1.7	35206	6.4	0.86	40219	3.6	35000	
627.7	2.4	29731	7.4	1.6	32542	5.4	0.80	37675	3.1	35000	
724.8	2.1	33979	7.4	1.4	36774	5.3	0.69	41957	3.0	35000	
795.4	1.9	34762	6.9	1.3	37323	4.9	0.63	42078	2.8	35000	
878.7	1.7	26605	4.8	1.1	28634	3.4	0.57	33356	2.0	35000	
1016	1.5	26993	4.2	0.98	29590	3.0	0.49	34405	1.8	35000	
1102	1.4	24398	3.5	0.91	25202	2.4	0.45	26498	1.3	35000	
1273	1.2	28173	3.5	0.79	29102	2.4	0.39	30599	1.3	35000	
1336	1.1	35726	4.2	0.75	38701	3.0	0.37	44220	1.7	35000	
1546	0.97	36773	3.7	0.65	39813	2.7	0.32	45454	1.5	35000	
1845	0.81	31467	2.7	0.54	34018	1.9	0.27	38754	1.1	35000	
1935	0.78	38436	3.1	0.52	41579	2.3	0.26	46534	1.3	35000	
2268	0.66	33238	2.3	0.44	35661	1.6	0.22	40162	0.93	35000	
2339	0.64	39879	2.7	0.43	43112	1.9	0.21	49114	1.1	35000	
2741	0.55	34351	2.0	0.36	36844	1.4	0.18	41475	0.79	35000	



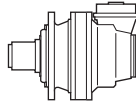

$i_{eff}$	1500			1000			500			$T_{2max}$ [Nm]	$P_T$ [kW]
	$n_2$ [rpm]	$T_2$ [Nm]	$P_2$ [kW]	$n_2$ [rpm]	$T_2$ [Nm]	$P_2$ [kW]	$n_2$ [rpm]	$T_2$ [Nm]	$P_2$ [kW]		
<b>EC 2250</b>											
11.11	135	4329	61	90	4889	46.1	45.0	6019	28.4	35000	18
14.08	107	5486	61	71	6196	46.1	35.5	7628	28.4	35000	
16.50	91	6429	61	61	7261	46.1	30.3	8939	28.4	35000	
17.92	84	4025	35.3	56	4546	26.6	27.9	5597	16.4	26476	
21.00	71	4717	35.3	47.6	5327	26.6	23.8	6559	16.4	31027	
24.93	60	4026	25.4	40.1	4547	19.1	20.1	5598	11.8	21639	
29.22	51	4718	25.4	34.2	5329	19.1	17.1	6561	11.8	25359	
<b>EC 3250</b>											
46.78	32.1	10551	35.4	21.4	11915	26.7	10.7	14670	16.4	35000	14
52.48	28.6	11835	35.4	19.1	13366	26.7	9.5	16456	16.4	35000	
53.76	27.9	12124	35.4	18.6	13692	26.7	9.3	16858	16.4	35000	
60.60	24.8	13489	35.0	16.5	15233	26.3	8.3	18755	16.2	35000	
72.05	20.8	7051	15.4	13.9	7963	11.6	6.9	9804	7.1	35000	
80.82	18.6	7910	15.4	12.4	8933	11.6	6.2	10998	7.1	35000	
93.32	16.1	9134	15.4	10.7	10315	11.6	5.4	12699	7.1	35000	
102.4	14.6	10024	15.4	9.8	11321	11.6	4.9	13938	7.1	35000	
112.0	13.4	10960	15.4	8.9	12378	11.6	4.5	15239	7.1	35000	
118.3	12.7	11575	15.4	8.5	13073	11.6	4.2	16094	7.1	35000	
141.9	10.6	13890	15.4	7.0	15687	11.6	3.5	19313	7.1	35000	
166.3	9.0	15133	14.3	6.0	15655	9.9	3.0	17795	5.6	35000	
<b>EC 4250</b>											
212.1	7.1	19642	14.5	4.7	21862	10.8	2.4	23291	5.8	35000	10
228.6	6.6	20871	14.3	4.4	23357	10.7	2.2	26584	6.1	35000	
252.2	5.9	21481	13.4	4.0	23793	9.9	2.0	26371	5.5	35000	
282.9	5.3	21848	12.1	3.5	24014	8.9	1.8	26041	4.8	35000	
314.9	4.8	20767	10.4	3.2	21786	7.2	1.6	23449	3.9	35000	
363.6	4.1	22136	9.6	2.8	22971	6.6	1.4	25126	3.6	35000	
392.0	3.8	17662	7.1	2.6	18453	4.9	1.3	19778	2.6	35000	
432.3	3.5	19478	7.1	2.3	20351	4.9	1.2	21813	2.6	35000	
484.9	3.1	21850	7.1	2.1	22829	4.9	1.0	24468	2.6	35000	
559.9	2.7	23025	6.5	1.8	23874	4.5	0.89	27506	2.6	35000	
614.5	2.4	23513	6.0	1.6	25363	4.3	0.81	28797	2.5	35000	
709.6	2.1	24157	5.3	1.4	26047	3.8	0.70	29556	2.2	35000	
811.9	1.8	18598	3.6	1.2	19578	2.5	0.62	22723	1.5	35000	
857.5	1.7	25025	4.6	1.2	26969	3.3	0.58	30579	1.9	35000	
1029	1.5	23570	3.6	0.97	24811	2.5	0.49	28798	1.5	35000	
1206	1.2	21065	2.7	0.83	22719	2.0	0.41	25791	1.1	35000	

Tutti i rapporti evidenziati (es. 11.11) hanno dimensioni particolari della coppia conica in certe versioni; vedere tavole dimensionali.

All ratios grey highlighted (ex. 11.11) have specific dimensions of the bevel gear set in some versions; see dimensional tables.

Alle mit (es. 11.11) gekennzeichneten Übersetzungen haben in bestimmten Versionen besondere Dimensionen des Kegelradtriebs. Siehe auch Dimensionstabellen.

Les rapports repérés par (es. 11.11) ont des dimensions de couple conique particulières. Voir les tableaux dimensionnels.

Todas las relaciones indicadas con (es. 11.11) tienen dimensiones particulares del par cónico según las versiones; ver las tablas de dimensión.

As relações marcadas com (es. 11.11) têm dimensões particulares da engrenagem cônica em certas versões; vide tabelas dimensionais.



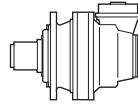

$i_{eff}$	1500			1000			500			$T_{2max}$ [Nm]	$P_T$ [kW]	
	$n_2$ [rpm]	$T_2$ [Nm]	$P_2$ [kW]	$n_2$ [rpm]	$T_2$ [Nm]	$P_2$ [kW]	$n_2$ [rpm]	$T_2$ [Nm]	$P_2$ [kW]			
<b>EC 2250</b>												
11.11	135	7648	108	90	8638	81	45.0	10634	50	35000	18	
14.08	107	9693	108	71	10947	81	35.5	13477	50	35000		
16.50	91	11359	108	61	12828	81	30.3	15794	50	35000		
17.92	84	7112	62	56	8032	46.9	27.9	9888	28.9	26476		
21.00	71	8334	62	47.6	9412	46.9	23.8	11588	28.9	31027		
24.93	60	7114	44.8	40.1	8034	33.7	20.1	9346	19.6	21639		
29.22	51	8336	44.8	34.2	9415	33.7	17.1	10952	19.6	25359		
<b>EC 3250</b>												
46.78	32.1	18641	63	21.4	21052	47.1	10.7	25918	29.0	35000	14	
52.48	28.6	20910	63	19.1	23615	47.1	9.5	27062	27.0	35000		
53.76	27.9	21102	62	18.6	22848	44.5	9.3	26054	25.4	35000		
60.60	24.8	21970	57	16.5	22934	39.6	8.3	25563	22.1	35000		
72.05	20.8	12458	27.2	13.9	14069	20.5	6.9	17321	12.6	35000		
80.82	18.6	13974	27.2	12.4	15782	20.5	6.2	19430	12.6	35000		
93.32	16.1	16137	27.2	10.7	18224	20.5	5.4	22437	12.6	35000		
102.4	14.6	17710	27.2	9.8	20001	20.5	4.9	24624	12.6	35000		
112.0	13.4	18285	25.6	8.9	19104	17.9	4.5	22267	10.4	35000		
118.3	12.7	20451	27.2	8.5	23096	20.5	4.2	28435	12.6	35000		
141.9	10.6	23174	25.6	7.0	24212	17.9	3.5	28220	10.4	35000		
166.3	9.0	20703	19.6	6.0	22347	14.1	3.0	25390	8.0	35000		
<b>EC 4250</b>												
212.1	7.1	26426	19.6	4.7	28779	14.2	2.4	33116	8.2	35000		10
228.6	6.6	30478	20.9	4.4	32553	14.9	2.2	37316	8.5	35000		
252.2	5.9	30989	19.3	4.0	33600	14.0	2.0	37959	7.9	35000		
282.9	5.3	30622	17.0	3.5	33249	12.3	1.8	38099	7.1	35000		
314.9	4.8	24864	12.4	3.2	25989	8.6	1.6	28885	4.8	35000		
363.6	4.1	28712	12.4	2.8	30011	8.6	1.4	33355	4.8	35000		
392.0	3.8	21065	8.4	2.6	22019	5.9	1.3	25639	3.4	35000		
432.3	3.5	23232	8.4	2.3	24284	5.9	1.2	28276	3.4	35000		
484.9	3.1	26061	8.4	2.1	27240	5.9	1.0	31719	3.4	35000		
559.9	2.7	30094	8.4	1.8	31456	5.9	0.89	36627	3.4	35000		
614.5	2.4	33028	8.4	1.6	34523	5.9	0.81	40198	3.4	35000		
709.6	2.1	34069	7.5	1.4	36586	5.4	0.70	41260	3.0	35000		
811.9	1.8	26750	5.2	1.2	29008	3.7	0.62	33197	2.1	35000		
857.5	1.7	32828	6.0	1.2	34204	4.2	0.58	39951	2.4	35000		
1029	1.5	33901	5.2	0.97	36763	3.7	0.49	42071	2.1	35000		
1206	1.2	29746	3.9	0.83	31949	2.8	0.41	36041	1.6	35000		

Tutti i rapporti evidenziati (es. 11.11) hanno dimensioni particolari della coppia conica in certe versioni; vedere tavole dimensionali.

All ratios grey highlighted (ex. 11.11) have specific dimensions of the bevel gear set in some versions; see dimensional tables.

Alle mit (es. 11.11) gekennzeichneten Übersetzungen haben in bestimmten Versionen besondere Dimensionen des Kegelradtriebs. Siehe auch Dimensionstabellen.

Les rapports repérés par (es. 11.11) ont des dimensions de couple conique particulières. Voir les tableaux dimensionnels.

Todas las relaciones indicadas con (es. 11.11) tienen dimensiones particulares del par cónico según las versiones; ver las tablas de dimensión.

As relações marcadas com (es. 11.11) têm dimensões particulares da engrenagem cônica em certas versões; vide tabelas dimensionais.



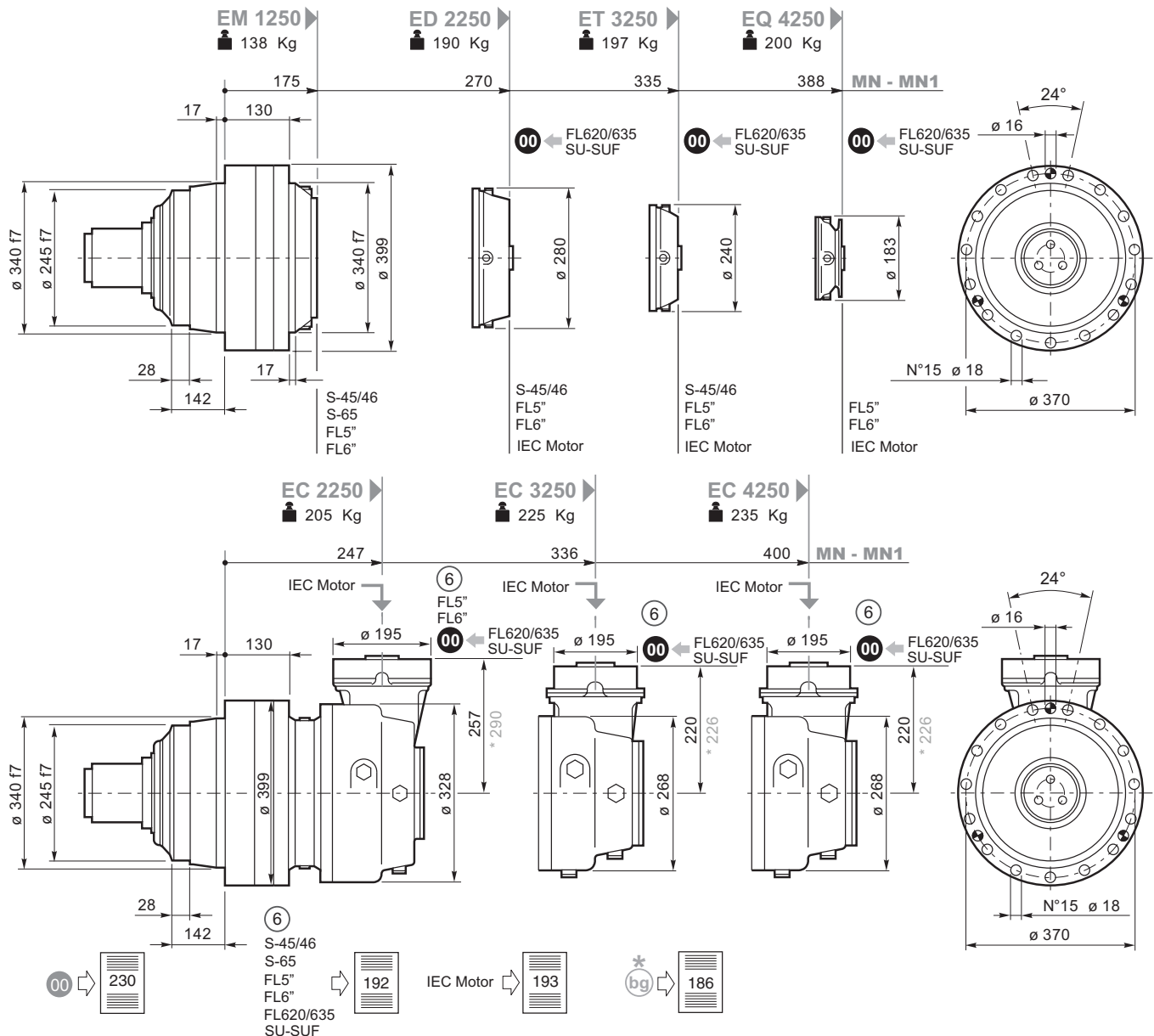
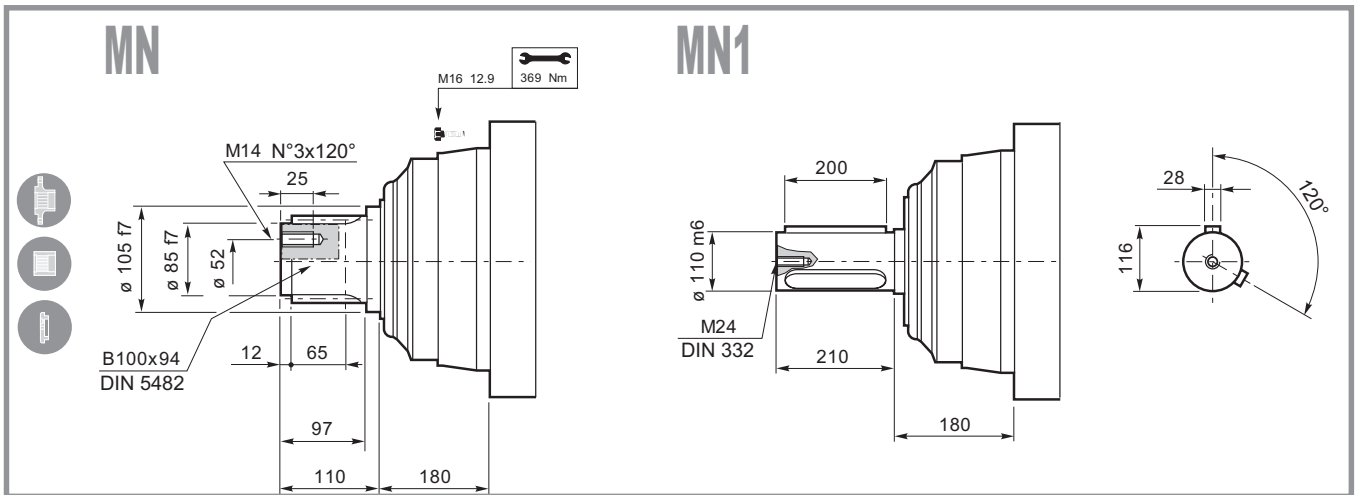

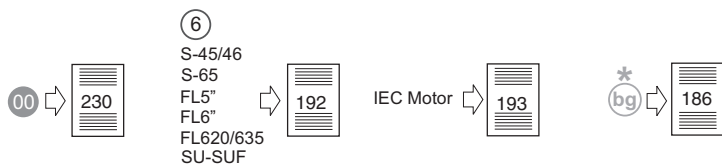
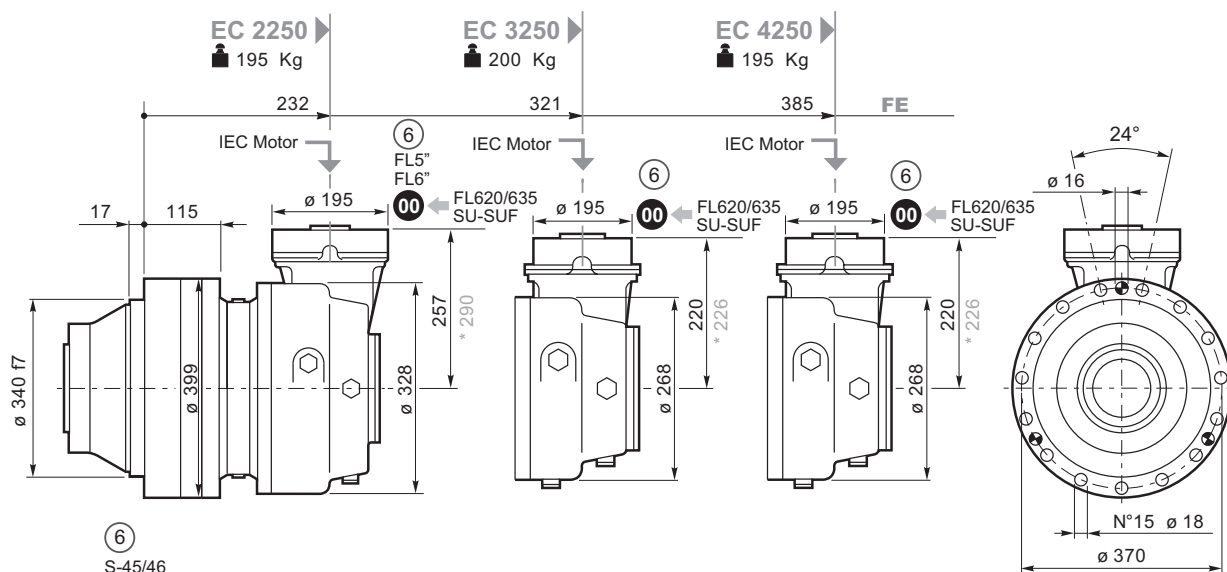
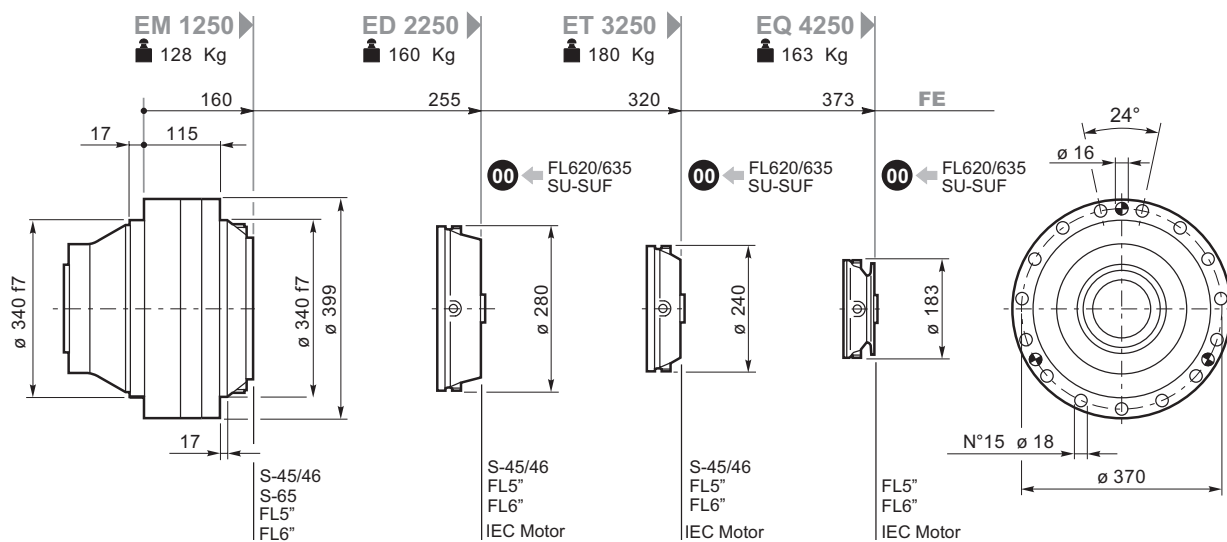
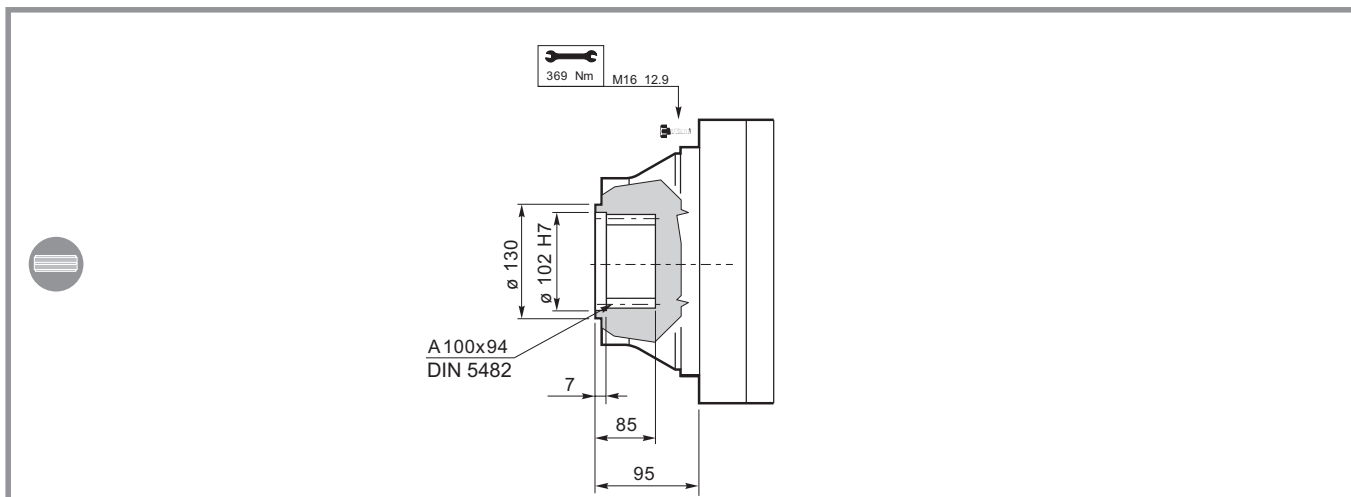

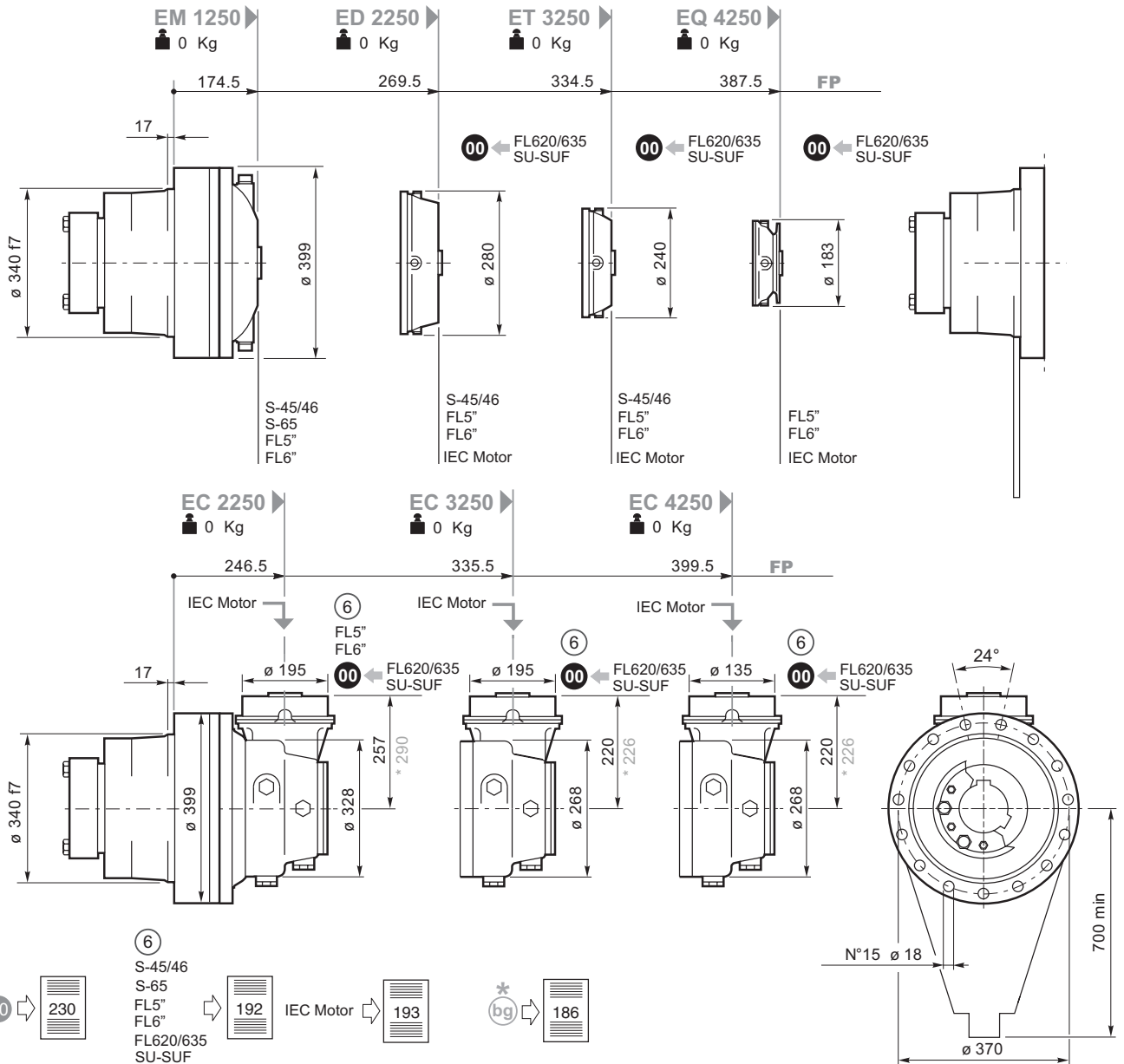
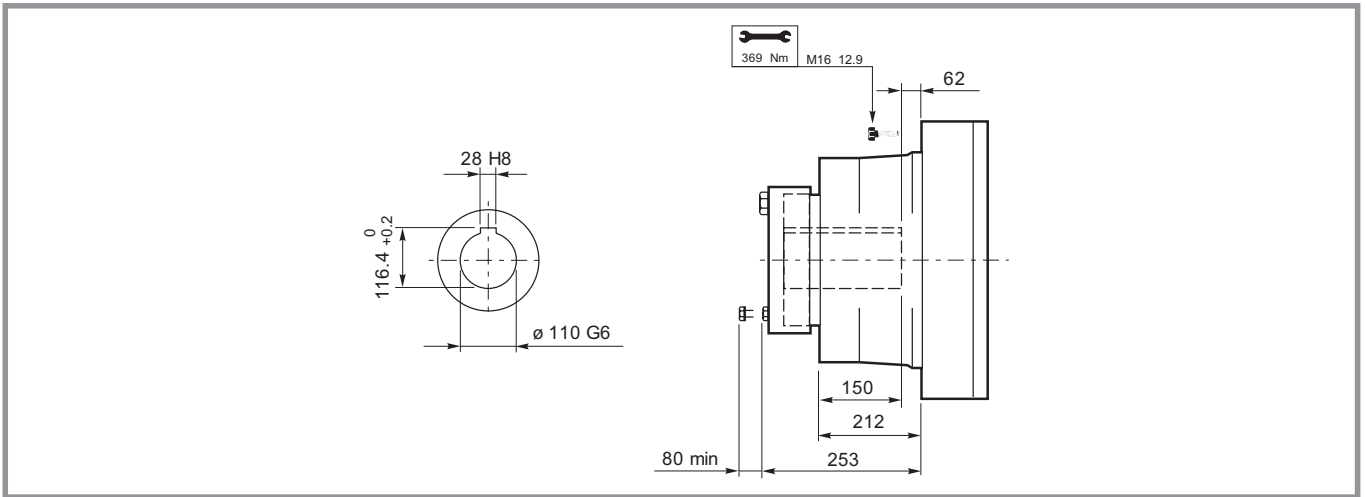

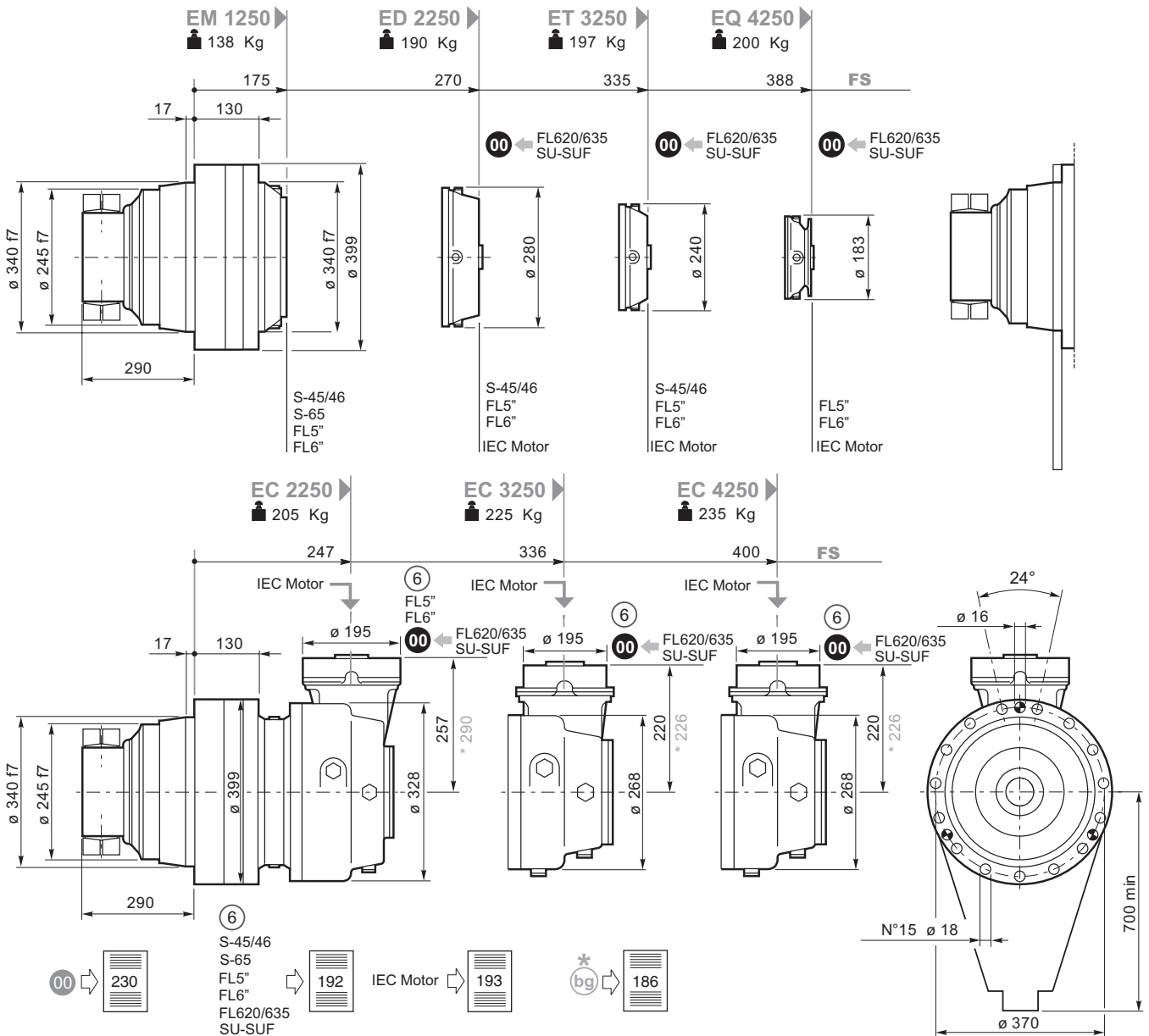
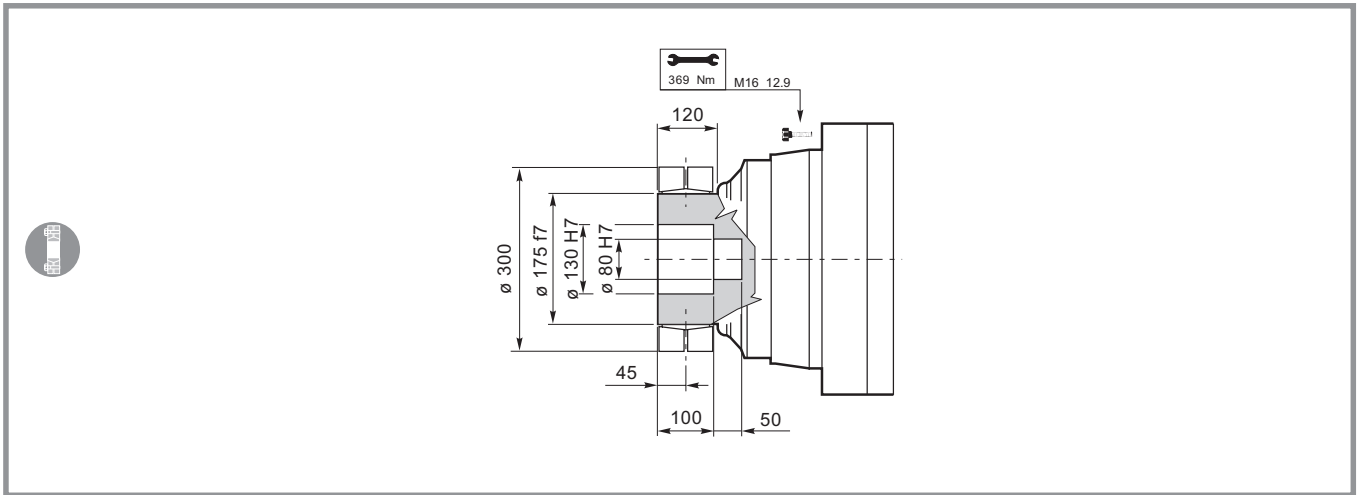

## S45CR1-S46C1

## S65CR1

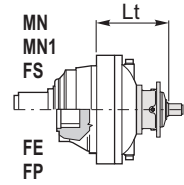
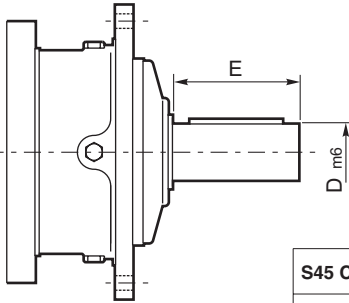

	D m6	E		Lt		
				MN-MN1-FS	FE	FP
<b>S45 CR1</b>	65	105	<b>ED 2250</b>	398	383	397.5
			<b>ET 3250</b>	398	383	397.5
<b>S46 C1</b>	65	105	<b>ED 2250</b>	439	424	438.5
			<b>ET 3250</b>	439	424	438.5
<b>S65 CR1</b>	80	130	<b>EM 1250</b>	403	388	402.5
			<b>ED 2250</b>	437	422	436.5

## SU2

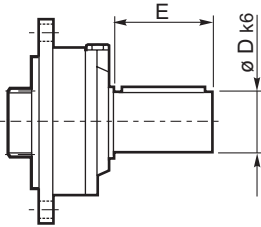

	D k6	E		Lt		
				MN-MN1-FS	FE	FP
<b>SU 2</b>	40	58	<b>ET 3250</b>	395	380	394.5
			<b>EQ 4250</b>	448	433	447.5

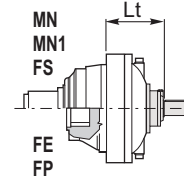

## ⑥ 48.82

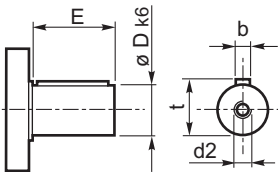

	D	E		Lt	
				MN-MN1-FS-FE-FP	
<b>48.82</b>	48	82	<b>EC 2250</b>	317	
			<b>EC 3250</b>	280	
			<b>EC 4250</b>	280	

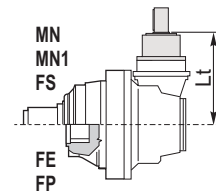

## FL250-FL350-FL450 FL750 FL760-FL960

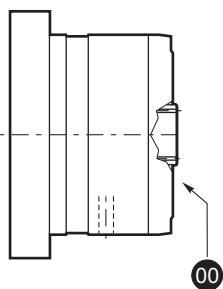

**FL620/10**  
**FL635/10**

**FL620U-FL635U**

SAE A-AA  
Shaft FE

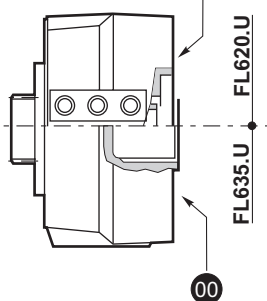

		Lt		
		MN-MN1-FS	FE	FP
FL250-FL350 FL450	ED 2250	429	414	—
	ET 3250	429	414	428.5
	EC 2250*	441	441	441
	EC 2250	408	408	408
	EC 3250*	377	377	377
	EC 3250	280	280	280
	EC 4250*	377	377	377
FL750	ED 2250	442	427	—
	ET 3250	442	427	441.5
	EC 2250*	455	455	455
	EC 2250	422	422	422
FL760-FL960	EM 1250	308	293	307.5

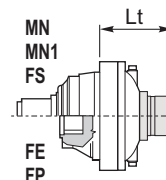

		Lt		
		MN-MN1-FS	FE	FP
FL620/U	EM 1250	279.5	264.5	279
	ED 2250	374.5	359.5	374
	ET 3250	439.5	424.5	439
	EQ 4250	492.5	477.5	492
	EC 2250	361.5	361.5	361.5
	EC 2250*	394.5	394.5	394.5
	EC 3250	324.5	324.5	324.5
	EC 3250*	330.5	330.5	330.5
	EC 4250	324.5	324.5	324.5
	EC 4250*	330.5	330.5	330.5
	FL635U	EM 1250	266	251
ED 2250		361	346	360.5
ET 3250		426	411	425.5
EQ 4250		479	464	478.5
EC 2250		348	348	348
EC 2250*		381	381	381
EC 3250		311	311	311
EC 3250*		317	317	317
EC 4250		311	311	311
EC 4250*		317	317	317
FL620/10		EQ 4250	452	427
FL635/10	EQ 4250	433	418	433

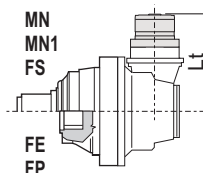

## IEC Motor

		Lt							
		IEC 63	IEC 71	IEC 80 90	IEC 100 112	IEC 132	IEC 160 180	IEC 200	IEC 225
ED 2250	MN-MN1-FS	290	292	297	298	365		406	424
ED 2250	FE	275	277	282	283	350		391	372
ED 2250	FP								
ET 3250	MN-MN1-FS	335	357	362	363	430	461	471	490
ET 3250	FE	340	342	347	348	415	446	456	438
ET 3250	FP								
EQ 4250	MN-MN1-FS	408	410	415	416	483			
EQ 4250	FE	393	395	400	401	468			
EQ 4250	FP								
EC 2250	MN-MN1-FE-FS-FP	277	279	284	285	352	383		
EC 2250*	MN-MN1-FE-FS-FP	310	312	317	318	385	416		
EC 3250	MN-MN1-FE-FS-FP	240	242	247	248	315	346		508
EC 3250*	MN-MN1-FE-FS-FP	246	248	253	254	321	352		530
EC 4250	MN-MN1-FE-FS-FP	240	242	247	248	315	346		
EC 4250*	MN-MN1-FE-FS-FP	246	248	253	254	321	352		

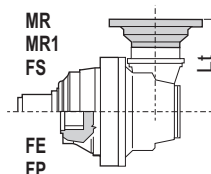
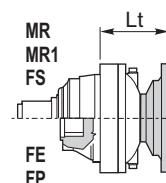





**Flangia ruota**  
**Driving flange**  
**Radnabenflansch**  
**Flasque de roue**  
**Brida de la rueda**  
**Flange de roda**

## FA 250

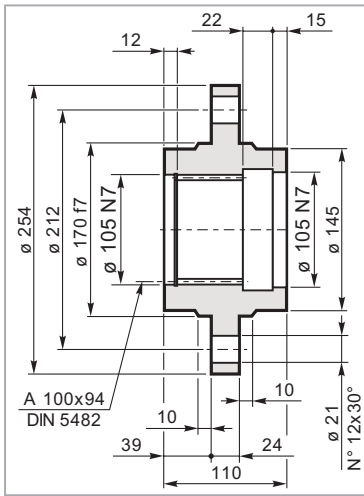

Mat. C40 UNI EN 10083  
 Code: 34702921800



**Flangia ruota**  
**Driving flange**  
**Radnabenflansch**  
**Flasque de roue**  
**Brida de la rueda**  
**Flange de roda**

## FR 250

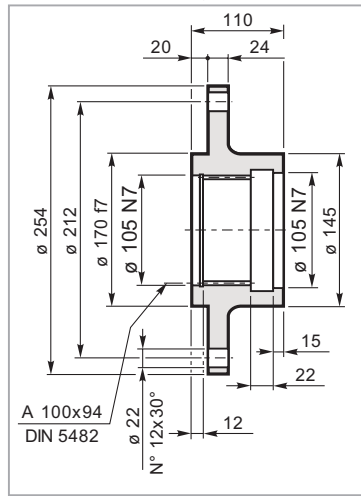

Mat. C40 UNI EN 10083  
 Code: 34703021800



**Manicotto scanalato**  
**Splined bush**  
**Keilmuffe**  
**Manchon cannelée**  
**Manguito acanalado**  
**Luva ranhurada**

## MS 250

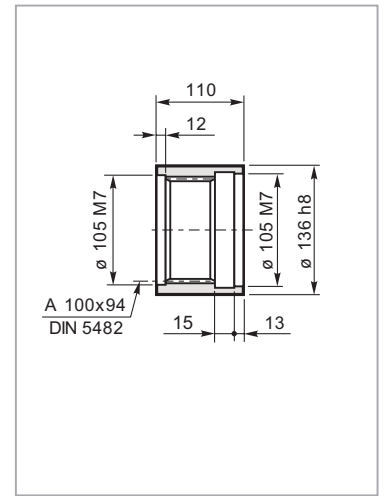

Mat. 39NiCrMo3 UNI EN 10083  
 Code: 39105140600



**Rondella di fermo**  
**Shaft cover**  
**Gegenscheibe**  
**Rondelle frein**  
**Arandela de bloqueo**  
**Amuela de encosto**

## RDF 250

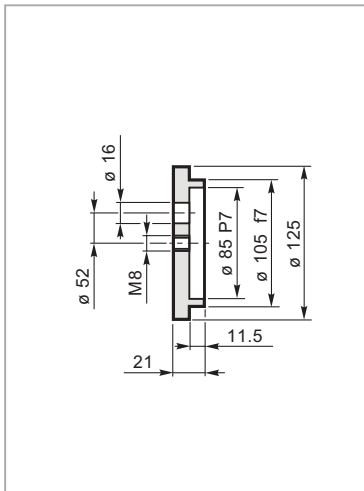

Mat. C40 UNI EN 10083  
 Code: 37201240800



**Barra scanalata**  
**Splined bar**  
**Zugspindel**  
**Barre cannelée**  
**Barra acanalada**  
**Barra ranhurada**

## BS 250

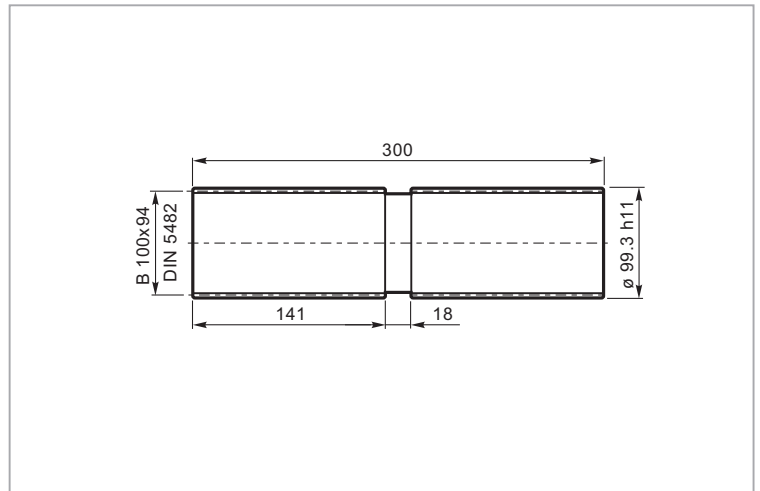

Mat. 39NiCrMo3 UNI EN 10083  
 Code: 39127330100

Carichi radiali sugli alberi uscita / Radial loads on output shafts  
 Radiallasten auf de Abtriebswellen / Charges radiales sur les arbres de sortie  
 Cargas sobre los ejes de salida / Cargas radiais nos eixos de saida

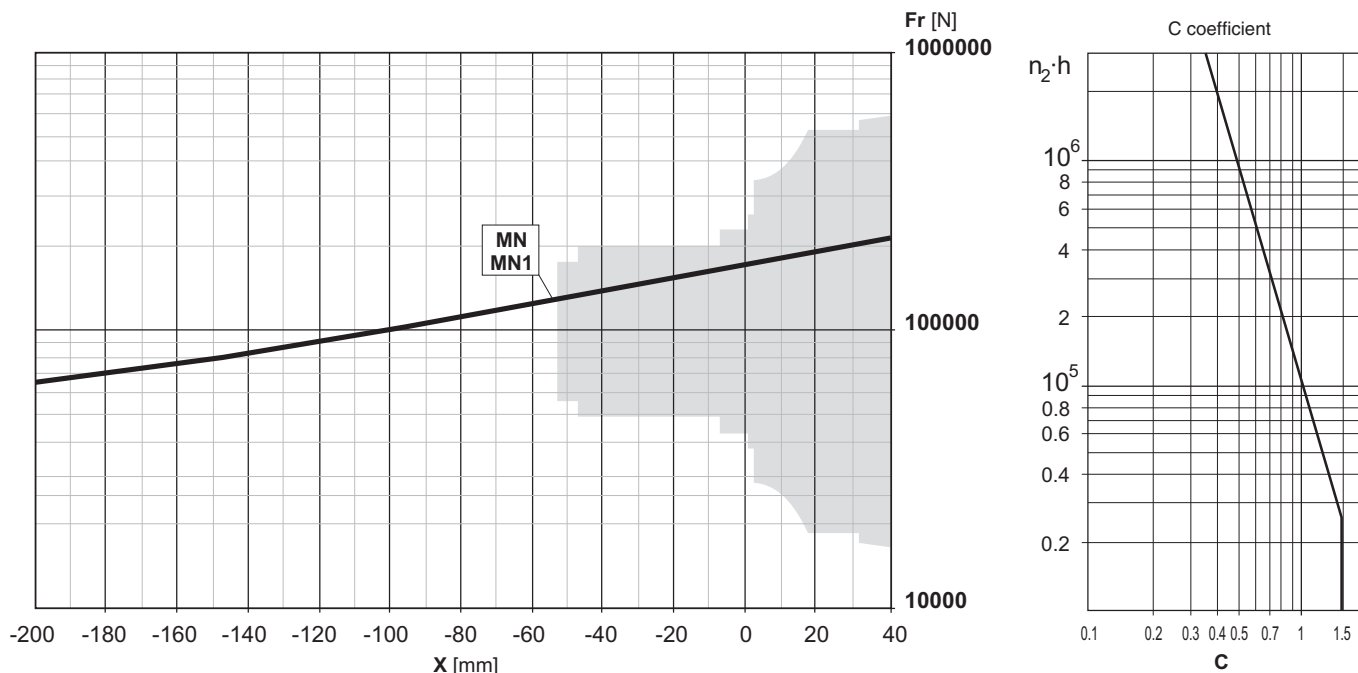

Carichi assiali / Axial loads / Axialkräfte / Charges axiales / Cargas axiales / Forças axiais

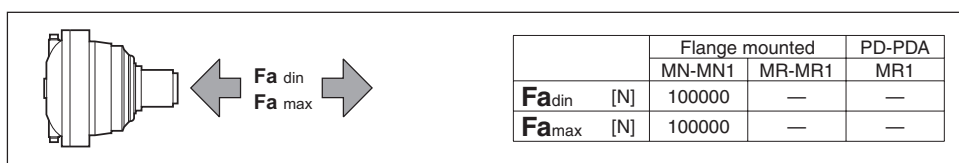

Carichi radiali sugli alberi entrata / Radial loads on input shafts  
 Radiallasten auf de Antriebswellen / Charges radiales sur les arbres d'entrée  
 Cargas sobre los ejes de entrada / Cargas radiais nos eixos de entrada

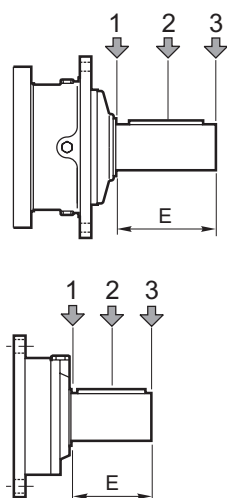

Type	E	$Fr$ [N]					
		$n_1 \cdot h = 10^7$			$n_1 \cdot h = 10^8$		
		1	2	3	1	2	3
<b>S45 CR1</b>	105	10000	6000	4000	5000	3000	2000
<b>S46 C1</b>	105	14000	8800	6400	7000	4400	3200
<b>S65 CR1</b>	130	23800	15500	9600	11900	7800	4800

Type	E	$Fr$ [N]					
		$n_1 \cdot h = 10^7$			$n_1 \cdot h = 10^8$		
		1	2	3	1	2	3
<b>SU2</b>	58	3000	2000	1500	1400	1000	700

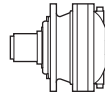

$i_{eff}$	1500			1000			500			$T_{2max}$ [Nm]	$P_T$ [kW]	
	$n_2$ [rpm]	$T_2$ [Nm]	$P_2$ [kW]	$n_2$ [rpm]	$T_2$ [Nm]	$P_2$ [kW]	$n_2$ [rpm]	$T_2$ [Nm]	$P_2$ [kW]			
<b>ED 2255</b>												
16.48	91	10226	97	61	11549	73	30.3	14219	45.2	35000	30	
20.40	74	10902	84	49.0	12312	63	24.5	15158	38.9	35000		
23.47	64	11370	76	42.6	12841	57	21.3	15809	35.3	35000		
25.86	58	11295	69	38.7	12756	52	19.3	15705	31.8	35000		
27.96	54	11983	67	35.8	13533	51	17.9	16661	31.2	35000		
29.75	50	11780	62	33.6	13304	46.8	16.8	16379	28.8	35000		
30.30	49.5	11694	61	33.0	13206	45.6	16.5	14368	24.8	35000		
35.43	42.3	12415	55	28.2	14020	41.4	14.1	17261	25.5	35000		
41.52	36.1	12853	48.6	24.1	13892	35.0	12.0	14766	18.6	35000		
44.54	33.7	13297	46.9	22.5	15017	35.3	11.2	17387	20.4	35000		
52.20	28.7	13668	41.1	19.2	14180	28.4	9.6	15057	15.1	35000		
<b>ET 3255</b>												
57.69	26.0	14892	40.5	17.3	16818	30.5	8.7	20474	18.6	35000	20	
68.08	22.0	15650	36.1	14.7	17674	27.2	7.3	21146	16.3	35000		
71.41	21.0	15876	34.9	14.0	17929	26.3	7.0	21343	15.7	35000		
84.26	17.8	16684	31.1	11.9	18842	23.4	5.9	22036	13.7	35000		
90.50	16.6	16448	28.6	11.1	18566	21.5	5.5	20106	11.6	35000		
105.5	14.2	17847	26.6	9.5	20155	20.0	4.7	23003	11.4	35000		
115.5	13.0	18338	24.9	8.7	19870	18.0	4.3	21283	9.7	35000		
122.4	12.3	18662	23.9	8.2	20712	17.7	4.1	23661	10.1	35000		
144.5	10.4	19496	21.2	6.9	20331	14.7	3.5	21740	7.9	35000		
155.1	9.7	18773	19.0	6.4	19507	13.2	3.2	22308	7.5	35000		
183.2	8.2	19030	16.3	5.5	20153	11.5	2.7	23022	6.6	35000		
202.7	7.4	20193	15.7	4.9	21018	10.9	2.5	22430	5.8	35000		
230.3	6.5	18584	12.7	4.3	19459	8.8	2.2	20954	4.8	35000		
256.9	5.8	19890	12.2	3.9	21516	8.8	1.9	24532	5.0	35000		
267.3	5.6	18906	11.1	3.7	19779	7.8	1.9	21278	4.2	35000		
322.9	4.6	19314	9.4	3.1	20186	6.5	1.5	21692	3.5	35000		
<b>EQ 4255</b>												
346.1	4.3	23398	10.6	2.9	25248	7.6	1.4	28679	4.3	35000		15
404.1	3.7	21596	8.4	2.5	22424	5.8	1.2	23862	3.1	35000		
435.6	3.4	24434	8.8	2.3	26347	6.3	1.1	29898	3.6	35000		
505.6	3.0	25123	7.8	2.0	27079	5.6	0.99	30710	3.2	35000		
545.3	2.8	25479	7.3	1.8	27458	5.3	0.92	31129	3.0	35000		
632.9	2.4	26192	6.5	1.6	28215	4.7	0.79	31969	2.6	35000		
734.5	2.0	26921	5.8	1.4	28989	4.1	0.68	32828	2.3	35000		
802.1	1.9	24715	4.8	1.2	26640	3.5	0.62	30214	2.0	35000		
887.5	1.7	27870	4.9	1.1	29998	3.5	0.56	33947	2.0	35000		
969.1	1.5	25599	4.2	1.0	27579	3.0	0.52	31257	1.7	35000		
1125	1.3	26312	3.7	0.89	28337	2.6	0.44	32098	1.5	35000		
1275	1.2	26928	3.3	0.78	28991	2.4	0.39	32823	1.3	35000		
1382	1.1	22478	2.6	0.72	23391	1.8	0.36	27360	1.0	35000		
1541	0.97	27875	2.8	0.65	29998	2.0	0.32	33941	1.2	35000		
1862	0.81	28850	2.4	0.54	31034	1.7	0.27	35091	0.99	35000		
1938	0.77	23238	1.9	0.52	25230	1.4	0.26	29497	0.80	35000		
2341	0.64	23986	1.6	0.43	26352	1.2	0.21	30741	0.69	35000		
2744	0.55	24527	1.4	0.36	26399	1.0	0.18	29876	0.57	35000		

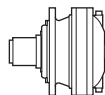

$i_{eff}$	1500			1000			500			$T_{2max}$ [Nm]	$P_T$ [kW]	
	$n_2$ [rpm]	$T_2$ [Nm]	$P_2$ [kW]	$n_2$ [rpm]	$T_2$ [Nm]	$P_2$ [kW]	$n_2$ [rpm]	$T_2$ [Nm]	$P_2$ [kW]			
<b>ED 2255</b>												
16.48	91	18068	172	61	19971	127	30.3	23024	73	35000	30	
20.40	74	19261	148	49.0	20892	107	24.5	24007	62	35000		
23.47	64	19862	133	42.6	21505	96	21.3	24665	55	35000		
25.86	58	18698	114	38.7	19755	80	19.3	22677	45.9	35000		
27.96	54	18857	106	35.8	20067	75	17.9	21864	41.0	35000		
29.75	50	18947	100	33.6	20327	72	16.8	23298	41.0	35000		
30.30	49.5	15214	79	33.0	16013	55	16.5	18421	31.8	35000		
35.43	42.3	19390	86	28.2	21054	62	14.1	24089	35.6	35000		
41.52	36.1	15712	59	24.1	17082	43.1	12.0	19587	24.7	35000		
44.54	33.7	18250	64	22.5	19413	45.6	11.2	21210	24.9	35000		
52.20	28.7	16478	49.6	19.2	17885	35.9	9.6	20467	20.5	35000		
<b>ET 3255</b>												
57.69	26.0	23732	65	17.3	25655	46.6	8.7	29185	26.5	35000		20
68.08	22.0	24505	57	14.7	26468	40.7	7.3	30079	23.1	35000		
71.41	21.0	24732	54	14.0	26706	39.2	7.0	30341	22.2	35000		
84.26	17.8	25525	47.6	11.9	27543	34.2	5.9	31262	19.4	35000		
90.50	16.6	23361	40.5	11.1	25228	29.2	5.5	28676	16.6	35000		
105.5	14.2	26630	39.7	9.5	28709	28.5	4.7	32548	16.2	35000		
115.5	13.0	22627	30.8	8.7	23567	21.4	4.3	27025	12.3	35000		
122.4	12.3	27380	35.1	8.2	29502	25.2	4.1	33424	14.3	35000		
144.5	10.4	23151	25.2	6.9	24425	17.7	3.5	28327	10.3	35000		
155.1	9.7	25866	26.2	6.4	27880	18.8	3.2	31607	10.7	35000		
183.2	8.2	26677	22.9	5.5	28739	16.4	2.7	32558	9.3	35000		
202.7	7.4	24063	18.7	4.9	26286	13.6	2.5	30363	7.8	35000		
230.3	6.5	22539	15.4	4.3	23776	10.8	2.2	27955	6.4	35000		
256.9	5.8	28388	17.4	3.9	30553	12.5	1.9	34568	7.0	35000		
267.3	5.6	22898	13.5	3.7	24642	9.7	1.9	28905	5.7	35000		
322.9	4.6	23390	11.4	3.1	25767	8.4	1.5	30142	4.9	35000		
<b>EQ 4255</b>												
346.1	4.3	33074	15.0	2.9	35537	10.8	1.4	40106	6.1	35000	15	
404.1	3.7	27914	10.9	2.5	30344	7.9	1.2	34832	4.5	35000		
435.6	3.4	34452	12.4	2.3	37000	8.9	1.1	41729	5.0	35000		
505.6	3.0	35370	11.0	2.0	37975	7.9	0.99	42810	4.4	35000		
545.3	2.8	35845	10.3	1.8	38479	7.4	0.92	43370	4.2	35000		
632.9	2.4	36794	9.1	1.6	39487	6.5	0.79	44488	3.7	35000		
734.5	2.0	37764	8.1	1.4	40518	5.8	0.68	45632	3.3	35000		
802.1	1.9	34813	6.8	1.2	37377	4.9	0.62	42138	2.8	35000		
887.5	1.7	39029	6.9	1.1	41862	4.9	0.56	47123	2.8	35000		
969.1	1.5	35990	5.8	1.0	38628	4.2	0.52	43526	2.4	35000		
1125	1.3	36940	5.2	0.89	39637	3.7	0.44	44647	2.1	35000		
1275	1.2	37759	4.7	0.78	40508	3.3	0.39	45614	1.9	35000		
1382	1.1	32556	3.7	0.72	35469	2.7	0.36	40872	1.5	35000		
1541	0.97	39021	4.0	0.65	41849	2.8	0.32	47103	1.6	35000		
1862	0.81	40320	3.4	0.54	43230	2.4	0.27	48635	1.4	35000		
1938	0.77	34973	2.8	0.52	38035	2.1	0.26	43718	1.2	35000		
2341	0.64	36379	2.4	0.43	39528	1.8	0.21	45375	1.0	35000		
2744	0.55	34358	2.0	0.36	36851	1.4	0.18	41484	0.79	35000		

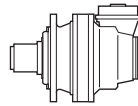

$i_{eff}$	1500			1000			500			$T_{2max}$ [Nm]	$P_T$ [kW]
	$n_2$ [rpm]	$T_2$ [Nm]	$P_2$ [kW]	$n_2$ [rpm]	$T_2$ [Nm]	$P_2$ [kW]	$n_2$ [rpm]	$T_2$ [Nm]	$P_2$ [kW]		

### EC 3255

49.45	30.3	11152	35.4	20.2	12595	26.7	10.1	15506	16.4	35000	
61.21	24.5	13803	35.4	16.3	15589	26.7	8.2	19192	16.4	35000	
70.42	21.3	15809	35.3	14.2	17854	26.6	7.1	21286	15.8	35000	
77.57	19.3	15705	31.8	12.9	17736	23.9	6.4	19507	13.2	35000	
94.26	15.9	9225	15.4	10.6	10418	11.6	5.3	12826	7.1	35000	
96.51	15.5	9445	15.4	10.4	10667	11.6	5.2	13133	7.1	35000	14
108.4	13.8	10613	15.4	9.2	11986	11.6	4.6	14757	7.1	35000	
129.2	11.6	12641	15.4	7.7	14276	11.6	3.9	17576	7.1	35000	
137.4	10.9	13451	15.4	7.3	15190	11.6	3.6	18702	7.1	35000	
163.7	9.2	16020	15.4	6.1	18093	11.6	3.1	22275	7.1	35000	
205.8	7.3	18340	14.0	4.9	19217	9.8	2.4	20710	5.3	35000	

### EC 4255

266.5	5.6	22261	13.1	3.8	24043	9.4	1.9	27344	5.4	35000	
314.5	4.8	22976	11.5	3.2	24801	8.3	1.6	28183	4.7	35000	
346.4	4.3	21283	9.7	2.9	22108	6.7	1.4	23539	3.6	35000	
389.3	3.9	23922	9.7	2.6	25805	6.9	1.3	29296	3.9	35000	
456.9	3.3	24653	8.5	2.2	26580	6.1	1.1	30156	3.5	35000	
487.3	3.1	24951	8.0	2.1	26897	5.8	1.0	30507	3.3	35000	
565.5	2.7	25652	7.1	1.8	27641	5.1	0.88	31333	2.9	35000	
650.7	2.3	26327	6.4	1.5	28358	4.6	0.77	32127	2.6	35000	
683.4	2.2	26566	6.1	1.5	28612	4.4	0.73	32409	2.5	35000	10
786.2	1.9	27259	5.4	1.3	29348	3.9	0.64	33227	2.2	35000	
936.4	1.6	23322	3.9	1.1	24430	2.7	0.53	28240	1.6	35000	
982.1	1.5	25662	4.1	1.0	27646	2.9	0.51	31331	1.7	35000	
1064	1.4	21898	3.2	0.94	22800	2.2	0.47	25781	1.3	35000	
1187	1.3	26573	3.5	0.84	28615	2.5	0.42	32406	1.4	35000	
1492	1.0	22649	2.4	0.67	23732	1.7	0.34	27836	0.98	35000	
1748	0.86	22577	2.0	0.57	24326	1.5	0.29	27574	0.83	35000	

**1500**  
HOURS LIFE

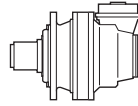

**255**

$i_{eff}$	1500			1000			500			$T_{2max}$ [Nm]	$P_T$ [kW]
	$n_2$ [rpm]	$T_2$ [Nm]	$P_2$ [kW]	$n_2$ [rpm]	$T_2$ [Nm]	$P_2$ [kW]	$n_2$ [rpm]	$T_2$ [Nm]	$P_2$ [kW]		

**EC 3255**

49.45	30.3	19703	63	20.2	22252	47.1	10.1	27395	29.0	35000	
61.21	24.5	24007	62	16.3	25944	44.4	8.2	29502	25.2	35000	
70.42	21.3	24665	55	14.2	26637	39.6	7.1	30264	22.5	35000	
77.57	19.3	22677	45.9	12.9	24506	33.1	6.4	27880	18.8	35000	
94.26	15.9	16298	27.2	10.6	18406	20.5	5.3	22661	12.6	35000	
96.51	15.5	16688	27.2	10.4	18846	20.5	5.2	23203	12.6	35000	14
108.4	13.8	18751	27.2	9.2	21177	20.5	4.6	26072	12.6	35000	
129.2	11.6	22334	27.2	7.7	23823	19.3	3.9	27670	11.2	35000	
137.4	10.9	23764	27.2	7.3	26838	20.5	3.6	30928	11.8	35000	
163.7	9.2	26126	25.1	6.1	28155	18.0	3.1	31911	10.2	35000	
205.8	7.3	22267	17.0	4.9	23244	11.8	2.4	27250	6.9	35000	

**EC 4255**

266.5	5.6	31562	18.6	3.8	33932	13.3	1.9	38327	7.5	35000	
314.5	4.8	32512	16.2	3.2	34941	11.6	1.6	39446	6.6	35000	
346.4	4.3	27025	12.3	2.9	29404	8.9	1.4	33795	5.1	35000	
389.3	3.9	33772	13.6	2.6	36278	9.8	1.3	40928	5.5	35000	
456.9	3.3	34744	11.9	2.2	37310	8.6	1.1	42073	4.8	35000	
487.3	3.1	35142	11.3	2.1	37733	8.1	1.0	42541	4.6	35000	
565.5	2.7	36075	10.0	1.8	38724	7.2	0.88	43641	4.0	35000	
650.7	2.3	36973	8.9	1.5	39678	6.4	0.77	44699	3.6	35000	
683.4	2.2	37291	8.6	1.5	40016	6.1	0.73	45075	3.5	35000	
786.2	1.9	38215	7.6	1.3	40997	5.5	0.64	46164	3.1	35000	10
936.4	1.6	33107	5.6	1.1	35844	4.0	0.53	40917	2.3	35000	
982.1	1.5	36074	5.8	1.0	38717	4.1	0.51	43626	2.3	35000	
1064	1.4	30767	4.5	0.94	33571	3.3	0.47	38769	1.9	35000	
1187	1.3	37288	4.9	0.84	40007	3.5	0.42	45057	2.0	35000	
1492	1.0	33094	3.5	0.67	36040	2.5	0.34	41505	1.5	35000	
1748	0.86	31760	2.9	0.57	34089	2.0	0.29	38417	1.2	35000	

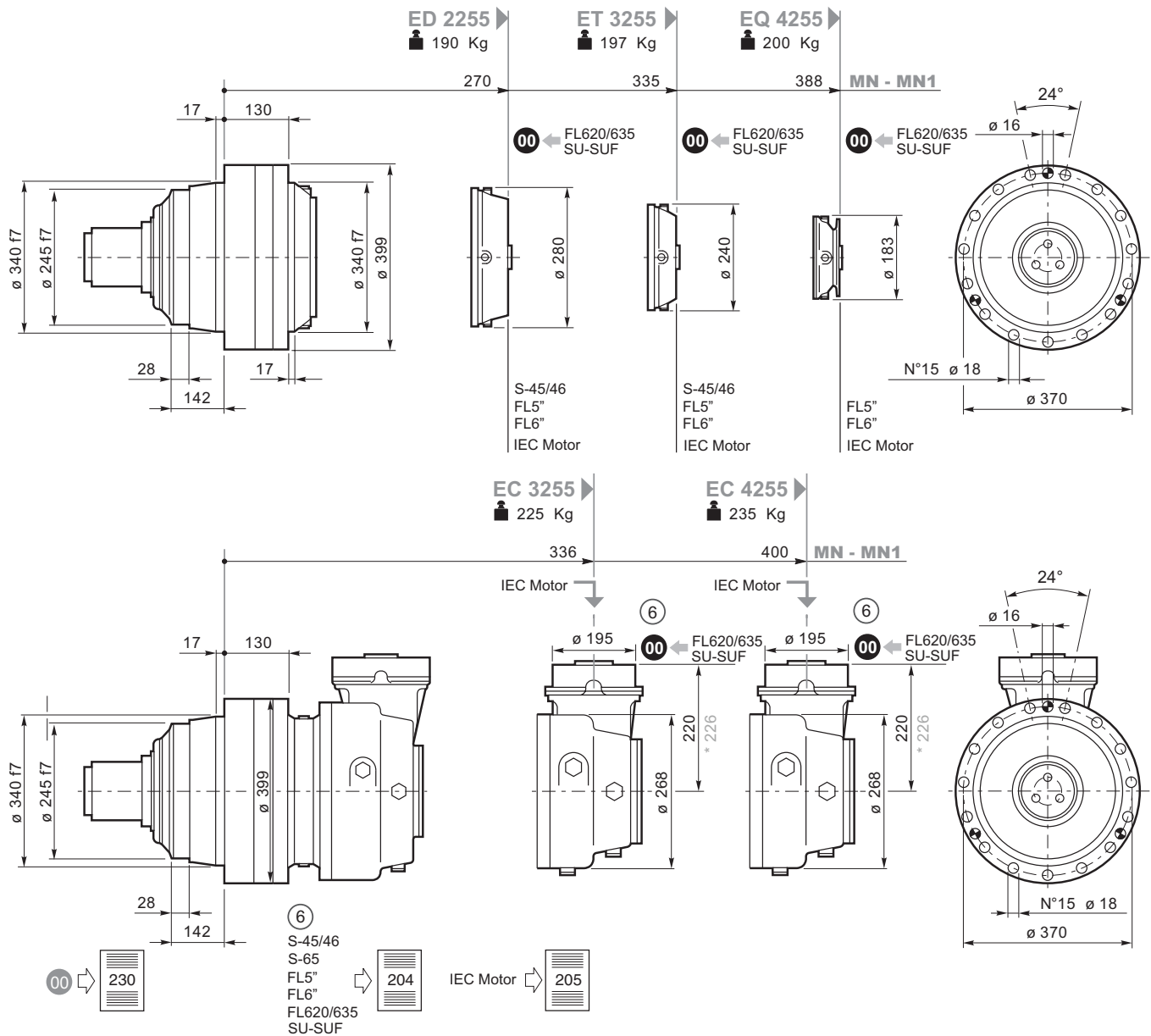
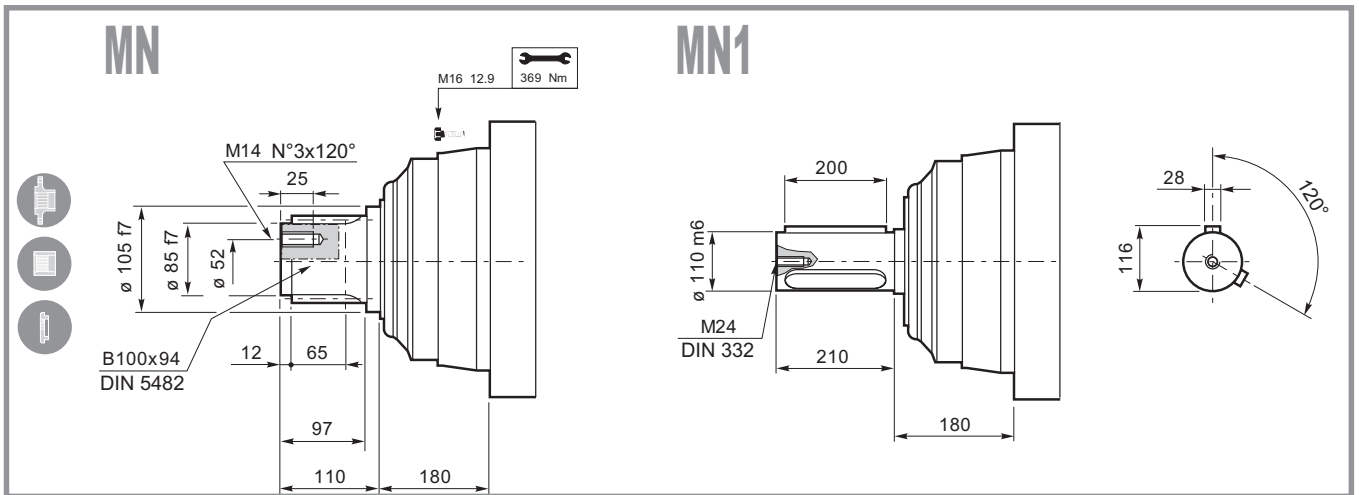

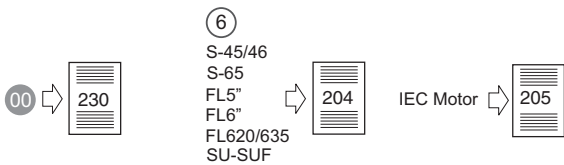
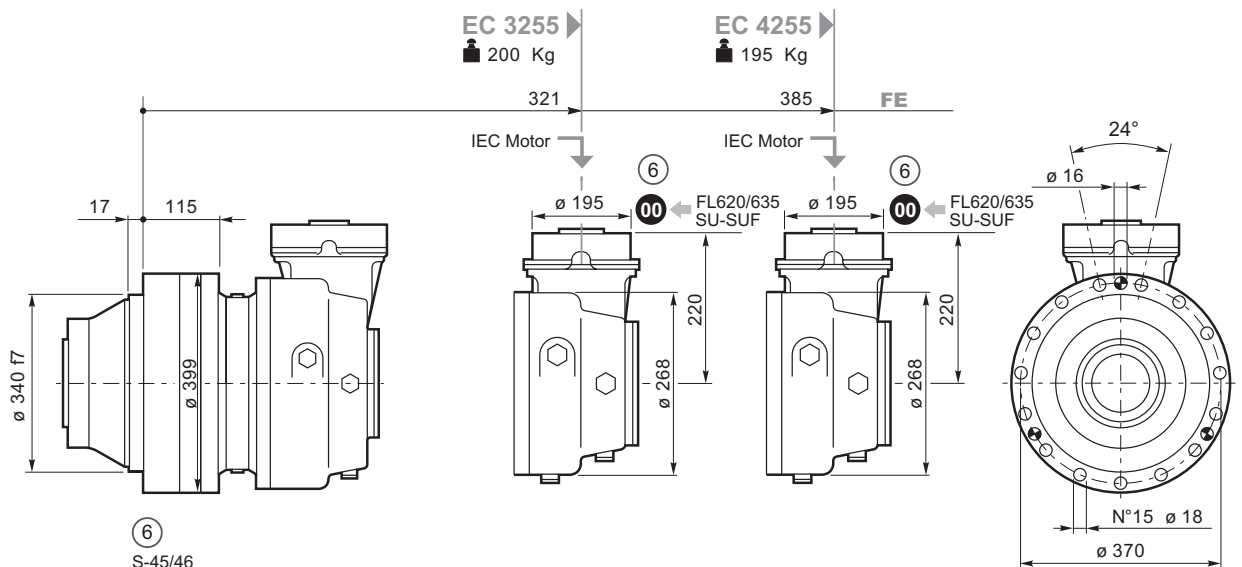
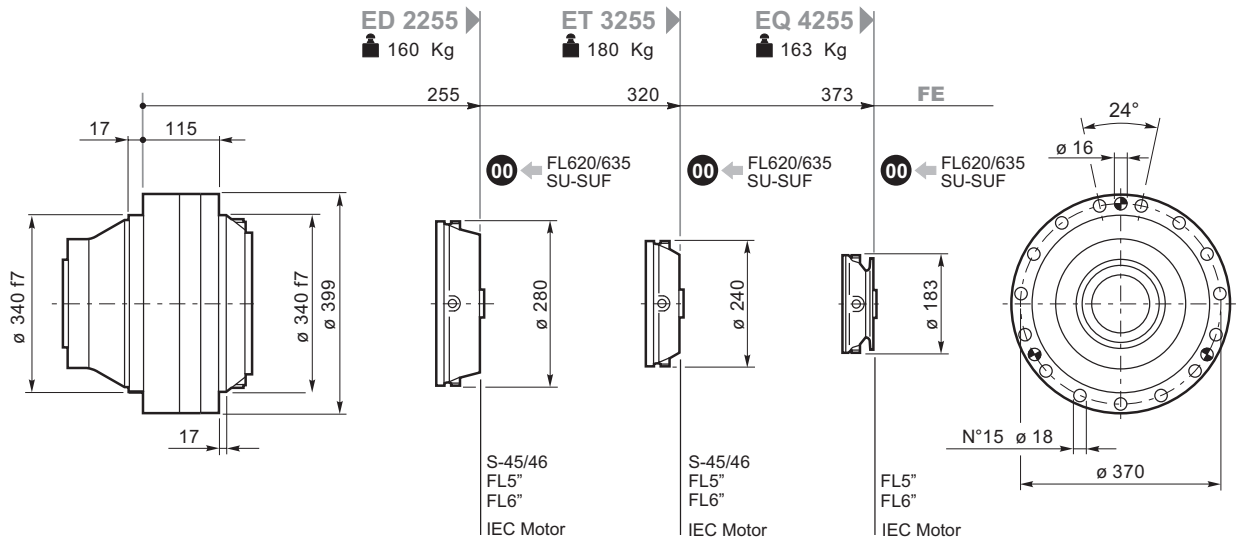
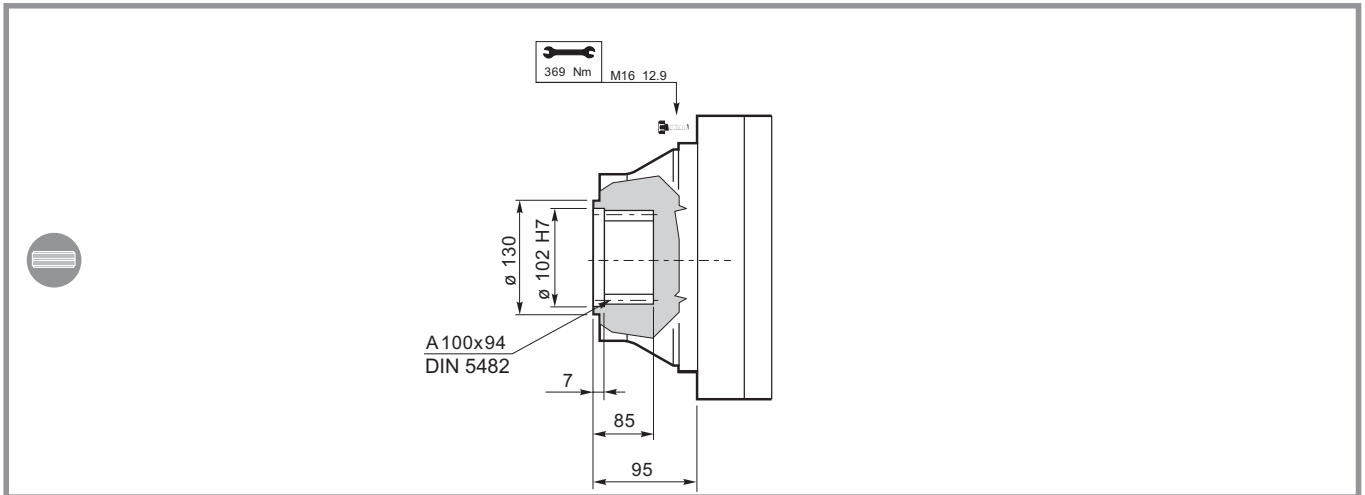



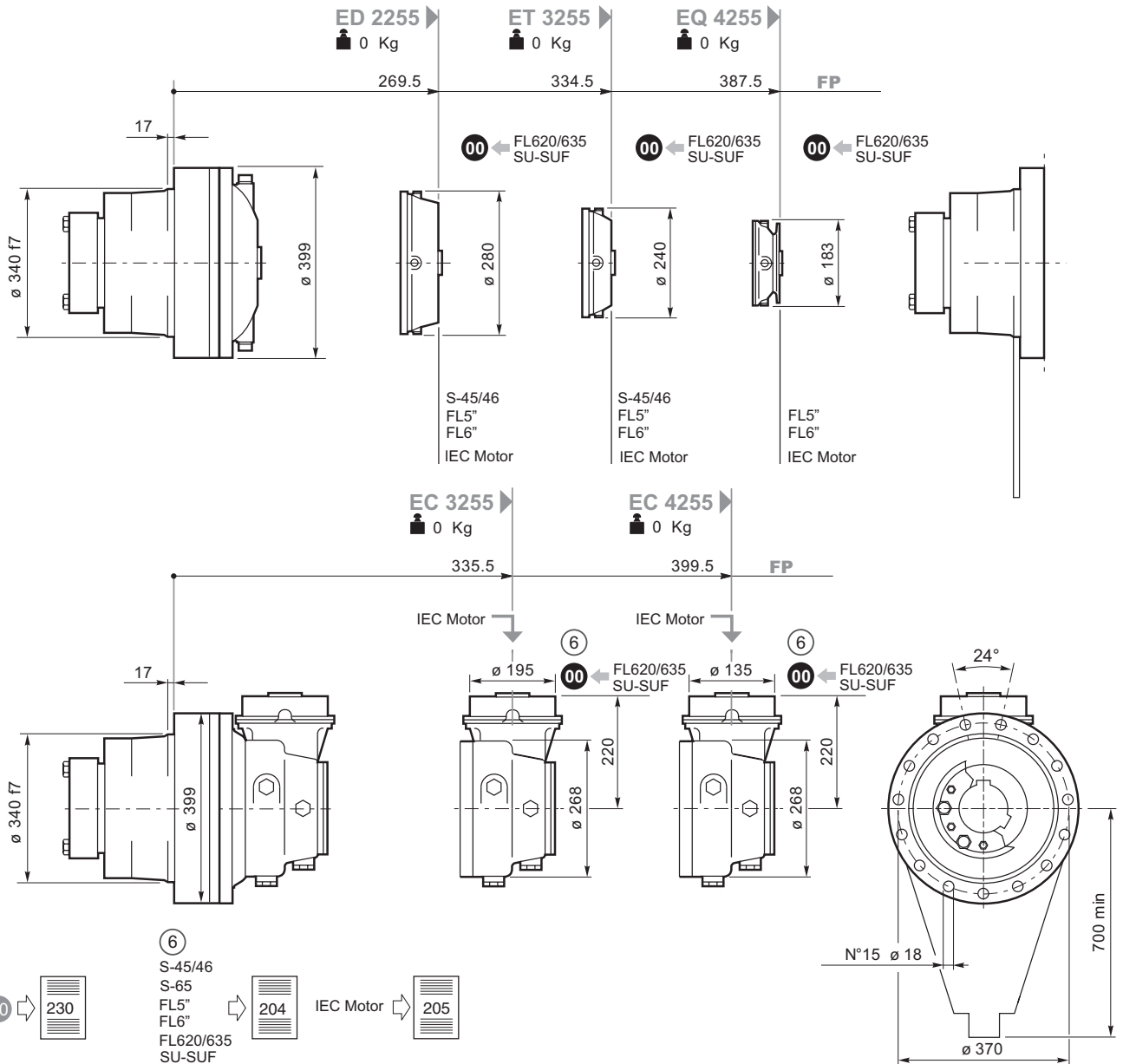
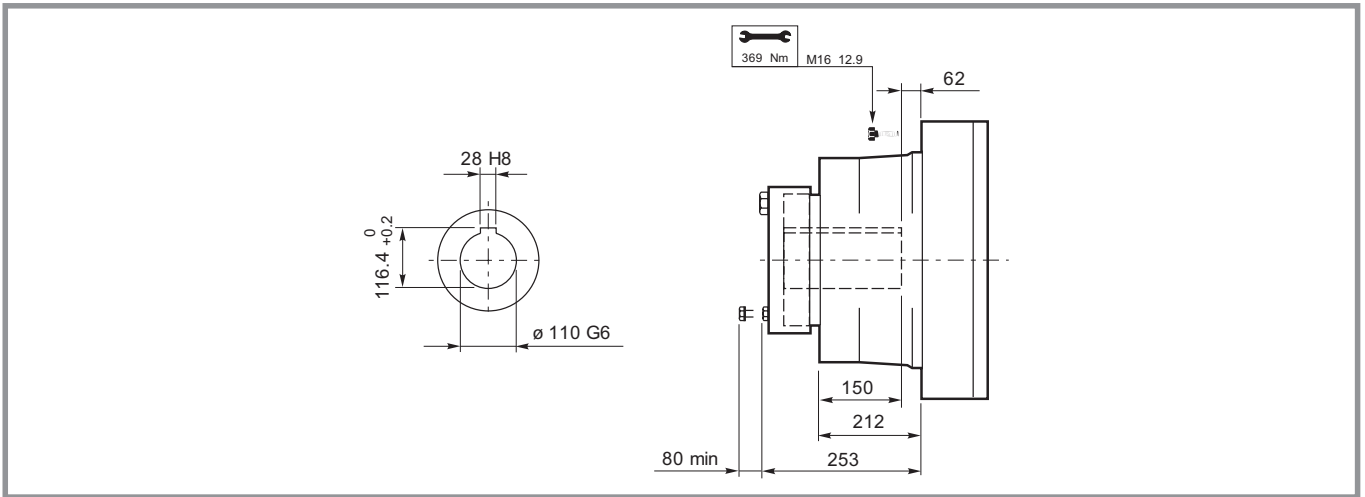



## S45CR1-S46C1

## S65CR1

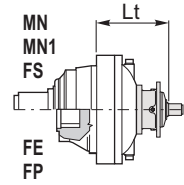
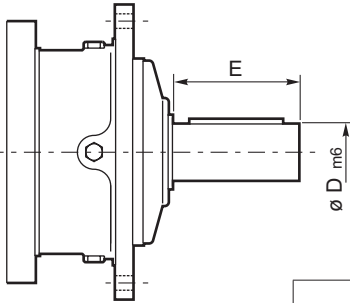

	D m6	E	Lt			
			MN-MN1-FS	FE	FP	
<b>S45 CR1</b>	65	105	<b>ED 2255</b>	411.5	396.5	411
			<b>ET 3255</b>	411.5	396.5	411
			<b>EQ 4255</b>	478	463	477.5
<b>S46 C1</b>	65	105	<b>ED 2255</b>	452.5	437.5	452
			<b>ET 3255</b>	452.5	437.5	452
			<b>EQ 4255</b>	519	504	518.5
<b>S65 CR1</b>	80	130	<b>ED 2255</b>	450.5	433.5	450

## SU2

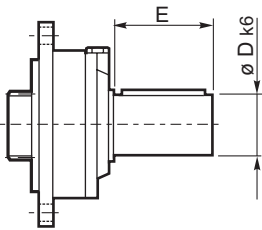

	D k6	E	Lt			
			MN-MN1 FS	FE	FP	
<b>SU 2</b>	40	58	<b>ET 3255</b>	395	380	394.5
			<b>EQ 4255</b>	448	433	447.5

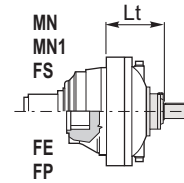

## ⑥ 48.82

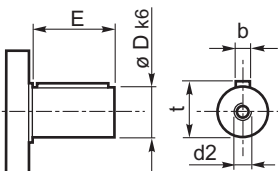

	D	E	Lt	
			MN-MN1-FS-FE-FP	
<b>48.82</b>	48	82	<b>EC 3255</b>	280
			<b>EC 4255</b>	280

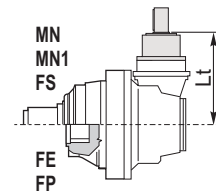

## FL250-FL350-FL450 FL750 FL760-FL960

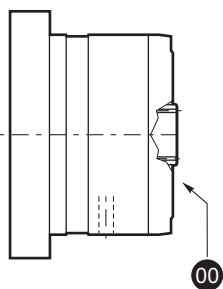

		Lt		
		MN-MN1-FS	FE	FP
FL250-FL350 FL450	ED 2255	381.5	366.5	—
	ET 3255	442	427	—
	EQ 4255	509.5	594.5	—
	EC 3255	280	280	280
	EC 4255	280	280	280
FL750	ED 2255	394.5	380	—
	ET 3255	455	440.5	—
	EQ 4255	522.5	507	—
	EC 3255	293	293	293
FL760-FL960	ED 2255	293	293	293
	ED 2255	409	394	—

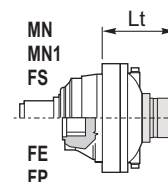

**FL620/10  
FL635/10**

**FL620U-FL635U**

SAE A-AA  
Shaft FE

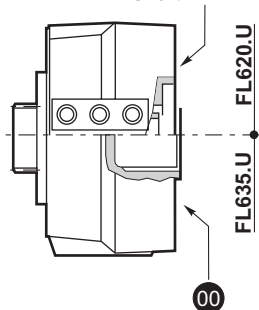

		Lt		
		MN-MN1-FS	FE	FP
FL620/U	ED 2255			
	ET 3255			
	EQ 4255			
	EC 3255	324.5	324.5	324.5
	EC 3255*	330.5	330.5	330.5
	EC 4255	324.5	324.5	324.5
	EC 4255*	330.5	330.5	330.5
FL635/U	ED 2255	372.5	357.5	360.5
	ET 3255	439.5	424.5	425.5
	EQ 4255	507	492	478.5
	EC 3255	311	311	311
	EC 3255*	317	317	317
	EC 4255	311	311	311
	EC 4255*	317	317	317
FL620/10	EQ 4255	480	465	452
FL635/10	EQ 4255	461	446	433

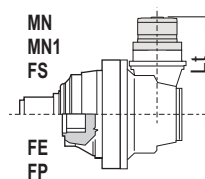

\* (bg)

198

## IEC Motor

		Lt							
		IEC 63	IEC 71	IEC 80 90	IEC 100 112	IEC 132	IEC 160 180	IEC 200	IEC 225
ED 2255	MN-MN1-FS-FP	301.5	303.5	308.5	309.5	376.5		420.5	448.5
ED 2255	FE	286.5	288.5	293.5	294.5	361.5		405.5	433.5
ET 3255	MN-MN1-FS-FP	368.5	370.5	375.5	376.5	453.5	474.5	484.5	515.5
ET 3255	FE	353.5	355.5	360.5	361.5	438.5	459.5	468.5	499.5
EQ 4255	MN-MN1-FS-FP	436	438	443	444	511	542	552	
EQ 4255	FE	421	423.5	428.5	429.5	496	527	537	
EC 3255	MN-MN1-FE-FS-FP	240	242	247	248	315	346	356	387
EC 4255	MN-MN1-FE-FS-FP	240	242	247	248	315	346	356	387

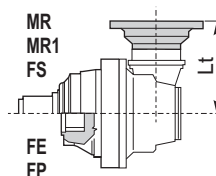
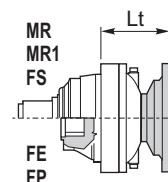



**Flangia ruota**  
**Driving flange**  
**Radnabenflansch**  
**Flasque de roue**  
**Brida de la rueda**  
**Flange de roda**

## FA 250

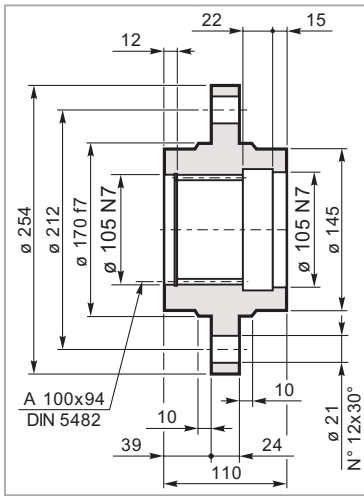

Mat. C40 UNI EN 10083  
 Code: 34702921800



**Flangia ruota**  
**Driving flange**  
**Radnabenflansch**  
**Flasque de roue**  
**Brida de la rueda**  
**Flange de roda**

## FR 250

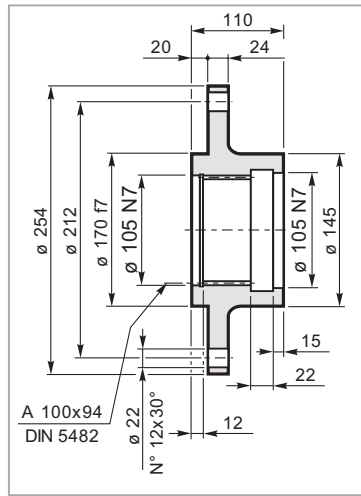

Mat. C40 UNI EN 10083  
 Code: 34703021800



**Manicotto scanalato**  
**Splined bush**  
**Keilmuffe**  
**Manchon cannelée**  
**Manguito acanalado**  
**Luva ranhurada**

## MS 250

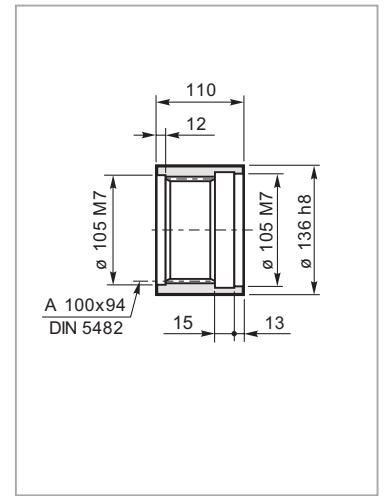

Mat. 39NiCrMo3 UNI EN 10083  
 Code: 39105140600



**Rondella di fermo**  
**Shaft cover**  
**Gegenscheibe**  
**Rondelle frein**  
**Arandela de bloqueo**  
**Amuela de encosto**

## RDF 250

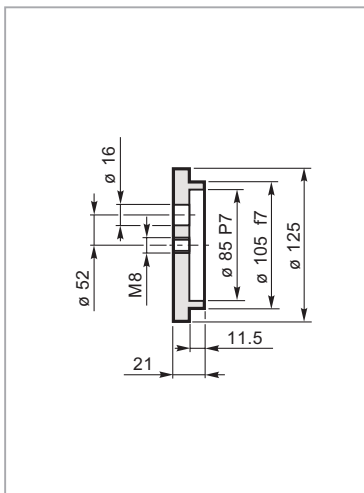

Mat. C40 UNI EN 10083  
 Code: 37201240800



**Barra scanalata**  
**Splined bar**  
**Zugspindel**  
**Barre cannelée**  
**Barra acanalada**  
**Barra ranhurada**

## BS 250

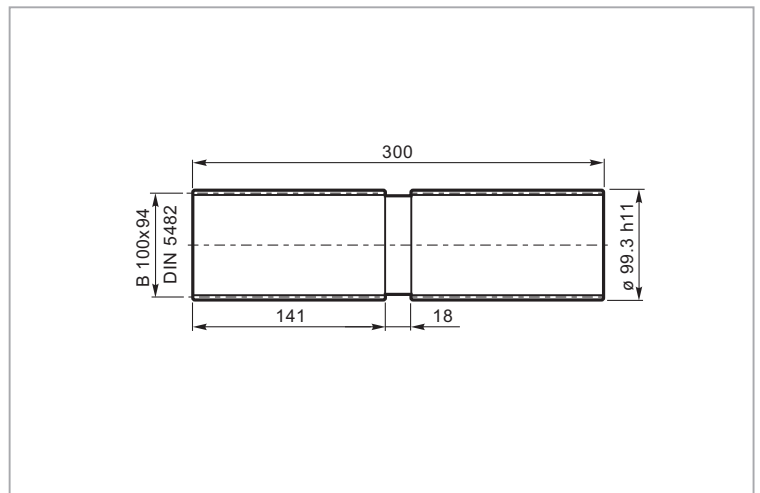

Mat. 39NiCrMo3 UNI EN 10083  
 Code: 39127330100

Carichi radiali sugli alberi uscita / Radial loads on output shafts  
 Radiallasten auf de Abtriebswellen / Charges radiales sur les arbres de sortie  
 Cargas sobre los ejes de salida / Cargas radiais nos eixos de saida

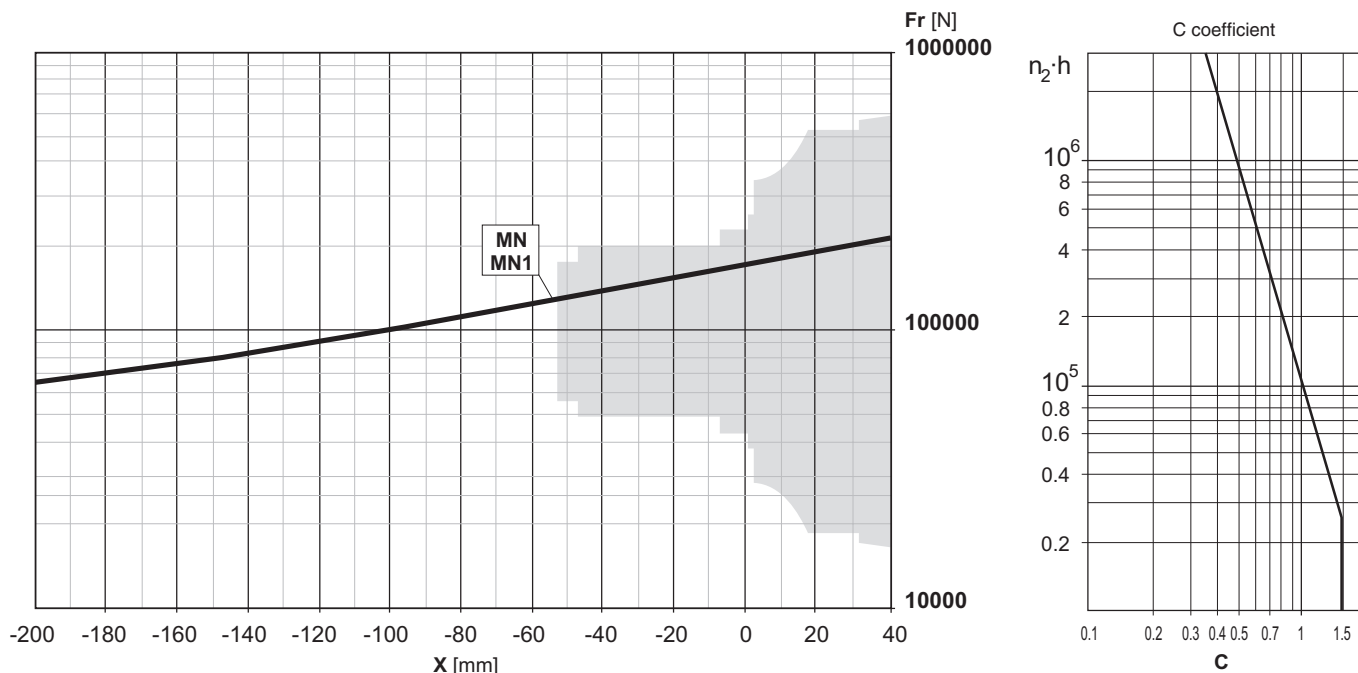

Carichi assiali / Axial loads / Axialkräfte / Charges axiales / Cargas axiales / Forças axiais

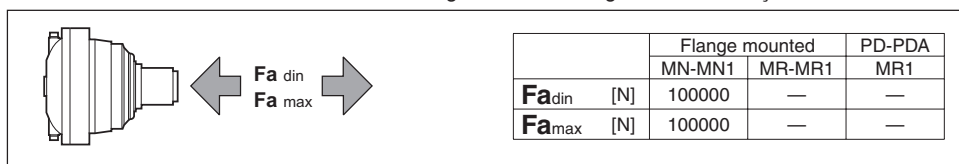

Carichi radiali sugli alberi entrata / Radial loads on input shafts  
 Radiallasten auf de Antriebswellen / Charges radiales sur les arbres d'entrée  
 Cargas sobre los ejes de entrada / Cargas radiais nos eixos de entrada

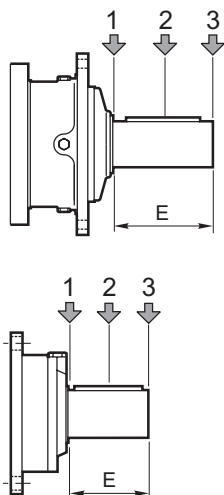

Type	E	$Fr$ [N]					
		$n_1 \cdot h = 10^7$			$n_1 \cdot h = 10^8$		
		1	2	3	1	2	3
S45 CR1	105	10000	6000	4000	5000	3000	2000
S46 C1	105	14000	8800	6400	7000	4400	3200
S65 CR1	130	23800	15500	9600	11900	7800	4800

Type	E	$Fr$ [N]					
		$n_1 \cdot h = 10^7$			$n_1 \cdot h = 10^8$		
		1	2	3	1	2	3
SU2	58	3000	2000	1500	1400	1000	700

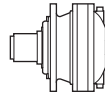

$i_{\text{eff}}$	1500			1000			500			$T_{2\text{max}}$ [Nm]	$P_T$ [kW]
	$n_2$ [rpm]	$T_2$ [Nm]	$P_2$ [kW]	$n_2$ [rpm]	$T_2$ [Nm]	$P_2$ [kW]	$n_2$ [rpm]	$T_2$ [Nm]	$P_2$ [kW]		
<b>ED 2320</b>											
19.95	75	14059	111	50	15877	83	25.1	19547	51	35000	30
24.69	61	14935	95	40.5	16867	72	20.2	20766	44.0	35000	
28.41	53	15269	84	35.2	17244	64	17.6	21229	39.1	35000	
33.84	44.3	15877	74	29.6	17931	55	14.8	22076	34.2	35000	
42.54	35.3	14027	52	23.5	15048	37.0	11.8	16606	20.4	35000	
<b>ET 3320</b>											
69.83	21.5	20472	46.1	14.3	23121	34.7	7.2	24587	18.4	35000	20
82.40	18.2	21515	41.0	12.1	23517	29.9	6.1	24927	15.8	35000	
86.43	17.4	21749	39.5	11.6	23613	28.6	5.8	25025	15.2	35000	
103.2	14.5	23014	35.0	9.7	23971	24.3	4.8	25693	13.0	35000	
117.3	12.8	23367	31.3	8.5	24232	21.6	4.3	26359	11.8	35000	
127.7	11.8	23582	29.0	7.8	24404	20.0	3.9	26802	11.0	35000	
148.2	10.1	23883	25.3	6.8	24708	17.5	3.4	27598	9.8	35000	
170.5	8.8	24167	22.3	5.9	24997	15.4	2.9	28362	8.7	35000	
179.0	8.4	24267	21.3	5.6	25098	14.7	2.8	28634	8.4	35000	
206.0	7.3	24553	18.7	4.9	25685	13.1	2.4	29420	7.5	35000	
245.3	6.1	24442	15.7	4.1	25441	10.9	2.0	27149	5.8	35000	

**1500**  
HOURS LIFE

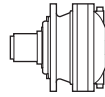

**320**

$i_{\text{eff}}$	1500			1000			500			$T_{2\text{max}}$ [Nm]	$P_T$ [kW]
	$n_2$ [rpm]	$T_2$ [Nm]	$P_2$ [kW]	$n_2$ [rpm]	$T_2$ [Nm]	$P_2$ [kW]	$n_2$ [rpm]	$T_2$ [Nm]	$P_2$ [kW]		
<b>ED 2320</b>											
<b>19.95</b>	75	23238	183	50	24201	127	25.1	26873	71	35000	30
<b>24.69</b>	61	23751	151	40.5	24693	105	20.2	28052	59	35000	
<b>28.41</b>	53	24080	133	35.2	25055	92	17.6	28844	53	35000	
<b>33.84</b>	44.3	22824	106	29.6	24289	75	14.8	26464	41.0	35000	
<b>42.54</b>	35.3	17430	64	23.5	18541	45.6	11.8	20257	24.9	35000	
<b>ET 3320</b>											
<b>69.83</b>	21.5	27722	62	14.3	30034	45.0	7.2	34291	25.7	35000	20
<b>82.40</b>	18.2	28652	55	12.1	31014	39.4	6.1	35370	22.5	35000	
<b>86.43</b>	17.4	28923	53	11.6	31301	37.9	5.8	35686	21.6	35000	
<b>103.2</b>	14.5	29945	45.6	9.7	32379	32.9	4.8	36876	18.7	35000	
<b>117.3</b>	12.8	30704	41.1	8.5	33182	29.6	4.3	37763	16.9	35000	
<b>127.7</b>	11.8	31209	38.4	7.8	33716	27.7	3.9	38353	15.7	35000	
<b>148.2</b>	10.1	32113	34.0	6.8	34673	24.5	3.4	39412	13.9	35000	
<b>170.5</b>	8.8	32982	30.4	5.9	35594	21.9	2.9	40430	12.4	35000	
<b>179.0</b>	8.4	33290	29.2	5.6	35920	21.0	2.8	40791	11.9	35000	
<b>206.0</b>	7.3	34182	26.1	4.9	36866	18.7	2.4	41838	10.6	35000	
<b>245.3</b>	6.1	29126	18.7	4.1	31816	13.6	2.0	36752	7.8	35000	



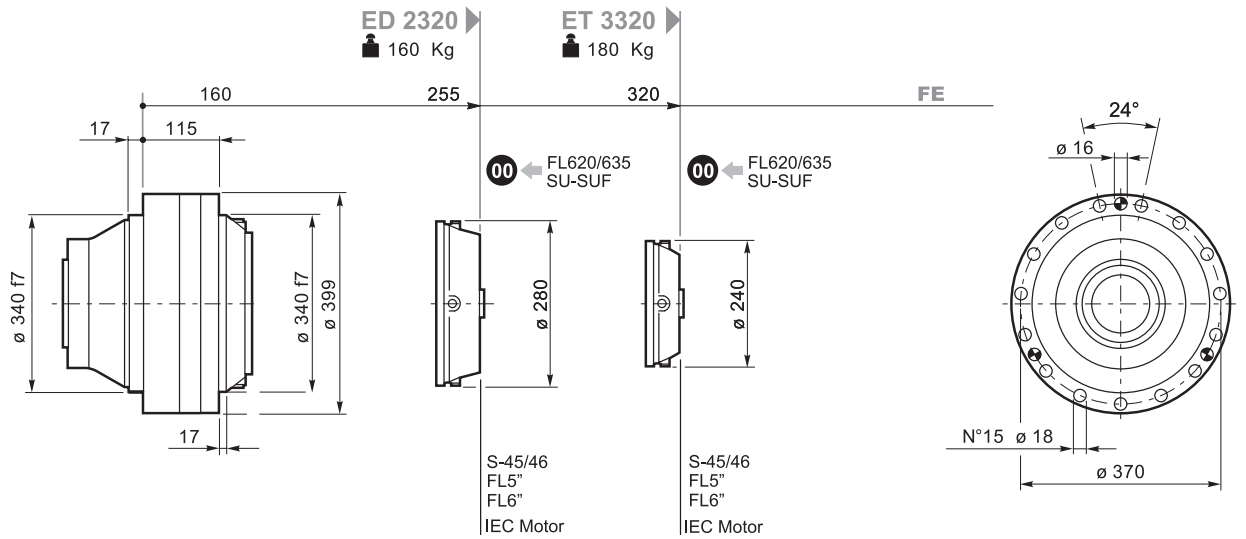
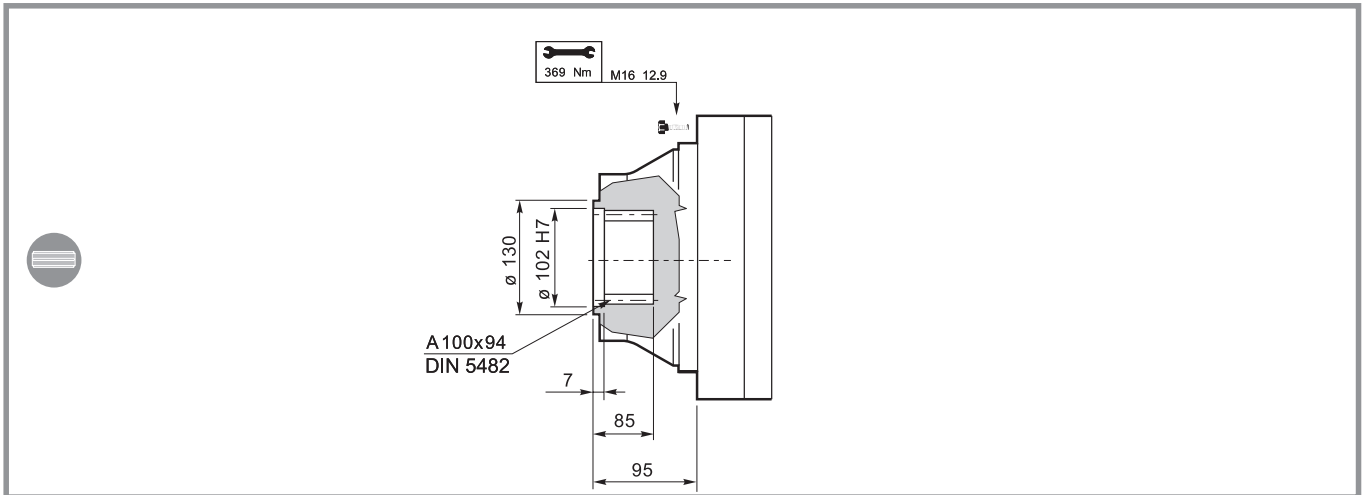

## S45CR1-S46C1

## S65CR1

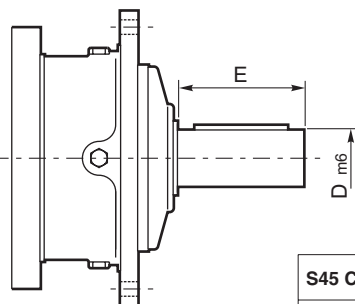

	D m6	E	Lt	
				FE
<b>S45 CR1</b>	65	105	<b>ED 2320</b>	383
			<b>ET 3320</b>	383
<b>S46 C1</b>	65	105	<b>ED 2320</b>	424
			<b>ET 3320</b>	424
<b>S65 CR1</b>	80	130	<b>ED 2320</b>	422

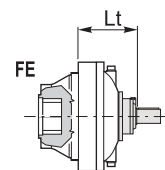

## SU2

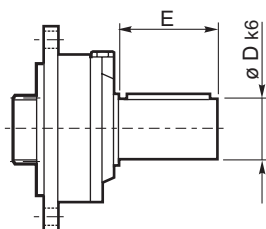

	D k6	E	Lt	
				FE
<b>SU 2</b>	40	58	<b>ET 3320</b>	380

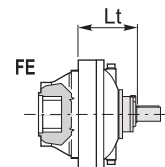

# 320

## FL250-FL350-FL450 FL750

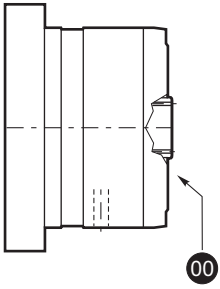

		Lt
		FE
FL250-FL350	ED 2320	414
	ET 3320	414
FL450	ED 2320	427
	ET 3320	427

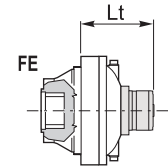

## FL620U-FL635U

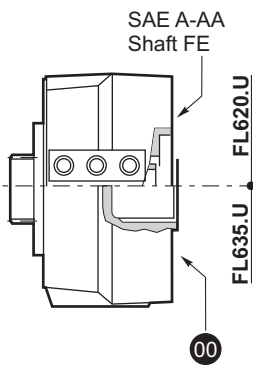

		Lt
		FE
FL620/U	ED 2320	359.5
	ET 3320	424.5
FL635U	ED 2320	346
	ET 3320	411

## IEC Motor

		Lt							
		IEC 63	IEC 71	IEC 80 90	IEC 100 112	IEC 132	IEC 160 180	IEC 200	IEC 225
ED 2320	FE	275	277	282	283	350		391	372
ET 3320	FE	340	342	347	348	415	446	456	438

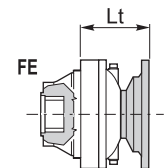



Barra scanalata  
Splined bar  
Zugspindel  
Barre cannelée  
Barra acanalada  
Barra ranhurada

## BS 250

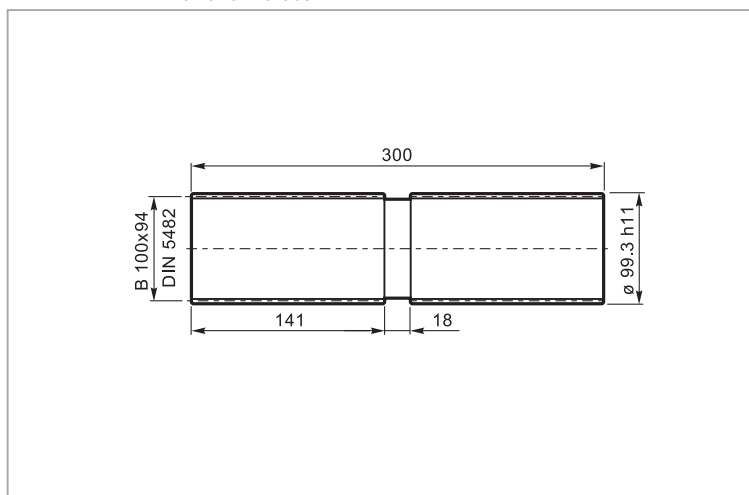

Mat. 39NiCrMo3 UNI EN 10083  
Code: 39127330100

Carichi radiali sugli alberi entrata / Radial loads on input shafts  
Radiallasten auf de Antriebswellen / Charges radiales sur les arbres d'entrée  
Cargas sobre los ejes de entrada / Cargas radiais nos eixos de entrada

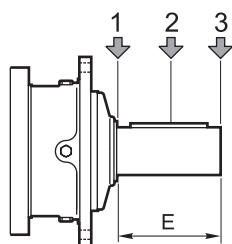

Type	E	Fr [N]					
		$n_1 \cdot h = 10^7$			$n_1 \cdot h = 10^8$		
		1	2	3	1	2	3
<b>S45 CR1</b>	105	10000	6000	4000	5000	3000	2000
<b>S46 C1</b>	105	14000	8800	6400	7000	4400	3200
<b>S65 CR1</b>	130	23800	15500	9600	11900	7800	4800

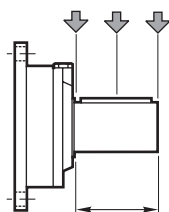

Type	E	Fr [N]					
		$n_1 \cdot h = 10^7$			$n_1 \cdot h = 10^8$		
		1	2	3	1	2	3
<b>SU2</b>	58	3000	2000	1500	1400	1000	700

**8. USCITE  
ENTRATE**  
**8. SORTIES  
ENTRÉES**

**8. OUTPUT  
INPUT**  
**8. SALIDAS  
ENTRADAS**

**8. ANTRIEBE  
ABTRIEBE**  
**8. SAÍDAS  
ENTRADAS**

**FE**

Flangia e albero cavo scanalato  
Sortie femelle cannelée

Mounting flange and female splined shaft  
Brida y eje ranurado hembra

Flansch und innenverzahnte Hohlwelle  
Flange e eixo vazado estriado

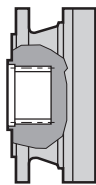

**010**

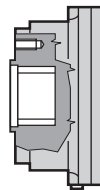

**020 - 091**

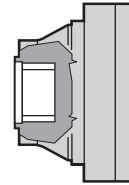

**150 - 320**

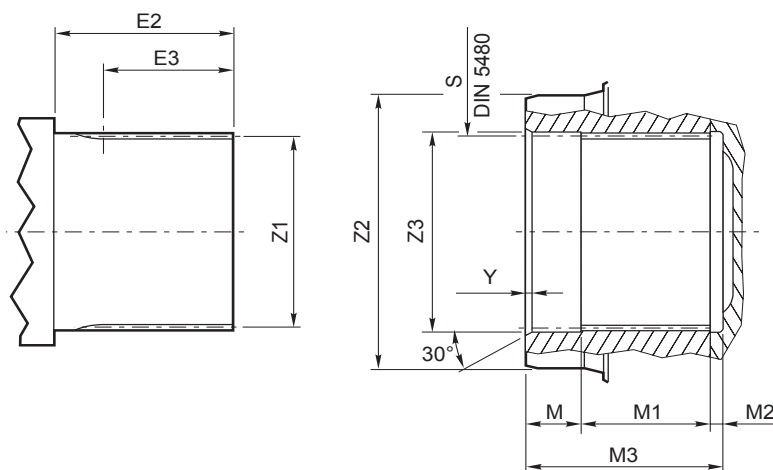

	M3	M	M1	M2	Y	S	Z2	Z3	Z1	E2	E3
<b>010</b>	34.7	5	24.7	5	0.5	A40x36 H10	50 f8	36 H11	B40x36 c9	32.7	22.7
<b>020</b>	51.5	8	43.6	-	1.0	A58x53 H10	75 f7	60 H7	B58x53 c9	49.5	41.5
<b>030</b>	44	8	36	-	1.5	A58x53 H10	75 f7	60 H7	B58x53 c9	42	34
<b>045</b>	44	8	36	-	1.5	A58x53 H10	75 f7	60 H7	B58x53 c9	42	34
<b>065-067</b>	67	9	50	8	1.0	A70x64 H10	90 g7	72 H7	B70x64 c9	65	48
<b>090-091</b>	75	5	62	8	1.0	A70x64 H10	90 h8	72 H7	B70x64 c9	73	60
<b>150-155</b>	77	7	70	-	1.5	A80x74 H10	100 f7	88 H7	B80x74 c9	75	68
<b>250-255</b>	85	7	78	-	1.5	A100x94 H10	130 f7	102 H7	B100x94 c9	83	76
<b>320</b>	85	7	78	-	1.5	A100x94 H10	130 f7	102 H7	B100x94 c9	83	76

# FS

Albero cavo per calettatore  
Sortie pour montage à fret

Shaft mounted  
Eje hembra para montaje

Schrumpfscheiben-Verbindung  
Eixo vazado para encaixe

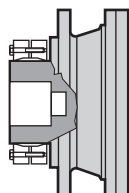

**010 - 091**

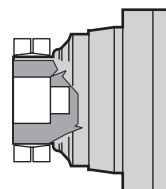

**150 - 255**

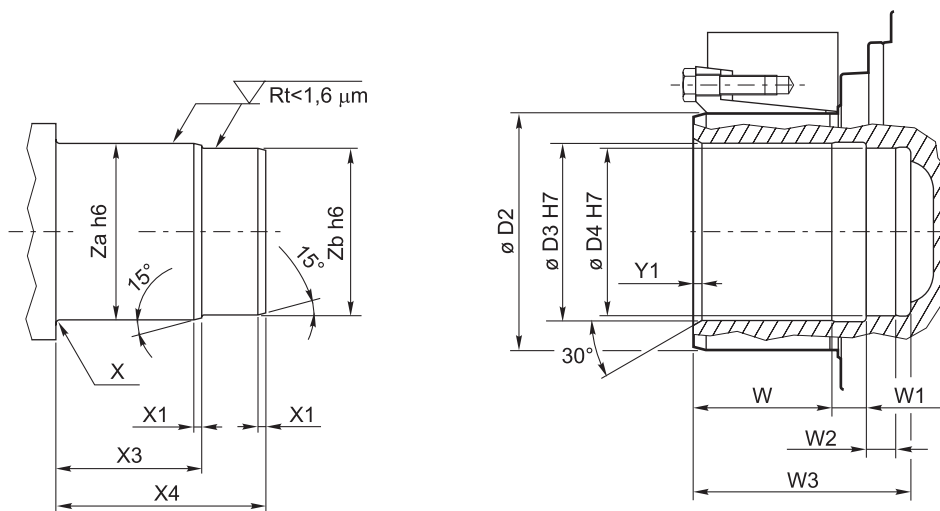

	W	W1	W2	W3	D2	D3	D4	Y1	X	X1	X3	X4	Za	Zb
<b>010</b>	29	9	10	50	65 f7	48 H7	30 f7	2	R 2	3	33	48	48	30
<b>020</b>	54	16	23	95	100 f7	75 H7	40 f7	2	R 2	3	52	92	75	40
<b>030</b>	54	16	23	95	100 f7	75 H7	40 f7	2	R 2	3	52	92	75	40
<b>045</b>	54	16	23	95	100 f7	75 H7	40 f7	2	R 2	3	52	92	75	40
<b>065-067</b>	80	20	33	135	125 f7	90 H7	50 f7	2	R 2	3	62	132	90	50
<b>090-091</b>	80	20	38	140	140 f7	100 H7	60 f7	2	R 2	3	69	135	100	60
<b>150-155</b>	79	6	47	135	165 f7	120 H7	80 f7	5	R 2	3	79	130	120	80
<b>250-255</b>	80	20	47	150	175V	130 H7	80 f7	1.5	R 1.5	5	81	145	130	80

Per la verifica dell'accoppiamento con il giunto vedi pag. 24

To check joint coupling see page 24

Für die Kontrolle der Verbindung der Kupplung, siehe Seite 24

Pour la vérification de l'accouplement avec le joint, voir page. 25

Para el control del acoplamiento con la unión, consultar pág. 25

Para verificar a ligação com o acoplamento, ver a pág. 25

# MN

Flangia e albero scanalato  
Sortie à arbre cannelé

Mounting flange and splined shaft  
Brida y eje ranurado

Flansch und Zahnwelle  
Flange e eixo estriado

# MR

Flangia e albero scanalato rinforzato  
Sortie renforcée à arbre cannelé

Mounting flange and heavy duty splined shaft  
Brida y eje ranurado reforzado

Flansch und verstärkt Zahnwelle  
Flange e eixo estriado reforçado

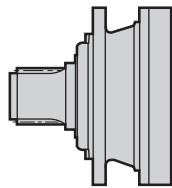

010 - 091

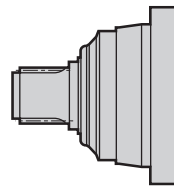

150 - 255

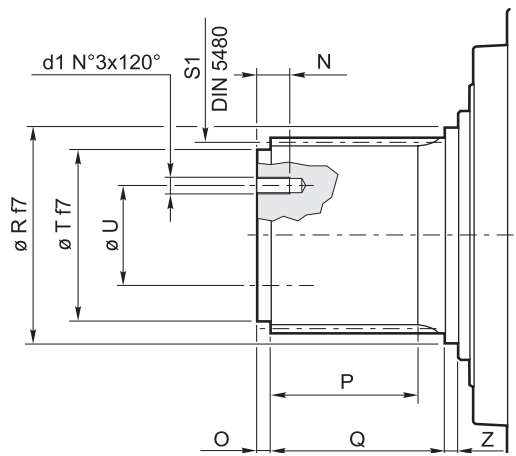
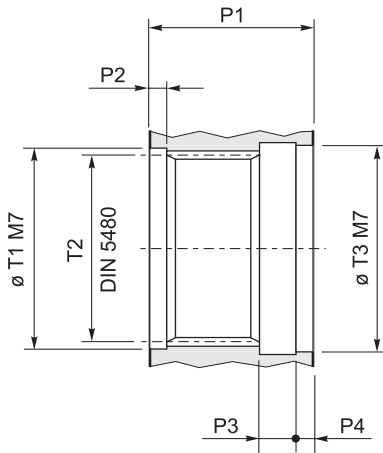

		d1	N	O	P	P1	P2	P3	P4	Q	R	S1	T	T1	T2	T3	U	Z
<b>010</b>	MN-MR	M6	20	5	30	55	5	14	7	43	42 f7	B40x36 c9	35 f7	42 M7	A40x36	42 M7	24	7
<b>020</b>	MR	M10	20	8	38	68	8	13	10	58	60 f7	B58x53 c9	50 f7	60 M7	A58x53	60 M7	32	8
<b>030</b>	MR	M10	20	8	38	68	8	13	10	58	60 f7	B58x53 c9	50 f7	60 M7	A58x53	60 M7	32	8
<b>040</b>	MN	M10	20	8	50	68	8	13	10	58	60 f7	B58x53 c9	50 f7	60 M7	A58x53	60 M7	32	8
<b>045</b>	MR	M10	20	8	38	68	8	13	10	58	60 f7	B58x53 c9	50 f7	60 M7	A58x53	60 M7	32	8
<b>046</b>	MN	M10	20	8	50	80	8	16	7	73	60 f7	B58x53 c9	50 f7	60 M7	A58x53	60 M7	32	7
<b>065-067</b>	MR	M10	20	10	50	90	10.5	21	10	80	72 f7	B70x64 c9	62 f7	72 M7	A70x64	72 M7	40	10
<b>090-091</b>	MN-MR	M10	25	10	50	90	10.5	22	10	80	85 f7	B80x74 c9	70 f7	80 M7	A80x74	85 M7	45	10
<b>150-155</b>	MN	M10	25	10	50	90	10.5	22	10	80	85 f7	B80x74 c9	70 h7	80 M7	A80x74	85 M7	45	10
	MR	M14	30	12	65	110	12	22	15	98	105 f7	B100x94 c9	85 h7	105 M7	A100x94	105 M7	52	12
<b>250-255</b>	MN	M14	25	12	65	110	12	22	15	97	105 f7	B100x94 c9	85 f7	105 M7	A100x94	105 M7	52	13

# MN1

Flangia e albero cilindrico  
Sortie à arbre claveté

Mounting flange and keyed cylindrical shaft  
Brida y eje cilíndrico

Flansch und Passfederwelle  
Flange e eixo cilíndrico

# MR1

Flangia e albero cilindrico rinforzato  
Sortie renforcée à arbre claveté

Mounting flange and heavy duty keyed cylindrical shaft  
Brida y eje cilíndrico reforzado

Flansch und verstärkt Passfeder-Welle  
Flange e eixo cilíndrico reforçado

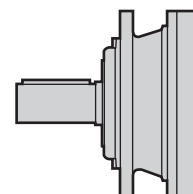
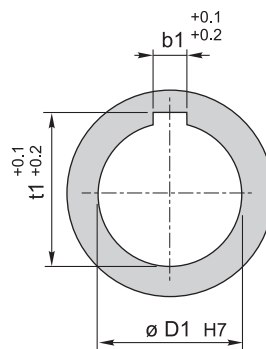
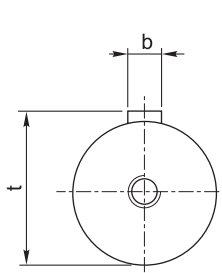
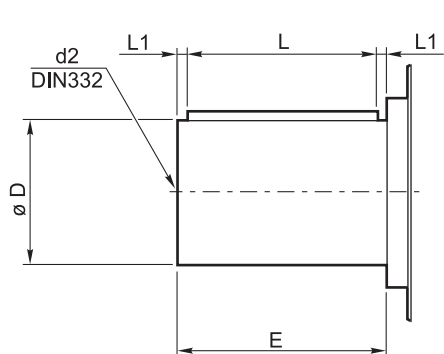

010 - 155

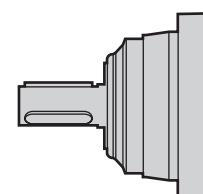
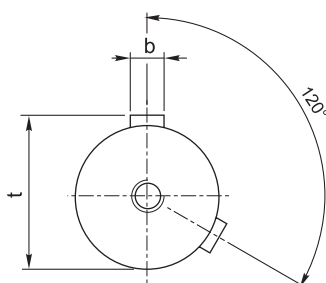
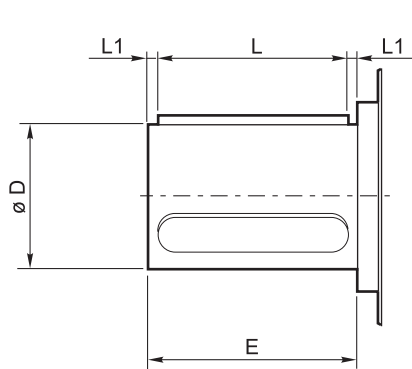

250-255

		D	E	L	L1	t	b	d2	D1	t1	b1
<b>010</b>	MN1-MR1	42 k6	82	70	6	45	12	M16	42	45	12
<b>020</b>	MR1	65 m6	105	90	7.5	69	18	M20	65	69	18
<b>030</b>	MR1	65 m6	105	90	7.5	69	18	M20	65	69	18
<b>040</b>	MN1	65 m6	105	90	7.5	69	18	M20	65	69	18
<b>045</b>	MR1	65 m6	105	90	7.5	69	18	M20	65	69	18
<b>046</b>	MN1	65 m6	105	90	7.5	69	18	M20	65	69	18
<b>065-067</b>	MR1	80 m6	130	110	10	85	22	M20	80	85	22
<b>090-091</b>	MN1-MR1	90 m6	170	160	5	95	25	M24	90	95	25
<b>150-155</b>	MN1	100 m6	210	200	5	106	28	M24	100	106	28
	MR1	100 m6	210	200	5	106	28	M24	100	106	28
<b>250-255</b>	MN1	110 m6	210	200	5	116	28	M24	100	116	28



# FP

Albero cavo con cava per linguetta  
Arbres creux avec clavette

Hollow-shaft with keyway  
Ejes huecos con chavetero

Hohlwellen mit Passfedernut  
Eixos ocos com chavetera

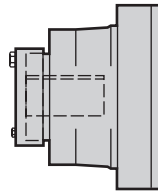

020 - 255

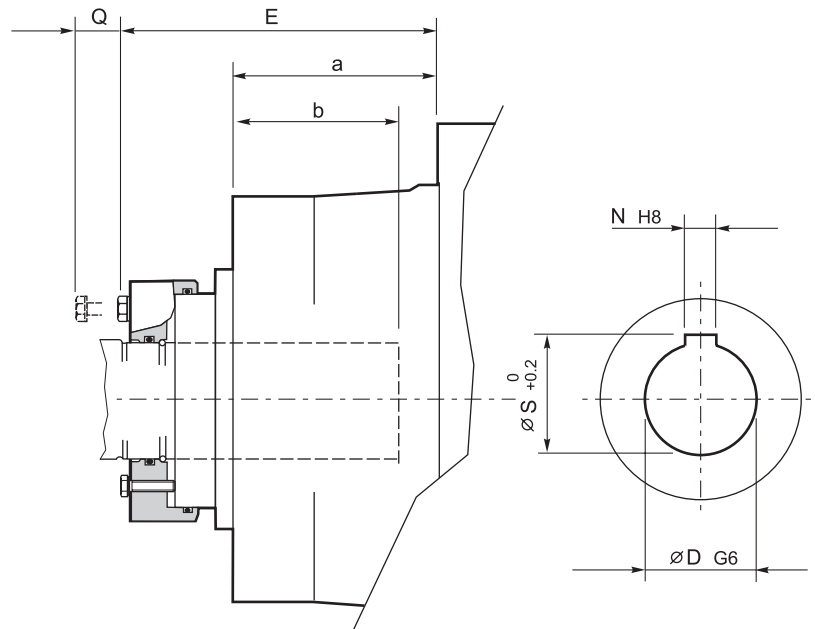
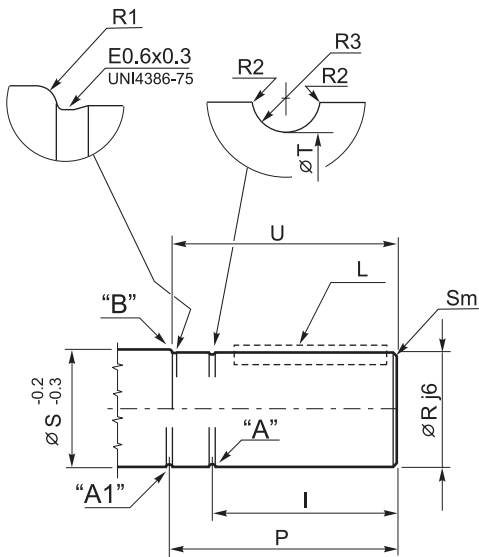

"A" gola obbligatoria per bloccaggio  
"A1" o "B" gole in alternativa per estrazione

"A" Obligatory locking groove  
"A1" or "B" alternative extraction groove

"A" Zwangsrille für Blockierung  
"A1" oder "B" alternative Rillen für das Herausziehen

"A" gorge obligatoire pour blocage  
"A1" ou "B" gorges comme alternative pour extraction

"A" ranura obligatoria para bloqueo / Obligatory locking groove  
"A1" o "B" ranuras en alternativa para extracción

"A" sulco obrigatório para o bloqueio  
"A1" ou "B" sulcos alternativos para a extracção

	D	M	N	R	R1	R2	R3	S	T	I	P	L	U	E	Q	a	b	Sm
<b>020</b>	50	53.8	14	50	1.4	0.4	1.8	53	47.5	92.5	119.5	14x9x70	118	130	60	105	90	1.5-2
<b>030</b>	65	69.4	18	65	1.4	0.4	1.8	68	63.8	102.5	139.5	18x11x90	130	140	70	110	100	1.5-2
<b>045</b>	65	69.4	18	65	1.4	0.4	1.8	68	63.8	102.5	139.5	18x11x90	130	140	70	110	100	1.5-2
<b>065-067</b>	80	85.4	22	80	1.6	0.4	1.8	83	76.8	138	162.5	22x14x110	161	170	70	137	130	2
<b>090-091</b>	90	95.4	25	90	1.6	0.4	1.8	93	86.8	158	183.5	25x14x125	182	193	70	157.5	150	2
<b>150-155</b>	100	106.4	28	100	1.6	0.4	1.8	103	98.8	180	206	28x11x140	204	235	80	197	170	2
<b>250-255</b>	110	116.4	28	110	3	0.6	3.4	116	104	159	186	28x16x125	183	253	80	212	150	2



## 9. SUPPORTI MASCHIO IN ENTRATA

Gli alberi di entrata descritti di seguito sono utilizzati quando il motore di azionamento, generalmente elettrico, è collegato all'albero di entrata mediante giunto elastico, o puleggia e cinghie.

La normale posizione di montaggio è con l'asse orizzontale; per altre posizioni di montaggio, occorre regolare la lubrificazione. Si prega di consultare il Servizio Tecnico Brevini per maggiori dettagli. La velocità massima di lavoro è generalmente 1800 min<sup>-1</sup>.

## 9. INPUT MALE SHAFTS

Input shafts described below are used when the driving motor, which is usually electric, is connected to the input shaft by flexible coupling or belts and pulleys.

Normal mounting position is with horizontal axis; for different positions the lubrication solution must be adjusted: please consult Brevini technical staff for more details. Max working speed is generally 1800 min<sup>-1</sup>.

## 9. ANTRIEBSWELLENSTÜMPFE

Die im Folgenden beschriebenen Antriebswellen werden eingesetzt, wenn der normalerweise elektrische Antriebsmotor mittels einer elastische Kupplung oder mithilfe von Riemenscheiben und Riemen angeschlossen wird.

Die normale Einbaulage ist horizontal; für andere Einbaupositionen muss die Schmierung eingestellt werden. Wenden Sie sich für weitere Einzelheiten an den Technischen Kundendienst Brevini. Die maximale Betriebsdrehzahl beträgt meist 1800 min<sup>-1</sup>.

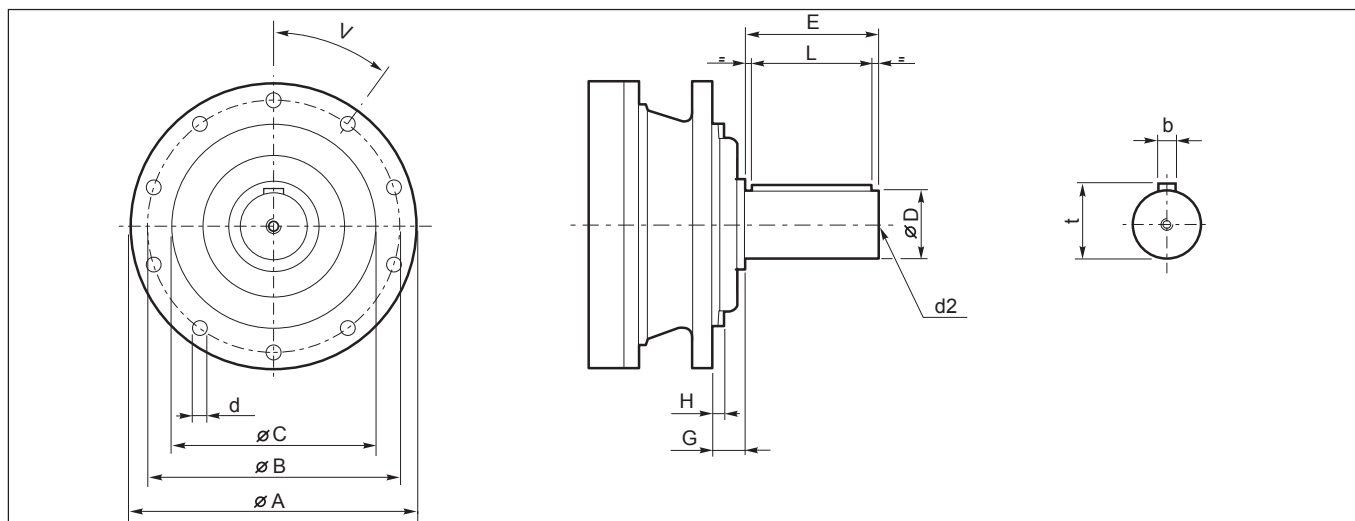

	A	B	C f7	D m6	E	G	H	I	L	b	d	d2 DIN332	t
S-45CR1	220	195	150	65	105	15	5	16	90	18	14	M20x42	69
S-46C1	272	245	175	65	105	39	10	18	90	18	14	M20x42	69
S-65CR1	280	250	200	80	130	40	20	20	110	22	16	M20x42	85
S-90CR1	325	295	230	90	170	36	5	25	160	25	18	M24x50	95

## 9. PALIER MALES EN ENTREE

Les arbres d'entrée décrits ci-après sont utilisés lorsque le moteur d'entraînement, généralement électrique, est relié à l'arbre d'entrée par un accouplement élastique ou poulie et courroie.

La position normale de montage est avec l'axe horizontal; pour les autres positions de montage, il faut régler la lubrification. Il est conseillé de s'adresser au Service technique Brevini pour de plus amples informations.

La vitesse maximale de fonctionnement est généralement de 1800 min<sup>-1</sup>.

## 9. SOPORTES MACHO EN LA ENTRADA

Los ejes de entrada que se describen a continuación se utilizan cuando el motor de accionamiento (generalmente eléctrico) está conectado el eje de entrada por medio de un acoplamiento elástico o de una polea y correas.

En la posición de montaje normal el eje es horizontal; en las demás posiciones es preciso ajustar la lubricación. Se aconseja contactar con el Servicio Técnico de Brevini. La velocidad máxima de trabajo suele cercarse a 1800 min<sup>-1</sup>.

## 9. SUPORTES MACHO NA ENTRADA

Os eixos de entrada descritos a seguir são utilizados quando o motor de acionamento, geralmente elétrico, é conectado ao eixo de entrada através de uma junta elástica ou polia e correia.

A posição de montagem normal é com o eixo horizontal; para outras posições de montagem é necessário regular a lubrificação. Consulte o Serviço Técnico da Brevini para obter mais detalhes. A velocidade máxima de serviço é geralmente de 1800 min<sup>-1</sup>.

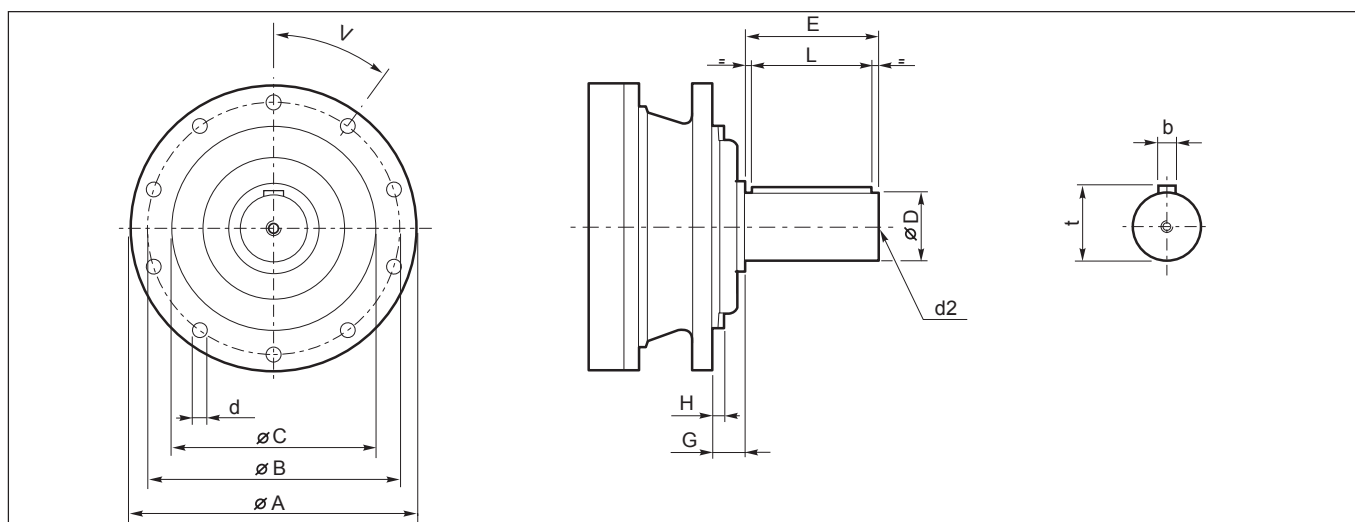

	A	B	C f7	D m6	E	G	H	I	L	b	d	d2 DIN332	t
S-45CR1	220	195	150	65	105	15	5	16	90	18	14	M20x42	69
S-46C1	272	245	175	65	105	39	10	18	90	18	14	M20x42	69
S-65CR1	280	250	200	80	130	40	20	20	110	22	16	M20x42	85
S-90CR1	325	295	230	90	170	36	5	25	160	25	18	M24x50	95

**Supporti maschio per entrata universale**

I tipi SU sono generalmente utilizzati con un giunto elastico, possono essere montati direttamente su qualsiasi tipo di riduttore con entrata universale 00 e possono essere forniti separatamente. Vedere la sezione relativa ai riduttori per dimensioni e carichi radiali.

**Male shafts for universal input**

These types generally used in combination with a flexible coupling. They fit directly onto any type of gear unit with universal input type 00 and can be supplied separately. See gearbox sections for dimensions and radial loads.

**Wellenstümpfe für Universalantriebe**

Die Typen der Baureihe SU werden gewöhnlich mit einer elastischen Kupplung verwendet, können direkt auf jede Getriebeart mit Universalantrieb 00 montiert werden und sind separat lieferbar. Für Abmessungen und Radiallasten siehe Abschnitt Getriebe.

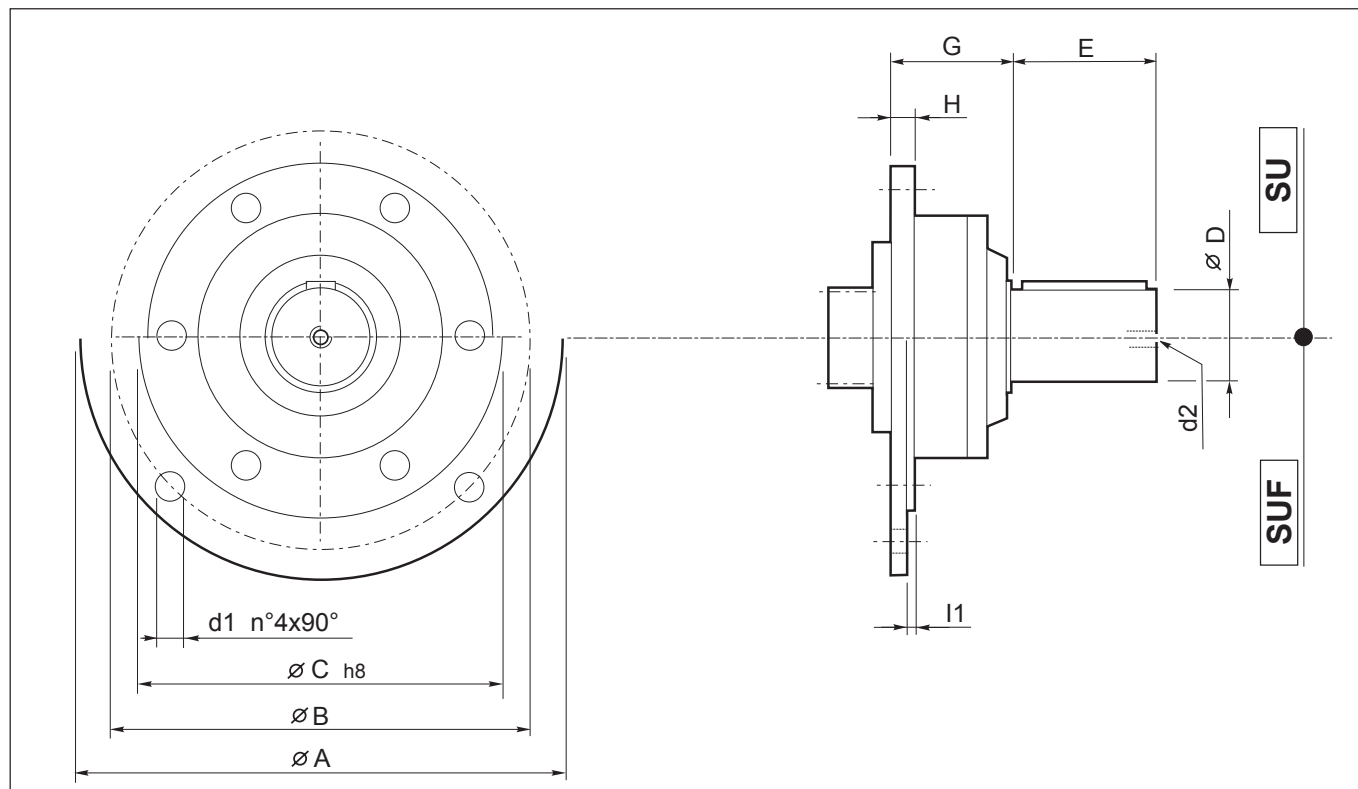

	A	B	C	D	d1	d2	E	G	H	l1	Codice / Code
SU1	—	—	—	28	—	M10x22	50	60	12	—	C1129800420
SU2	—	—	—	40	—	M10x22	58	60	12	—	C1129800380
SU3	—	—	—	48	—	M10x25	82	60	12	—	C1129800910
SUF1	250	215	180	28	13	M10x22	50	60	12	3	C1131900420
SUF2	250	215	180	40	13	M10x22	58	60	12	3	C1131900380
SUF3	250	215	180	48	13	M10x25	82	60	12	3	C1131900910

**Palier mâle pour prédisposition d'entrée universelle**

Les types SU sont généralement utilisés avec un accouplement élastique, peuvent être directement montés sur n'importe quel type de réducteur avec arbre d'entrée universel 00 et peuvent être livrés séparément. Voir section relative aux réducteurs pour les dimensions et les charges radiales.

**Soportes macho para entrada universal**

Los del tipo SU se utilizan generalmente con un empalme elástico y se montan en cualquier reductor con entrada universal 00. Pueden solicitarse por separado. Las dimensiones y las cargas radiales pueden verse en la sección dedicada a los reductores.

**Suportes macho para entrada universal**

Os tipos SU são geralmente utilizados com uma junta elástica, podem ser montados diretamente em qualquer tipo de redutor com entrada universal 00 e podem ser fornecidos separadamente. Consulte a seção relativa aos redutores para obter as dimensões e as cargas radiais.

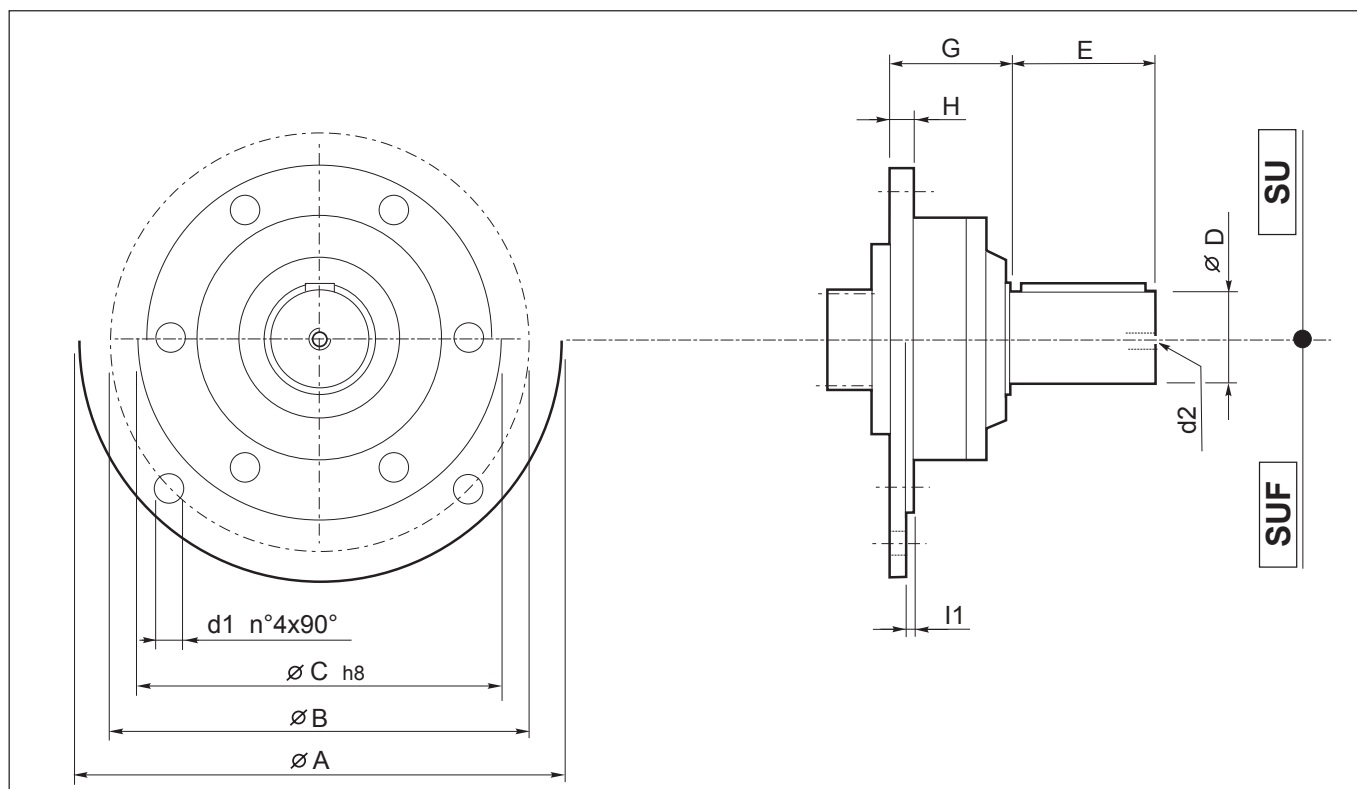

	A	B	C	D	d1	d2	E	G	H	l1	Codice / Code
SU1	—	—	—	28	—	M10x22	50	60	12	—	C1129800420
SU2	—	—	—	40	—	M10x22	58	60	12	—	C1129800380
SU3	—	—	—	48	—	M10x25	82	60	12	—	C1129800910
SUF1	250	215	180	28	13	M10x22	50	60	12	3	C1131900420
SUF2	250	215	180	40	13	M10x22	58	60	12	3	C1131900380
SUF3	250	215	180	48	13	M10x25	82	60	12	3	C1131900910

## 10. FRENI LAMELLARI A BAGNO D'OLIO

I riduttori di questo catalogo possono essere dotati in entrata di freno a dischi multipli a bagno d'olio ad apertura idraulica.

### Freni negativi

Questi freni agiscono sotto la spinta di una serie di molle su coppie di dischi alternati fissi e mobili; lo sbloccaggio avviene per effetto della pressione idraulica nel pistone. Hanno quindi un funzionamento "negativo"; sono da impiegare come freni di stazionamento, non per frenatura dinamica. Tali prestazioni, con margine di accuratezza +/- 10%, sono sempre calcolate con contropressione 0; in caso contrario la coppia frenante viene percentualmente ridotta nel rapporto contropressione/pressione min. apertura. Per la selezione, occorre tenere conto di due condizioni:

1) Coppia freno  $\times i_{\text{eff}} >$  Coppia richiesta in uscita;

2) Coppia freno  $\times i_{\text{eff}} < 1.1 T_{2\text{max}}$

Ricordiamo che le alte velocità di rotazione, oppure prolungati funzionamenti con asse verticale, possono generare elevati aumenti di temperatura: in questi casi, contattare il Servizio Tecnico Commerciale BREVINI per opportuni consigli in merito. Per la lubrificazione, si consigliano oli minerali resistenti al calore ed all'invecchiamento, di viscosità ISO VG 32, indice di viscosità pari o superiore a 95. Gli oli idraulici sono generalmente idonei; nel capitolo relativo alla lubrificazione sono riportati quelli consigliati.

## 10. MULTIDISC BRAKES IN OIL

The gear units in this catalogue can be supplied with multidisc brakes, in oil, hydraulically released.

### Negative brakes

These brakes are actuated by a series of coil springs pressing together alternate fixed and rotating discs. The braking torque is released by mean of an hydraulic pressure supplied from outside. This means that they work as "negative" brakes and are intended for safety or parking only, when the input shaft is not rotating. These performances, with +/- 10% accuracy margins, are always calculated without back pressure; otherwise the braking torque is reduced as a percentage of the ratio back pressure/minimum opening pressure. When carrying out the selection, the following two conditions must be taken into account:

1) Braking torque  $\times i_{\text{eff}} >$  required output torque;

2) Braking torque  $\times i_{\text{eff}} < 1.1 T_{2\text{max}}$

We remind you that high rotation speed, or extended running with vertical axis, can generate considerable temperature increases; in such cases please apply to BREVINI technical staff for advice. For lubrication we recommend to use mineral oils heat and aging resistant, having viscosity ISO VG 32 and viscosity index at least 95; hydraulic oils are usually suitable (for recommended types see lubrication chapter).

## 10. LAMELLENBREMSEN IM ÖLBAD

Die Getriebe des vorliegenden Katalogs können mit im Ölbad laufenden Lamellenbremsen mit hydraulischer Spreizung ausgestattet werden.

### Negative Bremsen

Die Bremsen wirken unter dem Druck einer Reihe von Federn auf abwechselnd fixe und bewegliche Scheibenpaare; das Lösen der Bremse erfolgt durch den hydraulischen Druck im Kolben. Sie haben demnach eine "negative" Funktion; sie werden als Feststellbremsen benutzt und dienen nicht zum dynamischen Abbremsen. Diese Leistungen werden bei einer Genauigkeitsmarge von +/- 10% mit einem Gegendruck von 0 berechnet; anderenfalls wird das Bremsmoment prozentual im Verhältnis Gegendruck/Mindestöffnungsdruck reduziert. Bei der Auswahl sind zwei Bedingungen zu berücksichtigen:

1) Bremsmoment  $\times i_{\text{eff}} >$  erforderliches Abtriebsdrehmoment;

2) Bremsmoment  $\times i_{\text{eff}} < 1.1 T_{2\text{max}}$

Es wird daran erinnert, dass hohe Drehzahlen oder lange Betriebszeiten mit vertikaler Achse zu starken Temperaturerhöhungen führen können: Wenden Sie sich in diesem Fall an den technischen Kundendienst BREVINI, der Sie diesbezüglich gerne berät. Zur Schmierung sollten wärme- und alterungsbeständige Mineralöle mit Viskosität ISO VG 32 verwendet werden (Viskositätsindex gleich oder höher als 95). Die Hydrauliköle sind normalerweise geeignet; im Kapitel "Schmierung" werden die empfohlenen Ölsorten aufgeführt.

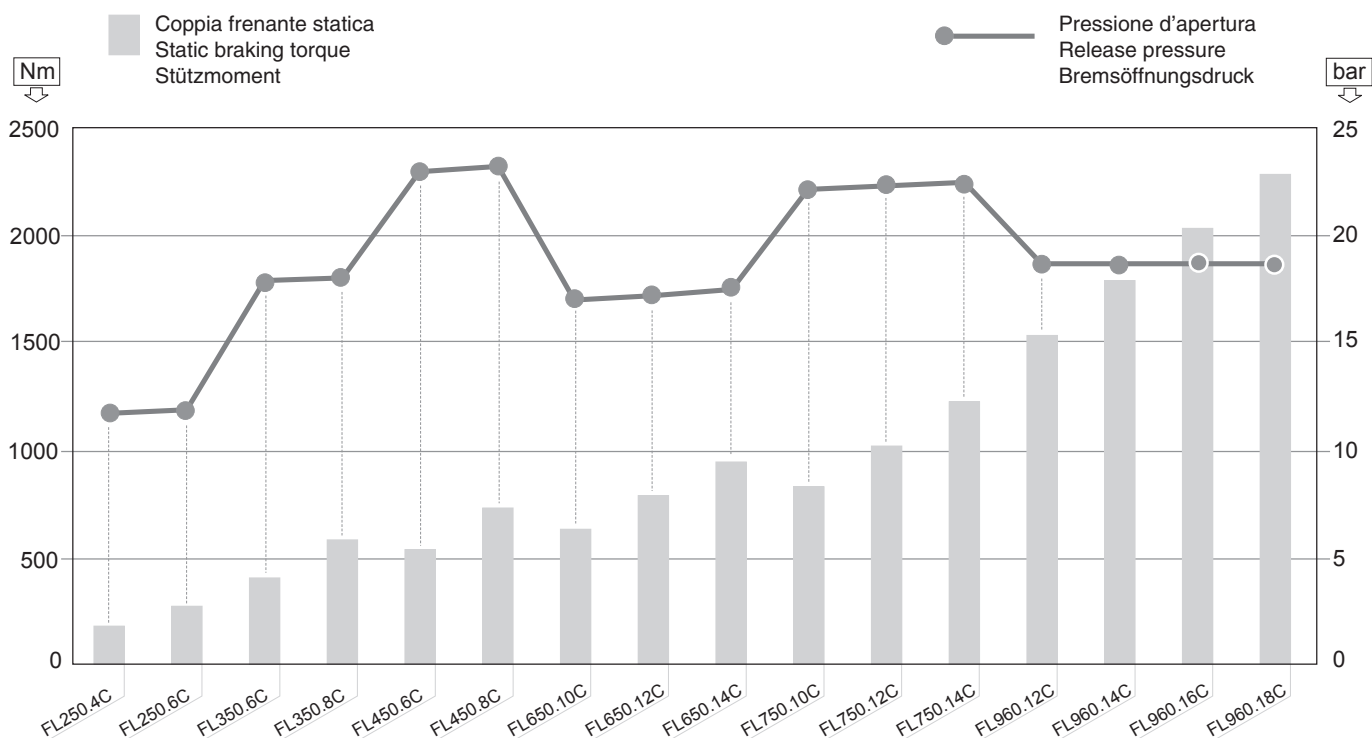

## 10.FREINS A LAMELLES IMMERGEES

Les réducteurs de ce catalogue peuvent être dotés en entrée d'un frein à lamelles immergées à commande hydraulique.

### Freins négatifs

Ces freins agissent sous la poussée d'une série de ressorts sur des paires de disques alternés fixes et mobiles; le déblocage s'effectue par l'action de la pression hydraulique dans le piston. Ils ont donc un fonctionnement "négatif"; ils doivent être utilisés comme frein de stationnement et non pas pour le freinage dynamique. Ces performances, avec un marge de +/- 10%, sont toujours calculées en tenant compte d'une contre-pression 0; dans le cas contraire, le couple de freinage est proportionnellement réduit dans le rapport contre-pression/pression mini d'ouverture. Pour la sélection, il faut tenir compte de deux conditions:

1) Couple de freinage  $\times i_{\text{eff}} >$  Couple requis en sortie;

2) Couple de freinage  $\times i_{\text{eff}} < 1.1 T_{2\text{max}}$

Noter que les vitesses de rotation élevées, ainsi que le fonctionnement prolongé avec l'axe vertical, peuvent entraîner des élévations de température: dans ces cas, appeler le Service tecnico-commercial BREVINI pour des conseils utiles à ce propos. Pour la lubrification, nous conseillons des huiles minérales résistantes à la chaleur et au vieillissement, ayant une viscosité ISO VG 32. indice de viscosité égal ou supérieur à 95. Les huiles hydrauliques conviennent généralement; dans le chapitre consacré à la lubrification sont indiqués les lubrifiants préconisés.

## 10.FRENOS LAMINARES EN BAÑO DE ACEITE

En la entrada de los reductores de este catálogo se pueden montar discos múltiples en baño de aceite con apertura hidráulica.

### Frenos negativos

Estos frenos son accionados por una serie de muelles que comprimen pares de discos fijos y móviles alternados; el desbloqueo se produce por efecto de la presión hidráulica sobre el pistón. Por ello se habla de funcionamiento "negativo"; se emplean como frenos de estacionamiento, no para el frenado dinámico. El intervalo de tolerancia es de +/- 10% y se calcula siempre con contrapresión 0; de lo contrario el par de frenado de la relación contrapresión/presión mín de apertura se reduce. Antes de la selección hay que tomar en cuenta dos factores:

1) Par freno  $\times i_{\text{ef}} >$  Par de salida necesario;

2) Par freno  $\times i_{\text{ef}} < 1.1 T_{2\text{max}}$

Si el reductor trabaja demasiado tiempo en posición vertical o con velocidades grandes puede registrarse un aumento significativo de la temperatura: se aconseja contactar con el Servicio Técnico de Brevini.

Lubricar con aceites minerales resistentes al calor y al envejecimiento con viscosidad ISO VG 32 y un índice de viscosidad igual o mayor que 95.

En general los aceites hidráulicos tienen un comportamiento adecuado; los tipos recomendados se enumeran en el capítulo de lubricación.

## 10.FREIOS LAMELARES A BANHO DE ÓLEO

Os redutores deste catálogo podem ser dotados, na entrada, de freio a discos múltiplos a banho de óleo com abertura hidráulica.

### Freios negativos

Esses freios agem sob a pressão de uma série de molas em pares de discos alternados, fixos e móveis; o desbloqueio ocorre por efeito da pressão hidráulica no pistão. Têm, portanto, um funcionamento "negativo"; devem ser empregados como freios de estacionamento, não para frenagem dinâmica. Tais desempenhos, com margem de precisão de +/- 10% são sempre calculados com contrapressão 0, caso contrário o torque de frenagem é percentualmente reduzido na relação contrapressão/pressão mín. de abertura. Para a seleção, é necessário levar em consideração duas condições:

1) Torque do freio  $\times i_{\text{eff}} >$  Torque necessário na saída;

2) Torque do freio  $\times i_{\text{eff}} < 1.1 T_{2\text{max}}$

Recordamos que as altas velocidades de rotação ou períodos de funcionamento prolongados com eixo vertical podem gerar grandes aumentos de temperatura: nesses casos, entre em contato com o Serviço Técnico Comercial da BREVINI para obter conselhos adequados a respeito.

Para a lubrificação, são aconselháveis óleos minerais resistentes ao calor e ao envelhecimento, com viscosidade ISO VG 32. índice de viscosidade igual ou superior a 95. Os óleos hidráulicos em geral são adequados; no capítulo relativo à lubrificação são indicados aqueles aconselhados.

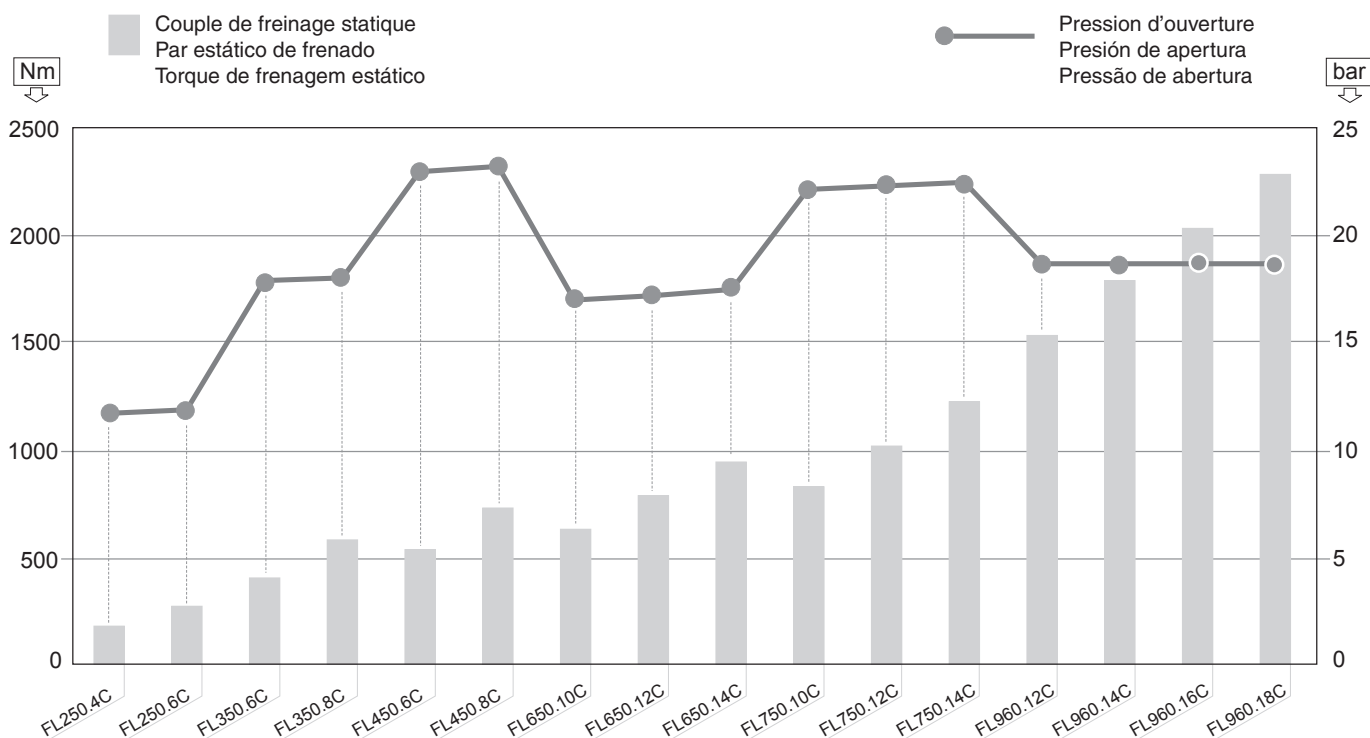



	T [Nm]	P [bar]	Pmax [bar]	Vo [l]		Va [cm <sup>3</sup> ]	
				orizzontale horizontal	verticale vertical	lamelle nuove new discs Neue Lamellen	
<b>FL250</b> FL 250.4C	181	13.28	315	0.3	0.6	15	
	FL 250.6C	278	13.28	315	0.3	0.6	15
<b>FL350</b> FL 350.6C	417	19.92	315	0.3	0.6	15	
	FL 350.8C	571	19.92	315	0.3	0.6	15
<b>FL450</b> FL 450.6C	540	25.59	315	0.3	0.6	15	
	FL 450.8C	737	25.59	315	0.3	0.6	15
<b>FL650</b> FL 650.10C	642	19.92	315	0.5	1.0	15	
	FL 650.12C	792	19.92	0.5	1.0	15	
	FL 650.14C	949	19.92	315	0.5	1.0	15
<b>FL750</b> FL 750.10C	834	25.59	315	0.5	1.0	15	
	FL 750.12C	1027	25.59	315	0.0	1.0	15
	FL 750.14C	1229	25.59	315	0.5	1.0	15
<b>FL960</b> FL 960.12C	1528	21.98	315	1.2	2.4	22	
	FL 960.14C	1783	21.98	315	1.2	2.4	22
	FL 960.16C	2038	21.98	315	1.2	2.4	22
	FL 960.18C	2293	21.98	315	1.2	2.4	22

**T:** Coppia statica media / Medium static torque / Mittleres Stützmoment  
**P:** Pressione apertura freno / Brake release pressure / Bremsöffnungsdruck  
**Pmax:** Pressione max. / Max pressure / Höchstdruck  
**Vo:** Volume olio / Oil quantity / Ölmenge  
**Va:** Volume olio per comando apertura freno / Oil quantity for brake release control / Bremsölmenge zum Lösen der Bremse

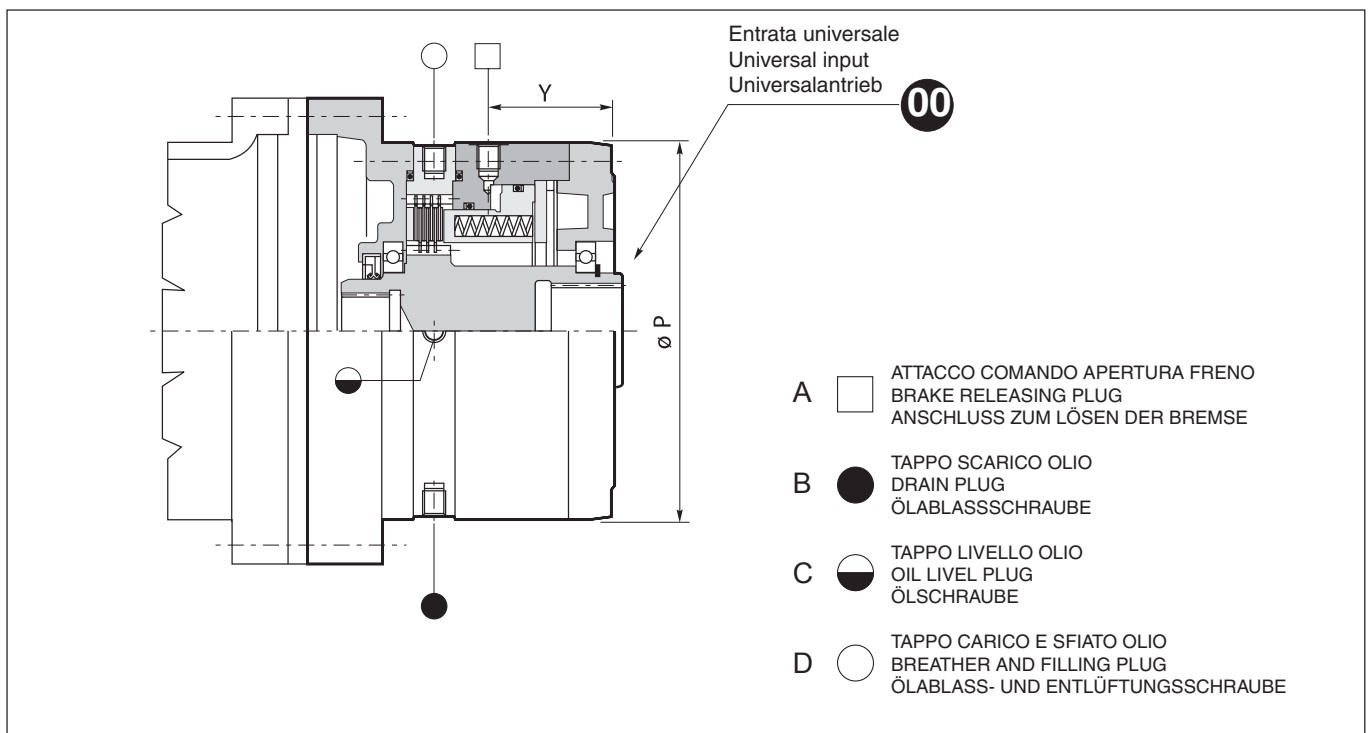

	P	Y	ATTACCHI / PLUGS / ANSCHLÜSSE				Kg
			A	B	C	D	
<b>FL 250</b>	195	67	M12X1.5	R 1/4"	R 1/4"	R 1/4"	24
<b>FL 350</b>	195	67	M12X1.5	R 1/4"	R 1/4"	R 1/4"	24
<b>FL 450</b>	195	67	M12X1.5	R 1/4"	R 1/4"	R 1/4"	26
<b>FL 650</b>	195	67	M12X1.5	R 1/4"	R 1/4"	R 1/4"	36
<b>FL 750</b>	225	72.5	M12X1.5	R 1/4"	R 1/4"	R 1/4"	37
<b>FL 960</b>	225	72.5	M12X1.5	R 1/4"	R 1/4"	R 1/4"	42

	T [Nm]	P [bar]	Pmax [bar]	Vo [l]		Va [cm <sup>3</sup> ] lamelles neuves laminillas nuevas discos novos	
				horizontal horizontal	vertical vertical		
<b>FL250</b>	FL 250.4C	181	13.28	315	0.3	0.6	15
	FL 250.6C	278	13.28	315	0.3	0.6	15
<b>FL350</b>	FL 350.6C	417	19.92	315	0.3	0.6	15
	FL 350.8C	571	19.92	315	0.3	0.6	15
<b>FL450</b>	FL 450.6C	540	25.59	315	0.3	0.6	15
	FL 450.8C	737	25.59	315	0.3	0.6	15
<b>FL650</b>	FL 650.10C	642	19.92	315	0.5	1.0	15
	FL 650.12C	792	19.92	315	0.5	1.0	15
	FL 650.14C	949	19.92	315	0.5	1.0	15
<b>FL750</b>	FL 750.10C	834	25.59	315	0.5	1.0	15
	FL 750.12C	1027	25.59	315	0.0	1.0	15
	FL 750.14C	1229	25.59	315	0.5	1.0	15
<b>FL960</b>	FL 960.12C	1528	21.98	315	1.2	2.4	22
	FL 960.14C	1783	21.98	315	1.2	2.4	22
	FL 960.16C	2038	21.98	315	1.2	2.4	22
	FL 960.18C	2293	21.98	315	1.2	2.4	22

**T:** Couple statique moyen / Par estático medio / Tração estática média  
**P:** Pression d'ouverture du frein / Presión de apertura del freno / Pressão de abertura do freio  
**Pmax:** Pression max. / Presión máx. / Pressão máx.  
**Vo:** Volume d'huile / Volumen de aceite / Volume de óleo  
**Va:** Volume d'huile pour commande d'ouverture du frein / Volumen de aceite para el mando de apertura del freno / Volume de óleo para o comando da abertura do freio

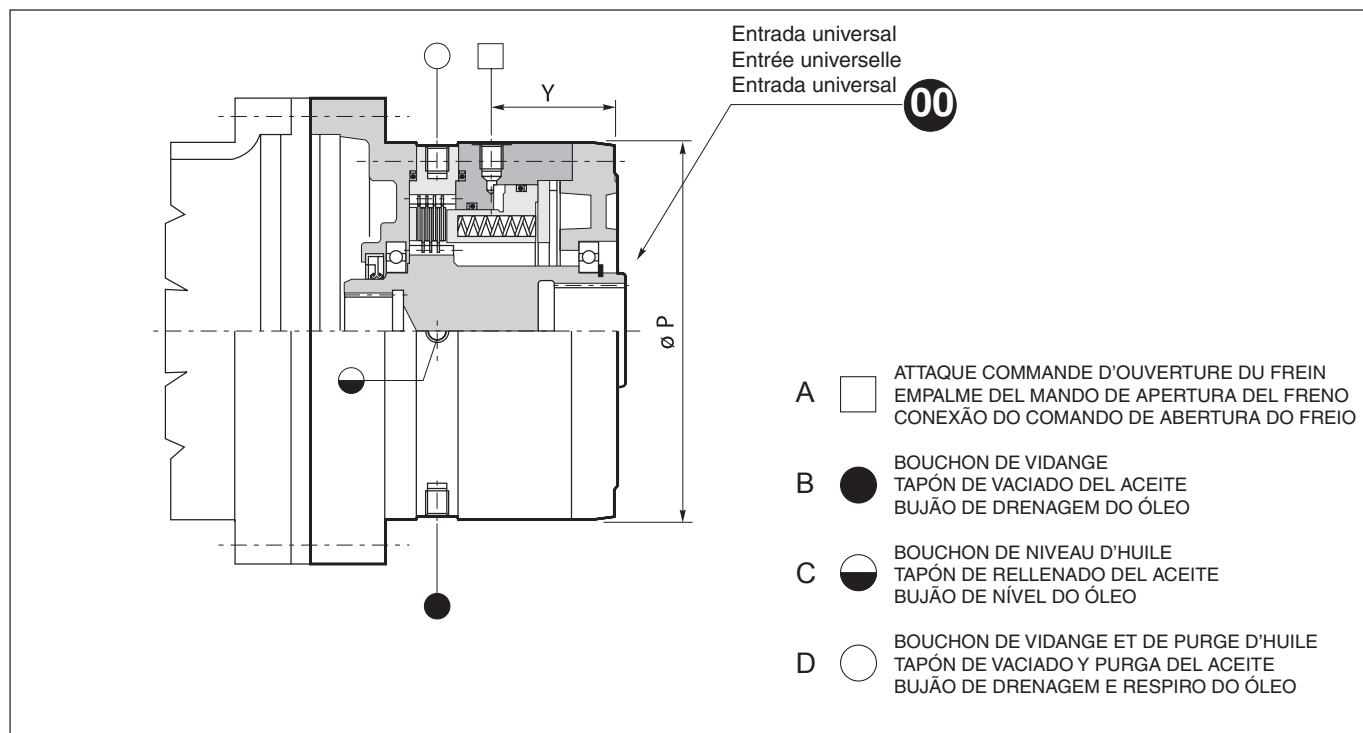

	P	Y	FIXATIONS / EMPALMES / ENGATES				Kg
			A	B	C	D	
<b>FL 250</b>	195	67	M12X1.5	R 1/4"	R 1/4"	R 1/4"	24
<b>FL 350</b>	195	67	M12X1.5	R 1/4"	R 1/4"	R 1/4"	24
<b>FL 450</b>	195	67	M12X1.5	R 1/4"	R 1/4"	R 1/4"	26
<b>FL 650</b>	195	67	M12X1.5	R 1/4"	R 1/4"	R 1/4"	36
<b>FL 750</b>	225	72.5	M12X1.5	R 1/4"	R 1/4"	R 1/4"	37
<b>FL 960</b>	225	72.5	M12X1.5	R 1/4"	R 1/4"	R 1/4"	42

FRENI LAMELLARI UNIVERSALI

MULTIDISC BRAKES

UNIVERSAL  
LAMELLENBREMSEN

	T [Nm]	P [bar]	Pmax [bar]	Vo [l]		Va [cm <sup>3</sup> ]
				orizzontale horizontal horizontal	verticale vertical vertikal	lamelle nuove new discs Neue Lamellen
FL620.U	271	24.9	210	0.1	0.2	10
FL635.U	377	13.6	315	0.1	0.2	10

- T: Coppia statica media / Medium static torque / Mittleres Stützmoment  
P: Pressione apertura freno / Brake release pressure / Bremsöffnungsdruck  
Pmax: Pressione max. / Max pressure / Höchstdruck  
Vo: Volume olio / Oil quantity / Ölmenge  
Va: Volume olio per comando apertura freno / Oil quantity for brake release control / Bremsölmenge zum Lösen der Bremse

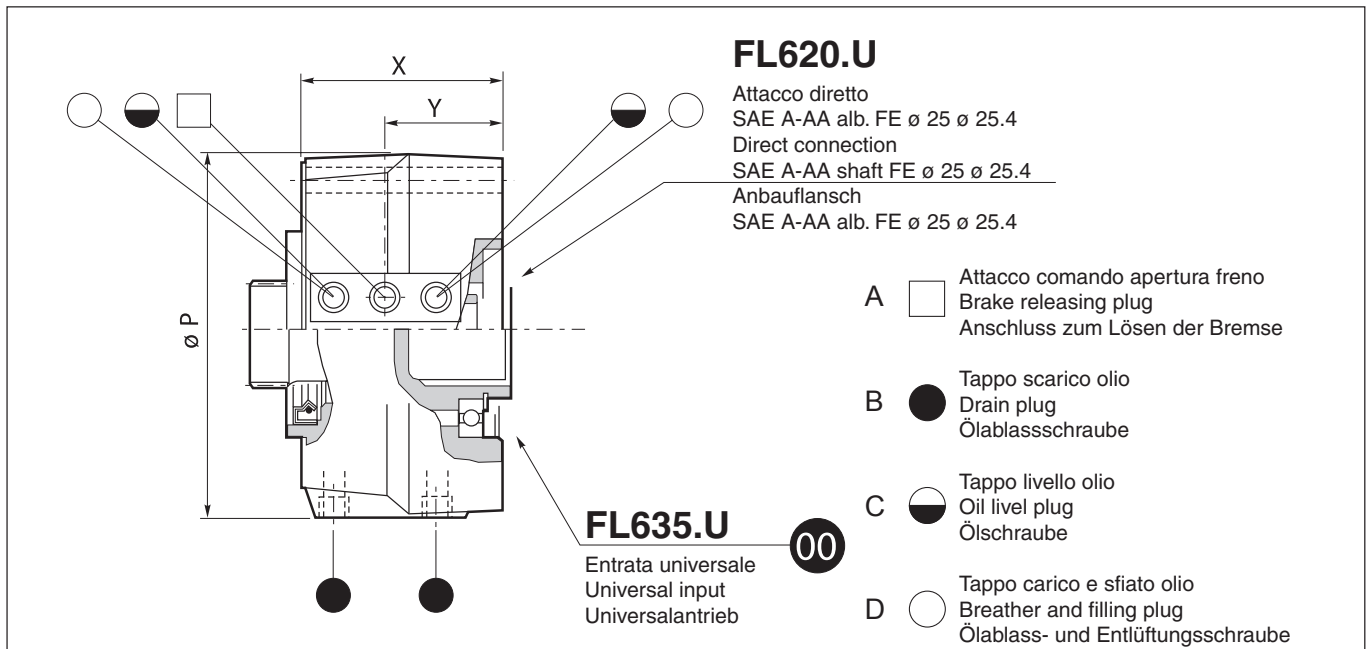

	P	X	Y	ATTACCHI / PLUGS / ANSCHLÜSSE				Kg	Codice / Code / Code
				A	B	C	D		
FL 620.U	161	104.5	46	M10x1	R 1/8"	R 1/8"	R 1/8"	8	C1103704120 (alb. FE ø 25) C1103704120 (alb. FE ø 25.4)
FL 635.U	165	91	59	M12x1.5	R 1/4"	R 1/4"	R 1/4"	9	C1109200160

**FREINS A LAMELLES  
UNIVERSELS**

**FRENOS LAMINARES  
UNIVERSALES**

**FREIOS LAMELARES  
UNIVERSAIS**

	T [Nm]	P [bar]	Pmax [bar]	Vo [l]		Va [cm³]
				horizontal horizontal horizontal	vertical vertical vertical	lamelles neuves laminillas nuevas discos novos
<b>FL620.U</b>	271	24.9	210	0.1	0.2	10
<b>FL635.U</b>	377	13.6	315	0.1	0.2	10

- T:** Couple statique moyen / Par estático medio / Tração estática média  
**P:** Pression d'ouverture du frein / Presión de apertura del freno / Pressão de abertura do freio  
**Pmax:** Pression max. / Presión máx. / Pressão máx.  
**Vo:** Volume d'huile / Volumen de aceite / Volume de óleo  
**Va:** Volume d'huile pour commande d'ouverture du frein / Volumen de aceite para el mando de apertura del freno / Volume de óleo para o comando da abertura do freio

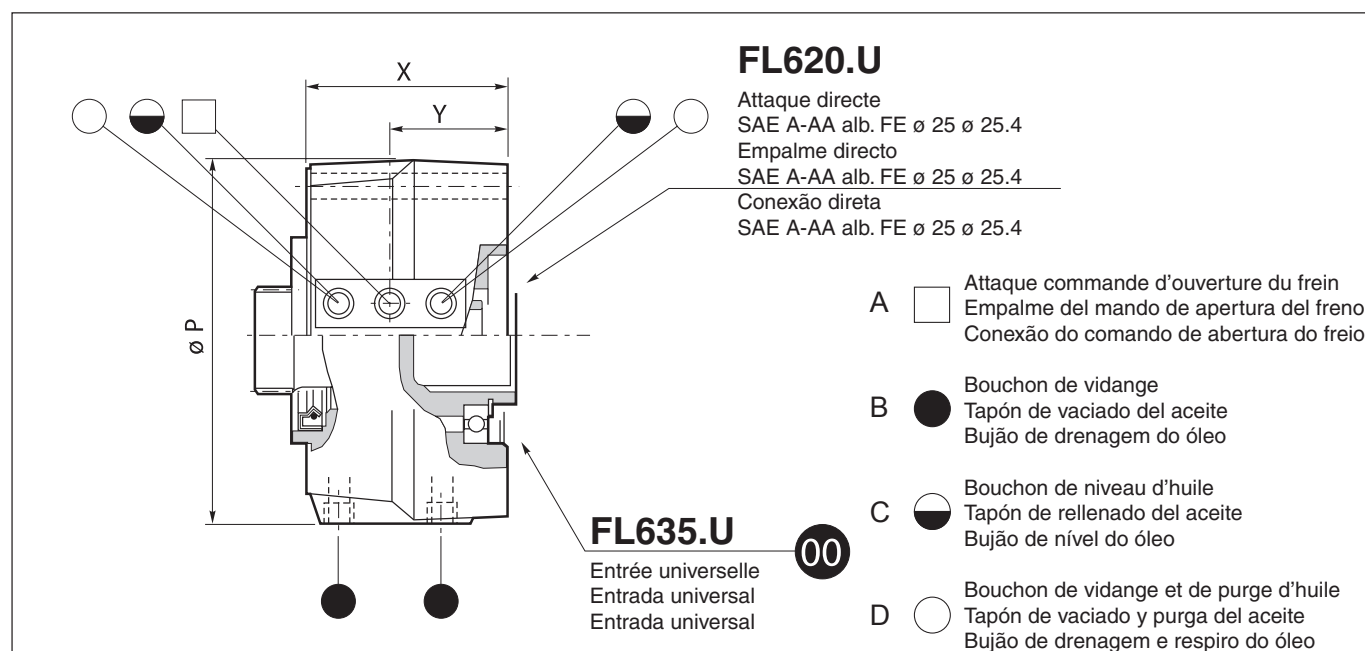

	P	X	Y	FIXATIONS / EMPALMES / ENGATES				Kg	Code / Código / Código
				A	B	C	D		
<b>FL 620.U</b>	161	104.5	46	M10x1	R 1/8"	R 1/8"	R 1/8"	8	C1103704120 (alb. FE ø 25) C1103704120 (alb. FE ø 25.4)
<b>FL 635.U</b>	165	91	59	M12x1.5	R 1/4"	R 1/4"	R 1/4"	9	C1109200160

## 11. ENTRATE UNIVERSALI

L'entrata universale è una configurazione che, montata in ingresso ai riduttori, permette di accoppiare le più diverse tipologie di motorizzazioni tramite una flangia e un manicotto di adattamento appositi.

Esistono due diverse dimensioni di entrata universale in funzione delle grandezze montate come stadio in ingresso sui riduttori.

Questa configurazione è possibile anche quando il riduttore sia dotato in entrata di freno lamellare.

L'applicabilità può essere dedotta dalle tavole dimensionali.

## 11. UNIVERSAL INPUTS

The universal input is a configuration mounted on the gear unit input, enabling the coupling of many types of motorizations by means of a special flange and adapter coupling.

Two different universal input sizes are available according to the sizes mounted as input stage on the gear units.

The universal input configuration can be used whether an external lamellar brake is fitted to the gearbox input.

Applicability can be obtained from the dimensional tables.

## 11. UNIVERSAL-ANTRIEBE

Der Universalantrieb ist eine Anordnung, die am Getriebeeingang montiert wird und die ermöglicht, die unterschiedlichsten Motortypen mithilfe eines Flansches oder einer Adapterhülse anzukoppeln.

Je nach der auf den Getrieben montierten Antriebsstufen stehen zwei verschiedene Größen des Universalantriebs zur Verfügung.

Konfiguration ist anwendbar, unabhängig davon, ob das Getriebe am Eingang mit einer Lamellenbremse ausgestattet ist.

Die Eignung kann den Maßbildern entnommen werden.

00

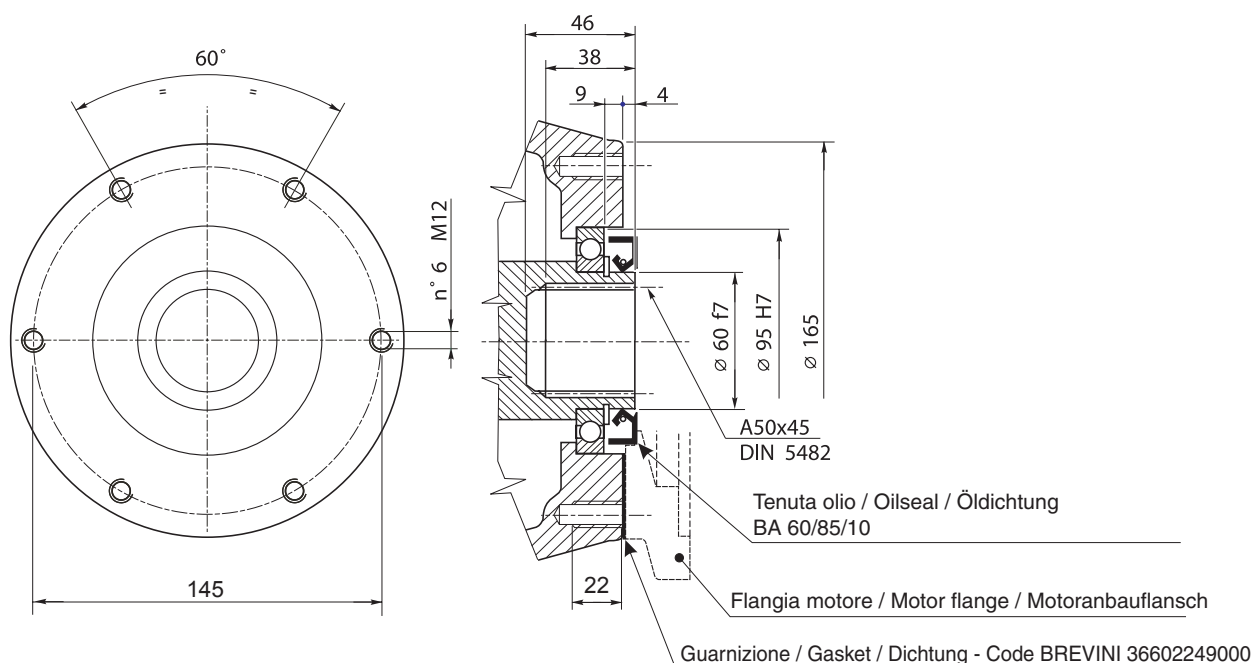

00

Per freno / For brake / Für brense

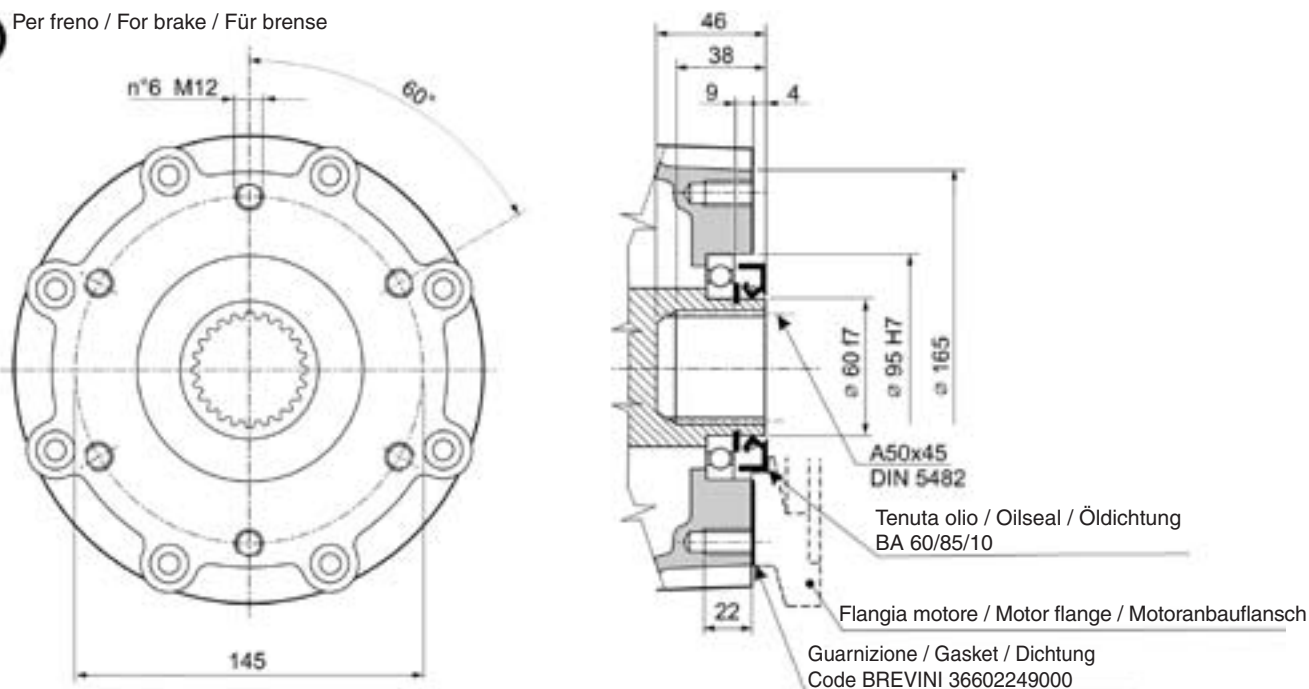

## 11. PREDISPOSITIONS D'ENTREE

La pr edisposition d'entr ee universelle est une configuration qui, mont ee en entr ee aux r educteurs, permet d'accoupler les diff erents types de moteurs par un flasque-bride et un manchon ou moyeu d'adaptation appropri es.

Il existe deux diff erentes dimensions de pr edispositions d'entr ee universelles en fonction des grandeurs mont ees comme  tage en entr ee, sur les r educteurs.

Cette configuration est possible  galement quand le r educteur est dot e d'une entr ee de frein lamellaire externe.

L'adaptabilit e peut  tre tir ee des planches des dimensions d'encombrement.

## 11. ENTRADAS UNIVERSALES

La entrada universal es una configuraci n que permite acoplar todo tipo de motores por medio de una brida y un manguito adaptador especiales.

Dependiendo del tama o elegido para la entrada del reductor puede haber dos medidas de entrada universal.

Se puede realizar independientemente de que en la entrada del reductor haya un freno laminar exterior.

Las posibilidades de aplicaci n se deducen de los dise os dimensionales.

## 11. ENTRADAS UNIVERSAIS

A entrada universal   uma configura o que, montada na entrada dos redutores, permite acoplar os mais diversos tipos de motores atrav s de um flange e uma luva de adapta o adequados.

Existem duas dimens es de entrada universal diferentes em fun o dos tamanhos montados como  stgio na entrada dos redutores.

Essa configura o   poss vel mesmo quando o redutor   dotado, na entrada, de freio lamelar externo.

A aplicabilidade pode ser deduzida atrav s das tabelas dimensionais.

00

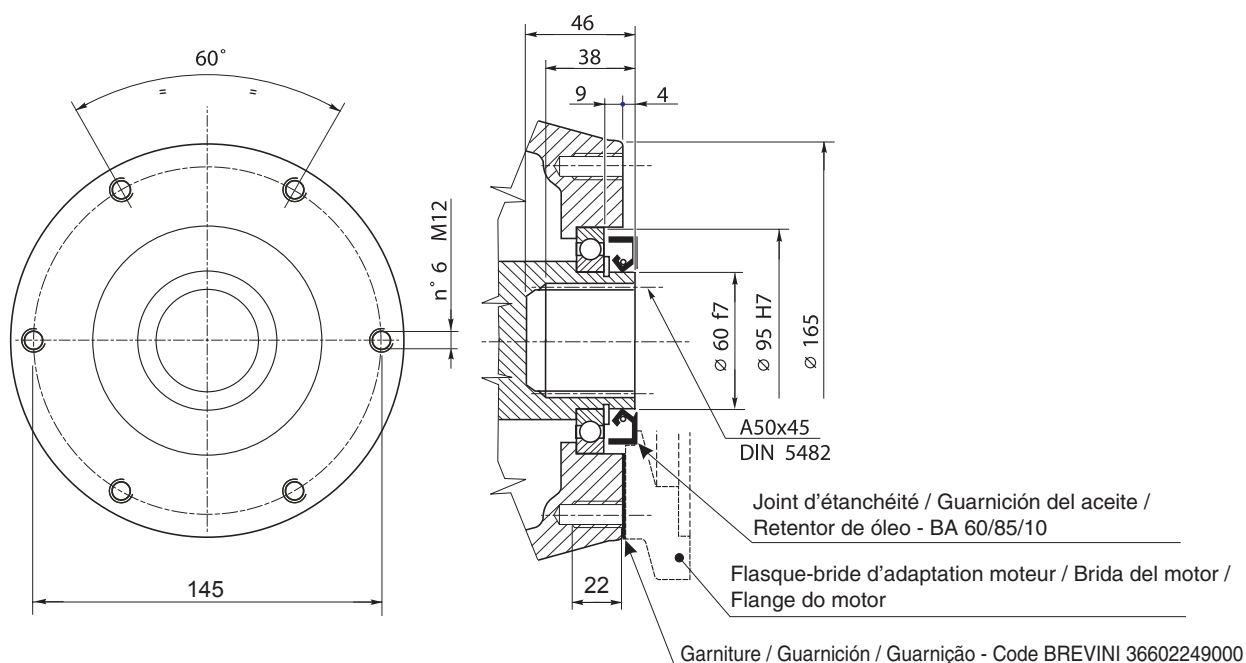

00

Pour frein / Por freno / Por freno

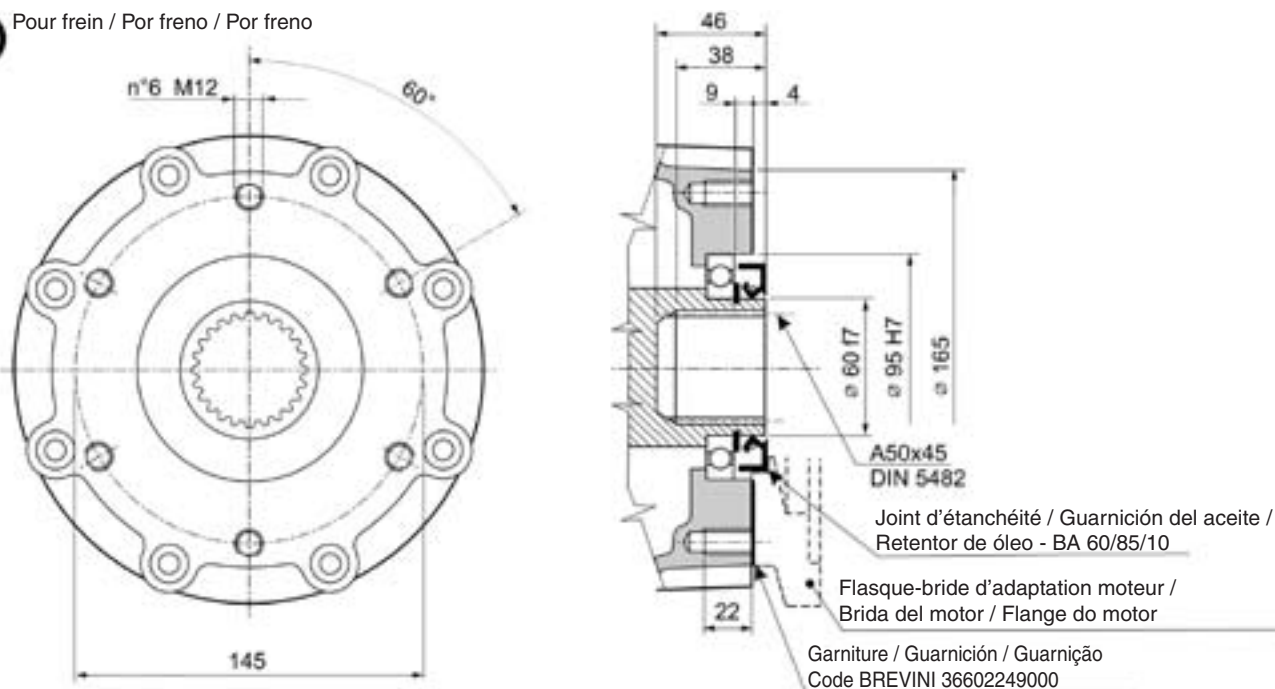

**12. FLANGIATURA  
MOTORI  
SAE J 744C - NEMA**

**12. ADAPTORS  
FOR MOTORS  
SAE J 744C - NEMA**

**12. ANFLANSCHEN  
DER MOTOREN  
SAE J 744C - NEMA**

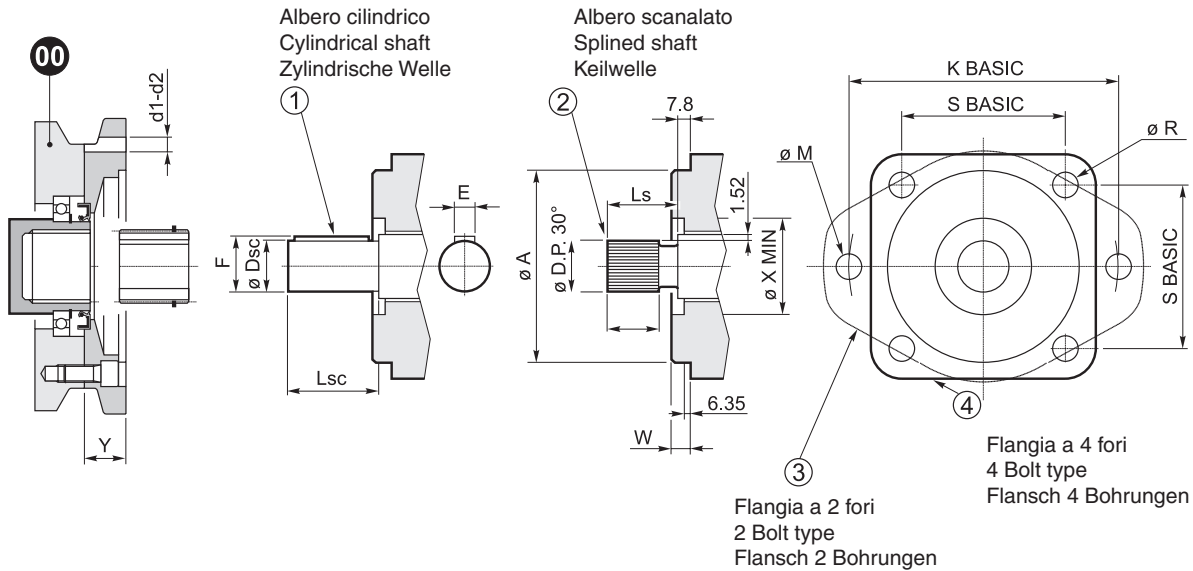

SAE	Ø A	W	Ø X MIN	K basic	Ø M	S basic	Ø R	ALBERO SCANALATO SPLINED SHAFT KEILWELLE				ALBERO CILINDRICO CYLINDRICAL SHAFT ZYLINDRISCHE WELLE			
								Nr.Denti No.Teeth Anz. Zähne	30° D.P.	LS	LA MIN.	Ø DSC	LSC	F	E
A	82.55	6.35	—	106.4	13	75.22	—	9	16/32	24	7.6	15.88	24	17.6	4
B	101.6	9.65	50.8	146	14.3	89.8	14.3	13	16/32	33.3	10.2	22.22	33.3	24.95	6.35
B-B	101.6	9.65	50.8	146	14.3	89.8	14.3	15	16/32	38.1	12.7	25.4	38.1	28.1	6.35
C	127.0	12.7	63.5	181	17.5	114.5	14.3	14	12/24	47.6	15.2	31.75	47.6	35.2	7.8
C-C	127.0	12.7	63.5	181	17.5	114.5	14.3	17	12/24	54	17.8	38.1	54	42.25	9.525
D	152.4	12.7	70	228.6	20.6	161.6	20.6	13	8/16	66.67	20.3	44.45	66.67	49.3	11.1
E	165.1	15.87	70	317.5	27	224.5	20.6	13	8/16	66.67	20.3	44.45	66.67	49.3	11.1

## 12. FLASQUAGE AU MOTEURS SAE J 744C - NEMA

## 12. BRIDAS DE LOS MOTORES SAE J 744C - NEMA

## 12. FLANGES DE MOTORES SAE J 744C - NEMA

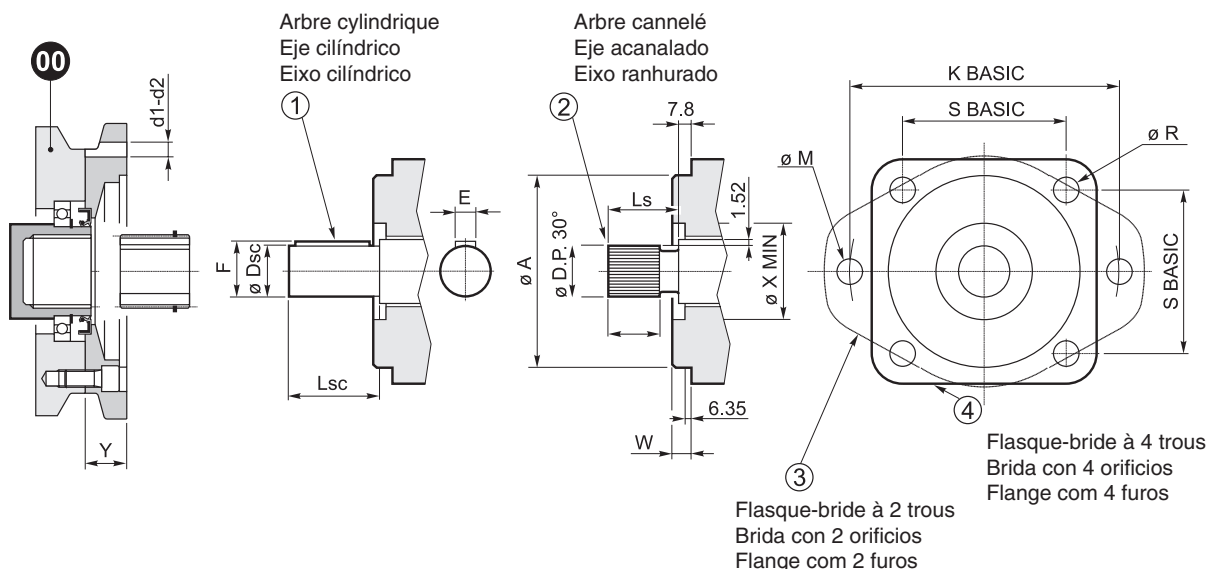

SAE	Ø A	W	Ø X MIN	K basic	Ø M	S basic	Ø R	ARBRE CANNELE EJE ACANALADO EIXO RANHURADO				ARBRE CYLINDRIQUE EJE CILÍNDRICO EIXO CILÍNDRICO			
								Nbre dents Dientes N.º dentes	30° D.P.	LS	LA MIN.	Ø DSC	LSC	F	E
A	82.55	6.35	—	106.4	13	75.22	—	9	16/32	24	7.6	15.88	24	17.6	4
B	101.6	9.65	50.8	146	14.3	89.8	14.3	13	16/32	33.3	10.2	22.22	33.3	24.95	6.35
B-B	101.6	9.65	50.8	146	14.3	89.8	14.3	15	16/32	38.1	12.7	25.4	38.1	28.1	6.35
C	127.0	12.7	63.5	181	17.5	114.5	14.3	14	12/24	47.6	15.2	31.75	47.6	35.2	7.8
C-C	127.0	12.7	63.5	181	17.5	114.5	14.3	17	12/24	54	17.8	38.1	54	42.25	9.525
D	152.4	12.7	70	228.6	20.6	161.6	20.6	13	8/16	66.67	20.3	44.45	66.67	49.3	11.1
E	165.1	15.87	70	317.5	27	224.5	20.6	13	8/16	66.67	20.3	44.45	66.67	49.3	11.1



SAE	Y	No. Bolt	CODICE DI ORDINAZIONE ORDERING CODE BESTELLNUMMER			CODICE DI ORDINAZIONE ORDERING CODE BESTELLNUMMER		
			Flangia con d1 / Flange with d1 / Flansch mit d1			Flangia con d2 / Flange with d2 / Flansch mit d2		
			d1 Metric Metrisch	Albero scanalato Splined shaft Keilwelle	Albero cilindrico Cylindrical shaft Zylindrische Welle	d2 Pollici Inch Zoll	Albero scanalato Splined shaft Keilwelle	Albero cilindrico Cylindrical shaft Zylindrische Welle
A	25	2 - 4	M10 T.U. 15	61125502680	61125500900	3/8 0.59 Min Full Thread	61147702680	61147700900
B	25	2 - 4	M12 T.U. 25	61125700580	61125700460	1/2 - 13 1.00 Min Full Thread	61143900580	61143900460
B-B	25	2 - 4	M12 T.U. 25	61125701940	61125700500	1/2 - 13 1.00 Min Full Thread	61143901940	61143900460
C	28	2	M16 T.U. 20	61101801480	61101800510	5/8-11 0.78 Min F.T.	61145301480	61145300510
		4	M14 T.U. 20			1/2-13 0.78 Min F.T.		
C-C	79	2	M16 T.U. 20	61101802540	61101801750	5/8-11 0.78 Min F.T.	61145302540	61145301750
		4	M14 T.U. 20			1/2-13 0.78 Min F.T.		
D	93	2 - 4	M18 T.U. 20	61103501930	61103501720	3/4 - 10 1.00 Min Full Thread	61147801930	61147801720
E	93	2 - 4	Æ 22 T.U. 30	61118201930	61118201720	Ø 0.875 1.11 Min	61118201930	61118201720

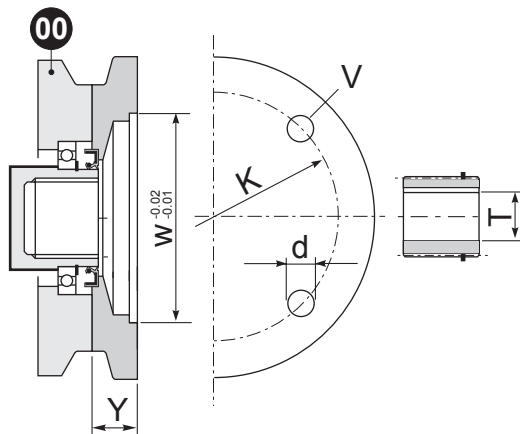

NEMA Grandezza motore Motor size Motorgröße	FLANGE ATTACCO MOTORE INPUT FLANGE ADAPTER MOTORANBAUFLANSCH					MANICOTTO COUPLING KUPPLUNG		CODICE DI ORDINAZIONE ORDERING CODE BESTELLNUMMER
	W	V	d	K	Y	T		
	Diametro Durchmesser	Linguetta Key Passfeder						
143/145 TD	9	4	0.55	10	1.18	0.875	0.187	61135501060
182/184 TC	8.5	4	0.55	7.25	1.18	1.125	0.25	61130800070
182/184 TD	9	4	0.55	10	1.18	1.25	0.25	61135502200
210 TD	9	4	0.55	10	1.18	1.375	0.312	61135502500
213/215 TC	8.5	4	0.55	7.25	1.81	1.375	0.312	61130802500

Dimensioni in pollici

Inch dimensions

Abmessungen in Zoll

Oltre alle flangiature riportate in tabella sono disponibili altri modelli a richiesta.

Most requested electric motor adapters are displayed. Other input flange and shaft adapters are available on request.

Neben den in der Tabelle aufgeführten Flanschadaptern sind weitere auf Anfrage erhältlich.

SAE	Y	No. Bolt	CODE DE COMMANDE CÓDIGO PARA EL PEDIDO CÓDIGO DE PEDIDO			CODE DE COMMANDE CÓDIGO PARA EL PEDIDO CÓDIGO DE PEDIDO		
			Flasque-bride avec d1 / Brida con d1 / Flange com d1			Flasque-bride avec d2 / Brida con d2 / Flange com d2		
			d1 Métrique Métrico Métrico	Arbre cannelé Eje acanalado Eixo ranhurado	Arbre cylindrique Eje cilíndrico Eixo cilíndrico	d2 Pouces Pulgadas Polegadas	Arbre cannelé Eje acanalado Eixo ranhurado	Arbre cylindrique Eje cilíndrico Eixo cilíndrico
A	25	2 - 4	M10 T.U. 15	61125502680	61125500900	3/8 0.59 Min Full Thread	61147702680	61147700900
B	25	2 - 4	M12 T.U. 25	61125700580	61125700460	1/2 - 13 1.00 Min Full Thread	61143900580	61143900460
B-B	25	2 - 4	M12 T.U. 25	61125701940	61125700500	1/2 - 13 1.00 Min Full Thread	61143901940	61143900460
C	28	2	M16 T.U. 20	61101801480	61101800510	5/8-11 0.78 Min F.T.	61145301480	61145300510
		4	M14 T.U. 20			1/2-13 0.78 Min F.T.		
C-C	79	2	M16 T.U. 20	61101802540	61101801750	5/8-11 0.78 Min F.T.	61145302540	61145301750
		4	M14 T.U. 20			1/2-13 0.78 Min F.T.		
D	93	2 - 4	M18 T.U. 20	61103501930	61103501720	3/4 - 10 1.00 Min Full Thread	61147801930	61147801720
E	93	2 - 4	Æ 22 T.U. 30	61118201930	61118201720	Ø 0.875 1.11 Min	61118201930	61118201720

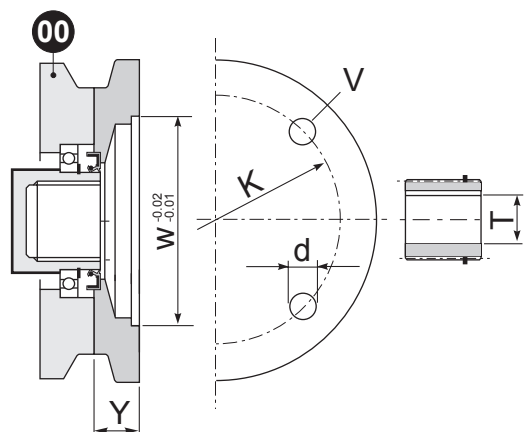

NEMA Grandeur moteur Tamaño del motor Tamanho do motor	FLASQUES-BRIDES POUR FIXATION SUR MOTEUR BRIDAS DEL MOTOR FLANGE ENGATE MOTOR					MANCHON OU MOYEU MANGUITO ACOPLAMENTO LUA ACOPLAMENTO		CODE DE COMMANDE CÓDIGO PARA EL PEDIDO CÓDIGO DE PEDIDO
	T					Diamètre Diámetro Diâmetro	Clavette Lengüeta Lingüeta	
	W	V	d	K	Y			
143/145 TD	9	4	0.55	10	1.18	0.875	0.187	61135501060
182/184 TC	8.5	4	0.55	7.25	1.18	1.125	0.25	61130800070
182/184 TD	9	4	0.55	10	1.18	1.25	0.25	61135502200
210 TD	9	4	0.55	10	1.18	1.375	0.312	61135502500
213/215 TC	8.5	4	0.55	7.25	1.81	1.375	0.312	61130802500

Dimensions en pouces

Dimensiones en pulgadas

Dimensões em polegadas

Aux flasques - brides indiquées dans le tableau viennent s'ajouter d'autres modèles sur demande.

Además de las bridas indicadas en la tabla, Brevini Riduttori puede suministrar diferentes modelos bajo pedido.

Além dos flanges indicados na tabela, estão disponíveis outros modelos a pedido.

### 13. STATO DI FORNITURA

I riduttori sono verniciati esternamente con fondo epossidico sintetico blu "RAL 5010", salvo di verse disposizioni contrattuali. La protezione è idonea a resistere a normali ambienti industriali anche esterni e consente ulteriori finiture con vernici sintetiche.

Nel caso si prevedano particolari condizioni ambientali aggressive, bisogna utilizzare delle verniciature speciali.

Le parti esterne lavorate del riduttore come le estremità degli alberi cavi e non, piani di appoggio, centraggi ecc. vengono protetti con olio (tectyl) antiossidante. Le parti interne delle carcasse dei riduttori sono verniciate con vernice antiolio e i cinematismi sono protetti con olio antiossidante.

**Tutti i riduttori**, salvo diverse indicazioni contrattuali, **vengono forniti senza lubrificazione**: come indicato da un'apposita etichetta adesiva allegata al riduttore stesso per evidenziarne lo stato.

I prodotti Brevini Riduttori S.p.A. vengono imballati e spediti, secondo i casi, in casse o su pallets.

Tutti i prodotti Brevini, salvo diverse indicazioni contrattuali, **vengono imballati con imballi idonei per resistere a normali ambienti industriali**.

Ogni riduttore Brevini viene fornito con specifico manuale di "Installazione e Manutenzione". Dichiarazione del fabbricante e l'attestato di Conformità – UNI EM10204-2.1.

### 14. CONDIZIONI DI STOCCAGGIO

Nel caso occorra immagazzinare il prodotto per un periodo superiore ai 2 mesi attenersi a quanto segue:

Proteggere gli alberi e i centraggi con pellicola di grasso e/o liquidi protettivi anticorrosione.

Riempire totalmente il riduttore e l'eventuale freno lamellare con oli adeguati.

Immagazzinare in luogo asciutto e con temperatura compresa fra i -5 °C e +30 °C.

Proteggere i colli dallo sporco, dalla polvere e dall'umidità.

Per immagazzinamento prolungato oltre i 6 mesi decade l'efficienza per le tenute rotanti. Si consiglia un controllo periodico facendo ruotare gli ingranaggi interni a mano ruotando l'albero in entrata, in presenza di freno lamellare negativo, bisogna sbloccare il freno, con pompa idraulica o similare (per pressione di apertura freno vedi capitolo freni). L'eventuale sostituzione all'atto del l'avviamento delle guarnizioni è consigliata.

### 13. SUPPLY CONDITION

The gear units are painted externally with synthetic primer in blue "RAL 5010", unless otherwise specified in the contract. The protection is suitable for withstanding normal industrial environments (also external) and can be finished with synthetic paints. If particular aggressive ambient conditions are foreseen, special painting is required.

The worked external parts of the gear unit, such as the ends of the hollow and solid shafts, support tables, centerings, etc., must be protected with antioxidant oil (tectyl). The parts inside the gear unit casings are painted with oil-proof paint and the kinematic mechanisms are protected with antioxidant oil. Unless otherwise specified in the contract, **all the gear units are supplied without lubrication**: as specified by a special sticker placed on the unit for indicating its condition.

Brevini Riduttori S.p.A. products are packed and shipped in boxes or on pallets, as required.

Unless otherwise specified in the contract, all Brevini products **are packed with packing suitable for withstanding normal industrial environments**.

Every Brevini gear unit comes with a specific "Installation and Maintenance" manual. Manufacturer's declaration and certificate of Conformity – UNI EM10204-2.1.

### 14. STORING CONDITIONS

If the product is to be stored for more than 2 months, carry out as follows:

Protect the shafts and centerings with a film of grease and/or anticorrosive protection liquids.

Completely fill the gear unit and possible multidisc brake with suitable oils.

Store in a dry place with temperature of between -5 °C and +30 °C.

Protect the packages from dirt, dust and damp.

When storing for more than 6 months the rotating seals will lose efficiency.

It is advisable to carry out a periodical check, manually turning the internal gears, turning the input shaft; with negative multidisc brake, release the brake, with hydraulic pump or similar (for brake release pressure see the chapter Brakes). Possible replacement of the gaskets on starting is advisable.

### 13. LIEFERBEDINGUNGEN

Die Außenseite der Getriebe ist mit Epoxidharz blau "RAL 5010" lackiert, soweit vertraglich nicht anders vereinbart. Der Schutz ist für normale Industrieumgebungen und Außenbereiche geeignet und gestattet zusätzliche Überlackierung mit Synthetiklacken. Bei Einsatz unter besonders aggressiven Umgebungsbedingungen müssen Speziallacke verwendet werden.

Die bearbeiteten Außenteile des Getriebes wie die Stümpfe der Hohlwellen und Wellen, Stützflächen, Zentrieransätze usw. werden mit einem Film oxidationshemmenden Öls (Tectyl) geschützt. Die Innenteile der Getriebegehäuse werden mit schmierölfesten Lacken lackiert und die Getriebe sind durch oxidationshemmendes Öl geschützt.

**Alle Getriebe**, soweit vertraglich nicht anders vereinbart, **werden ohne Schmieröl geliefert**: ein Aufkleber auf dem Getriebe weist auf den Zustand desselben hin.

Die Produkte Brevini Riduttori S.p.A. werden in Kisten oder auf Paletten geliefert und versandt.

Alle Produkte Brevini, soweit vertraglich nicht anders vereinbart, **werden in Verpackung geliefert, die für normale Industrieumgebungen ausreichend sind**. **Alle Getriebe Brevini sind mit einem spezifischen "Installations- und Wartungshandbuch"**, mit Herstellererklärung und Konformitätsbescheinigung – UNI EM10204-2.1 versehen.

### 14. LAGERBEDINGUNGEN

Gehen Sie bei einer Lagerung des Produktes für einen Zeitraum von mehr als 2 Monaten wie folgt vor:

Schützen Sie die Wellen und die Zentrieransätze mit einer dünnen Fettschicht und/oder Rostschutzmitteln.

Füllen Sie das Getriebe und die eventuelle Lamellenbremse ganz mit den empfohlenen Ölsorten. Lagern Sie die Getriebe an einem trockenen Ort mit einer Temperatur von -5 °C bis +30 °C.

Schützen Sie die Ware vor Schmutz, Staub und Feuchtigkeit.

Bei Lagerung von mehr als 6 Monaten verlieren die Wellendichtungen ihre Wirksamkeit. Überprüfen Sie regelmäßig die Getriebe, indem Sie die Zahnräder von Hand mithilfe der Antriebswelle drehen; sollte eine Lamellenbremse eingebaut sein, muss die Bremse mit einer Hydraulikpumpe oder ähnlichem freigesetzt werden (für den Öffnungsdruck der Bremse siehe das Kapitel Bremsen). Bei der Inbetriebnahme sollte die Dichtung möglichst ersetzt werden.

### 13. ETAT DE LA FOURNITURE

Les réducteurs sont peints extérieurement par application d'un apprêt époxydique synthétique bleu "RAL 5010", sauf dispositions contractuelles contraires. La protection est prévue pour résister aux environnements industriels normaux, même extérieurs, et permet l'application de couches de finitions de peintures synthétiques. Dans le cas d'utilisation dans des particulières conditions d'ambiance agressives, il faut utiliser des peintures spéciales. Les parties extérieures usinées du réducteur, comme par exemple les bouts d'arbres creux et non, les plans d'appui, centrages, etc., doivent être protégés avec de l'huile (tectyl) antioxydante. Les parties intérieures des carcasses (autrement dit carters) des réducteurs sont revêtues d'une peinture anti-huile et les cinématismes sont protégés avec de l'huile antioxydante.

**Tous les réducteurs**, sauf dispositions contractuelles contraires, **sont livrés sans lubrification**: comme spécifié sur une étiquette autocollante jointe avec le réducteur pour signaler cette condition. Les produits Brevini Riduttori S.p.A. sont emballés et expédiés, suivant les cas, dans des caisses ou sur palettes. Tous les produits Brevini, sauf dispositions contractuelles contraires, **sont conditionnés dans des emballages prévus pour résister aux ambiances industrielles normales**.

**Chaque réducteur Brevini est accompagné d'un manuel d'Installation et d'Entretien spécifique. Déclaration du fabricant et certificat de conformité – UNI EM10204-2.1.**

### 14. CONDITIONS DE STOCKAGE

Dans le cas d'emménagement du produit pour une période de temps supérieure à 2 mois, respecter les points suivants: Protéger les arbres et les centrages avec un film de graisse et/ou de liquides de protection anticorrosion.

Remplir entièrement le réducteur et le frein à lamelles éventuelles avec des huiles appropriées.

Stocker en un lieu sec et avec une température comprise entre -5 °C et +30 °C. Protéger les colis contre la saleté, la poussière et l'humidité.

Pour le stockage au-delà des 6 mois, l'efficacité des joints rotatifs se dégrade. Il est conseillé d'effectuer un contrôle périodique en faisant tourner les engrenages internes à la main en tournant l'arbre en entrée; en présence d'un frein à lamelles négatif, il faut le débloquent le frein avec une pompe hydraulique ou un matériel similaire (pour la pression d'ouverture du frein, voir chapitre freins). Le remplacement éventuel, au moment du démarrage, des joints est conseillé.

### 13. CONFIGURACIÓN DE ENTREGA

Salvo cuando el contrato estipula lo contrario, los reductores están barnizados por fuera con una base epoxídica sintética azul "RAL 5010". Esta protección es idónea para instalaciones industriales bajo techo y a la intemperie y admite el acabado con barnices sintéticos. Si las condiciones ambientales son particularmente agresivas hay que utilizar barnices especiales.

Las partes externas mecanizadas del reductor (extremos de los ejes huecos y macizos, planos de apoyo, centrados, etc.) se protegen con aceite antioxidante (tectyl). Las carcassas de los reductores están barnizadas por dentro con barniz impermeable al aceite. Los mecanismos están protegidos con aceite antióxido.

**Salvo cuando el contrato** estipula lo contrario, todos los reductores Brevini se **entregan sin lubricantes**: así lo indica la descripción del estado que figura en la etiqueta adhesiva del reductor.

Los productos de Brevini Riduttori se envían embalados en cajones o en paletas, según los casos.

Salvo cuando el contrato estipula lo contrario, los productos Brevini **se los materiales de los embalajes son aptos para ambientes industriales normales. Cada reductor Brevini se entrega con un manual de instalación y mantenimiento. Declaración del fabricante y certificado de Conformidad – UNI EM10204-2.1.**

### 14. CONDICIONES DE ALMACENAJE

Si el producto debe permanecer almacenado más de dos meses:

Proteger los ejes y los centrages con una película de grasa o un líquido anticorrosión.

Llenar el reductor y eventualmente el freno laminar con aceites adecuados.

Almacenar en un sitio seco a una temperatura de -5 a +30 °C.

Proteger los bultos de la suciedad, el polvo y la humedad.

Si el almacenaje se prolonga más de seis meses las garniciones giratorias pierden eficiencia. Se aconseja revisarlas periódicamente girando a mano los engranajes interiores y el eje de entrada.

Si se observa freno negativo hay que desbloquear el freno con una bomba hidráulica o similar (la presión de apertura está indicada en el capítulo dedicado a los frenos) y sustituir las garniciones giratorias antes de utilizarlas por primera vez.

### 13. CONDIÇÃO DE FORNECIMENTO

Os reductores são pintados externamente com base epóxi sintética azul "RAL 5010", salvo disposições contratuais diferentes. A proteção é adequada para resistir a ambientes industriais normais, também externos, e permite acabamentos posteriores com tintas sintéticas.

Caso sejam previstas condições ambientais particularmente agressivas, será necessário utilizar tintas especiais.

As partes externas trabalhadas do reductor, como as extremidades dos eixos ocos e não ocos, planos de apoio, centragens, etc. são protegidas com óleo (tectyl) antioxidante. As partes internas das carcaças dos reductores são pintadas com tinta antióleo e os mecanismos cinemáticos são protegidos com óleo antioxidante.

**Todos os reductores**, salvo outra indicação contratual, **são fornecidos sem lubrificação**: como indicado em uma etiqueta adesiva apropriada fixada ao próprio reductor para evidenciar sua condição.

Os produtos Brevini Riduttori S.p.A. são embalados e expedidos, conforme os casos, em caixas ou sobre paletes. Todos os produtos Brevini, salvo indicações contratuais diferentes, **são embalados com embalagens idôneas para resistir a ambientes industriais normais**.

**Cada reductor Brevini é fornecido com um manual de "Instalação e manutenção" específico. Declaração do fabricante e atestado de Conformidade – UNI EM10204-2.1.**

### 14. CONDIÇÕES DE ARMAZENAGEM

Caso seja necessário armazenar o produto por um período superior a 2 meses, limitar-se ao que segue:

Proteger os eixos e as centragens com uma película de graxa e/ou líquidos de proteção anticorrosão Encher totalmente o reductor e o freio lamelar eventual com óleos adequados.

Armazenar em local seco e com temperatura entre -5 °C e +30 °C.

Proteger os volumes contra sujeira, poeira e umidade.

A eficiência dos retentores giratórios cai no caso de um armazenamento prolongado por mais de 6 meses. É aconselhável um controle periódico girando manualmente as engrenagens internas, girando o eixo na entrada; na presença de freio lamelar negativo, é necessário desbloquear o freio com bomba hidráulica ou similar (para a pressão de abertura do freio, consultar o capítulo Freios). É aconselhável a eventual substituição das garnições no momento da partida.

## 15. INSTALLAZIONE

L'installazione dei riduttori deve essere realizzata con cura e professionalità impiegando personale adeguatamente istruito e tecnicamente preparato.

La predisposizione al funzionamento deve avvenire rispettando tutte le indicazioni tecniche contenute rispettando tutte le indicazioni tecniche contenute nei relativi documenti.

Le strutture a cui vanno fissati devono essere rigide. con superfici di appoggio lavorate a macchina ben piane e prive di verniciatura, normali all'asse azionato, e con centraggi a tolleranza H8; Le superfici a contatto debbono essere preventivamente sgrassate in modo perfetto.

Deve essere curato l'allineamento tra il riduttore e l'albero da comandare, soprattutto nel caso di riduttori con uscita femmina scanalata che, ricordiamo, non accettano carichi esterni; Per il fissaggio devono essere impiegate viti di classe minimo 10.9 con serraggio al 75% dello snervamento.

Durante il montaggio debbono essere assolutamente evitati urti assiali violenti che potrebbero danneggiare i cuscinetti interni. Gli organi di comando da calettare sull'albero cilindrico in uscita devono essere lavorati come da indicazioni riportate nel capitolo: "Configurazioni uscite".

Quindi nel collegamento tra riduttore e motore si consiglia l'utilizzo di giunti in grado di recuperare disallineamento, mentre se si utilizzano organi meccanici non in grado di recuperare disallineamento, all'atto del montaggio porre molta attenzione all'allineamento fra riduttore e motore.

## 15. INSTALLATION

The gear units must be carefully installed by suitably trained technical personnel.

Preparation for operation must occur according to all technical information contained in relevant documents.

The structures to which they are fixed must be rigid, with perfectly flat machined unpainted support surfaces, normal with driven shaft, and with centerings to tolerance H8.

The contact surfaces must be duly and perfectly greased.

The unit must be carefully aligned with the driven shaft, especially with gear units with female splined output shaft which, it must be remembered, do not take external loads.

For fixing, use screws of class min. 10.9 with tightening at 75% yielding.

During assembly, violent axial impacts must absolutely be avoided since they could damage the internal bearings. The control parts to be fitted on the cylindrical output shaft must be worked according to the specifications given in the chapter: "Output configurations".

We are therefore recommending to use couplings that can recover misalignment when connecting gearbox and motor. In case of use of mechanical components that do not allow misalignment recovering, please pay special care to the alignment between gearbox and motor during assembling operations.

## 15. INSTALLATION

Die Installation der Getriebe muss sorgfältig und professionell durch technisch ausgebildete Fachkräfte ausgeführt werden.

Die Vorbereitung zur Inbetriebnahme muss entsprechend gemäß allen technischen Angaben der spezifischen Unterlagen.

Sie dürfen nur an starren Strukturen befestigt werden mit ebenen maschinenbearbeiteten unlackierten Auflageflächen, gewöhnlich an der angetriebenen Achse und mit Zentrieransätzen mit Toleranz H8;

Die Kontaktflächen müssen zuvor sorgfältig entfettet werden.

Die Ausrichtung zwischen Getriebe und angetriebener Welle ist äußerst sorgfältig vorzunehmen, besonders bei Hohlwellen mit Keilnut, die, wie bekannt ist, keinen externen Belastungen ausgesetzt werden dürfen;

Für die Befestigung sind Schrauben mit Mindestklasse 10.9 und Anziehmoment von 75% der Streckgrenze zu verwenden.

Bei der Montage sind unbedingt heftige Stöße gegen die Achsen zu vermeiden, durch die die inneren Lager beschädigt werden können.

Die Organe, die auf die zylindrische Abtriebswelle aufgezogen werden, müssen entsprechend den Anweisungen im Kapitel: "Konfigurationen Abtriebe" bearbeitet werden.

Wir empfehlen Motor und Getriebe durch Kupplungen zu verbinden, die die Fluchtabweichung aufheben können. Falls mechanische Teile ohne Beseitigung der Fluchtabweichung verwendet werden, muss bei der Montage die Ausrichtung zwischen Getriebe und Motor beachtet werden.

## 15. INSTALLATION

L'installation des réducteurs doit être effectuée par un professionnel qualifié et expressément habilité à réaliser cette opération.

La prédisposition au fonctionnement doit se faire en suivant toutes les indications techniques contenues dans les documents correspondants.

Les structures auxquelles sont fixés les réducteurs doivent être rigides, présentés des surfaces ou portées usinées parfaitement plane et nues (sans peinture), normales à l'arbre entraîné et des centrages avec une tolérance H8;

Les surfaces de contact doivent être préalablement dégraissées minutieusement.

Il faut prêter une attention particulière à l'alignement entre le réducteur et l'arbre à commander, notamment dans le cas de réducteurs avec sortie femelle cannelée qui, faut-il le rappeler, ne supportent pas de charges externes; Pour la fixation, il faut impérativement utiliser des vis de classe 10.9 minimum serrées à 75% de la limite d'élasticité.

Lors du montage, il faut absolument éviter tous chocs axiaux violents qui pourraient endommager les roulements internes.

Les organes de commande à assembler sur l'arbre cylindrique en sortie doivent être usinés en respectant les prescriptions indiquées dans le chapitre : "Configurations des sorties".

Pour le raccordement entre le réducteur et le moteur, on conseille donc d'utiliser des joints en mesure de récupérer le désalignement, alors que si on utilise des organes mécaniques pas en mesure de récupérer le désalignement, au moment du montage faire très attention à l'alignement entre le réducteur et le moteur.

## 15. INSTALACIÓN

Los reductores deben ser instalados por técnicos profesionales competentes y expertos.

Al prepararlos para funcionar es preciso respetar todas las indicaciones técnicas contenidas en los relativos documentos. Fijar el reductor en estructuras rígidas con superficies de apoyo mecanizadas muy planas y sin barnizar, perpendiculares al eje accionado (tolerancia de centrado H8);

Antes de comenzar hay que desengrasar cuidadosamente las superficies de contacto.

Mantener el reductor bien alineado al eje sobre todo si la salida hembra es acanalada porque, como se recordará, estas salidas no aceptan cargas externas.

Los tornillos de fijación deben ser como mínimo de 10.9 y estar apretados al 75%.

Durante el montaje hay que evitar los choques axiales violentos porque pueden dañar los rodamientos interiores.

Los órganos de mando que se ensamblan en el eje cilíndrico de salida deben estar mecanizados como se describe en el capítulo "Configuración de las salidas".

Por ello, en la conexión entre el reductor y el motor se recomienda el uso de uniones capaces de recuperar desalineaciones, mientras que si se usan órganos mecánicos que no sean capaces de recuperar desalineaciones, durante el montaje prestar mucha atención a la alineación entre el reductor y el motor.

## 15. INSTALAÇÃO

A instalação dos redutores deve ser realizada com cuidado e profissionalismo, empregando pessoal instruído de forma adequada e tecnicamente preparado.

A predisposição para o funcionamento deve ser efetuada respeitando todas as indicações técnicas contidas nos relativos documentos.

As estruturas às quais serão fixados devem ser rígidas, com superfícies de apoio acabadas a máquina, bem planas e isentas de tinta, perpendiculares ao eixo accionado e com centragens de tolerância H8;

As superfícies de contato devem ser desengraxadas preventivamente de modo perfeito.

O alinhamento entre o redutor e o eixo a ser operado deve ser observado, sobretudo no caso de redutores com saída fêmea ranhurada que, lembramos, não aceitam cargas externas; Para a fixação devem ser empregados parafusos com classe mínima de 10.9 com aperto até 75% do limite elástico.

Durante a montagem devem ser absolutamente evitados os impactos axiais violentos que podem danificar os coxins internos.

Os órgãos de comando a serem alinhados ao eixo cilíndrico na saída devem ser trabalhados como indicado no capítulo: "Configurações de saída".

Portanto, na ligação entre o redutor e o motor, aconselha-se a utilizar um acoplamento que consiga compensar o desalinhamento. Por outro lado, se forem utilizados órgãos mecânicos não capazes de compensar o desalinhamento, na altura da montagem será preciso prestar muita atenção ao alinhamento entre o redutor e o motor.

### 16. BRACCIO DI REAZIONE

INDICAZIONI PER LA COSTRUZIONE E ANCORAGGIO DEL BRACCIO DI REAZIONE

### 16. TORQUE ARM

INSTRUCTIONS FOR TORQUE ARM CONSTRUCTION AND ANCHORING

### 16. SCHUBSTREBE

ANWEISUNGEN FÜR DEN BAU UND DIE MONTAGE DER SCHUBSTREBE

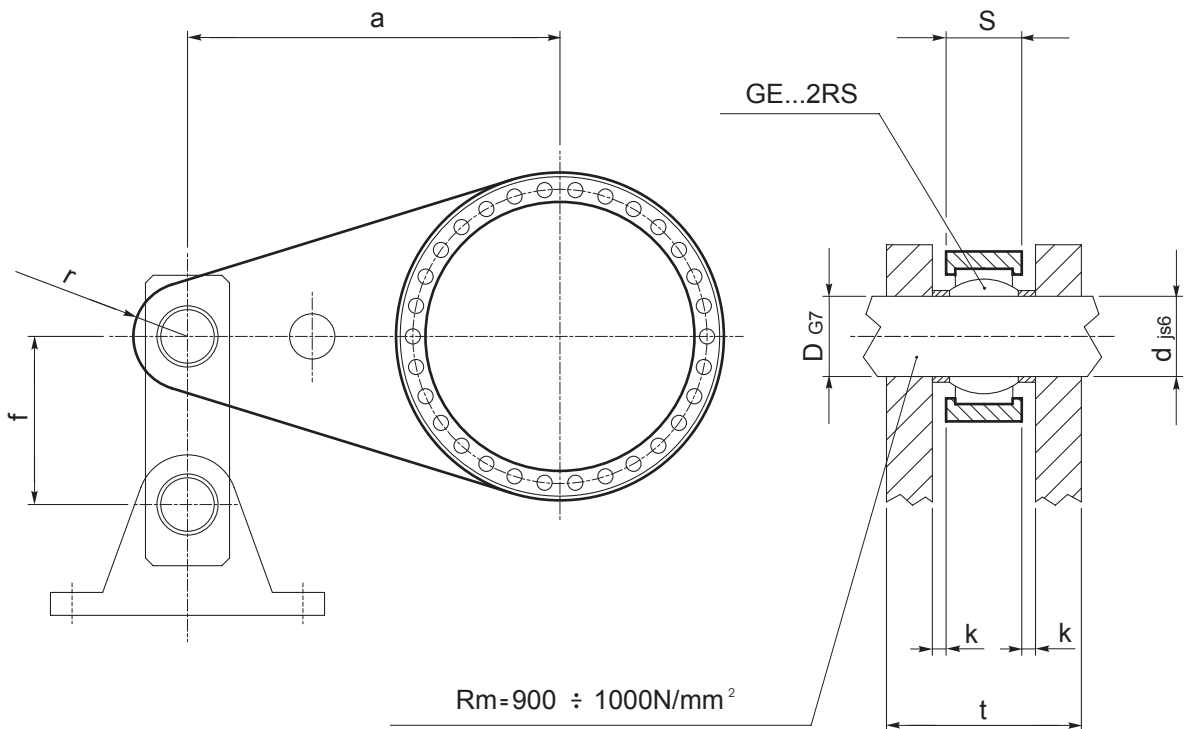

	a min [mm]	s [mm]	r min [mm]	f min [mm]	GE...2RS	D d [mm]	k [mm]	t min [mm]
010	200	15	20	80	20	20	2	35
020	300	15	20	80	20	20	2	35
030-045	300	20	25	100	25	25	3	46
065	400	20	25	100	25	25	3	46
090	500	25	30	150	30	30	3	55
150	600	25	30	150	30	30	3	55
250	700	30	35	150	35	35	4	66

### 16. BRAS DE RÉACTION

INSTRUCTIONS POUR LA CONSTRUCTION ET L'ANCRAGE DU BRAS DE REACTION

### 16. BRAZO DE REACCIÓN

INDICACIONES PARA FABRICAR Y ANCLAR EL BRAZO DE REACCIÓN

### 16. BRAÇO DE TORÇÃO

INDICAÇÕES PARA A CONSTRUÇÃO E ANCORAGEM DO BRAÇO DE TORÇÃO

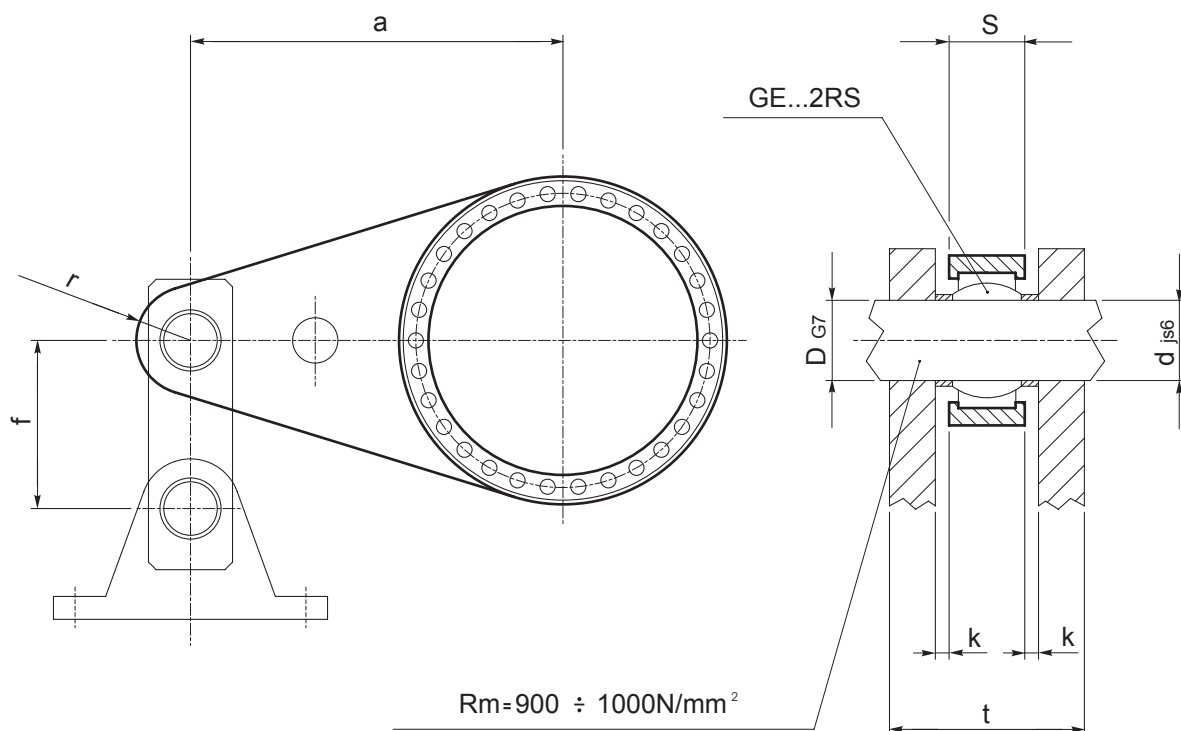

	a min [mm]	s [mm]	r min [mm]	f min [mm]	GE...2RS	D d [mm]	k [mm]	t min [mm]
010	200	15	20	80	20	20	2	35
020	300	15	20	80	20	20	2	35
030-045	300	20	25	100	25	25	3	46
065	400	20	25	100	25	25	3	46
090	500	25	30	150	30	30	3	55
150	600	25	30	150	30	30	3	55
250	700	30	35	150	35	35	4	66



## 17. LUBRIFICAZIONE

I riduttori Brevini vengono forniti privi di lubrificante; l'utilizzatore è tenuto ad effettuare il corretto riempimento prima della messa in moto della macchina.

### Caratteristiche fondamentali degli oli

I parametri importanti da considerare quando si sceglie il tipo di olio sono:

- la viscosità alle condizioni nominali di funzionamento
- gli additivi

Lo stesso olio, deve lubrificare sia i cuscinetti che gli ingranaggi e tutti questi componenti convivono all'interno della stessa scatola, in condizioni di funzionamento diverse. Consideriamo i singoli parametri.

### Viscosità

La viscosità nominale è riferita ad una temperatura di 40 °C, ma diminuisce velocemente all'aumentare della temperatura. Se la temperatura di funzionamento è compresa tra 50 °C e 70 °C, si può scegliere una viscosità nominale secondo la seguente tabella indicativa, scegliendo la viscosità più elevata quando si prevede la temperatura più alta.

$n_2$ [rpm]	50° C	70° C
$n_2 > 20$	<b>VG 150</b>	<b>VG 220</b>
$20 > n_2 > 5$	<b>VG 220</b>	<b>VG 320</b>
$n_2 > 5$	<b>VG 320</b>	<b>VG 460</b>

Particolare attenzione bisogna fare agli stadi in uscita molto caricati e con velocità molto basse (<1 giro/min). In questi casi bisogna ricorrere sempre ad oli con viscosità elevata e con una buona carica di additivazione Extreme Pressure (EP).

### Additivi

Oltre ai normali additivi antischiuma ed antiossidanti, è importante utilizzare oli lubrificanti con additivi in grado di conferire proprietà EP (extremepressure) ed anti-usura, secondo ISO 6743-6 L-CKC o DIN 51517-3 CLP. Chiaramente quindi occorre ricercare prodotti con caratteristiche EP tanto più forti (tipo MOBILGEAR SHC) quanto più lenta è la velocità del riduttore. È opportuno ricordare che, i composti chimici sostitutivi della lubrificazione idrodinamica, si formano a scapito della carica EP originale. Quindi, in presenza di velocità molto basse e carichi elevati, è importante rispettare gli intervalli di manutenzione per non deprimere eccessivamente le caratteristiche lubrificanti dell'olio.

## 17. LUBRICATION

Brevini gear units are supplied without lubricant; therefore the user must carry out correct filling before starting the machine.

### Fundamental characteristics of the oils

The important parameters to consider when choosing the type of oil are:

- viscosity at nominal operating conditions
- additives

The oil must lubricate the bearings and the gears and all these components work inside the same box, in different operating conditions. We will consider the individual parameters.

### Viscosity

Nominal viscosity is referred to a temperature of 40 °C, but rapidly decreases with an increase in temperature. If the operating temperature is between 50 °C and 70 °C, a nominal viscosity can be chosen according to the following guide table, choosing the highest viscosity if the highest temperature is foreseen.

## 17. SCHMIERUNG

Die Brevini - Getriebe werden ohne Schmieröl geliefert; der Benutzer muss dieselben vor der Inbetriebnahme der Maschine mit der vorschriftmäßigen Schmierölmenge füllen.

### Grundlegende schmieröleigenschaften

Bei der Schmierölauswahl sind die folgenden wichtige Parameter zu berücksichtigen:

- Viskosität bei Nennbetriebsbedingungen
- Additive

Dasselbe Öl muss sowohl Lager wie auch Zahnräder schmieren und diese Bauteile funktionieren zusammen in demselben Gehäuse unter unterschiedlichen Betriebsbedingungen. Nachfolgend werden die einzelnen Parameter kurz beschrieben.

### Viskosität

Die Nennviskosität bezieht sich auf eine Temperatur von 40 °C und nimmt mit der Zunahme der Temperatur rasch ab. Liegt die Betriebstemperatur zwischen 50 °C und 70 °C, kann eine Nennviskosität laut folgender Tabelle gewählt werden, wobei bei sehr hoher Temperatur die höchste Viskosität zu wählen ist.

Special attention must be paid to very loaded output stages and with very low speeds (<1 rpm). In such cases, always use high viscosity oils and with a good amount of Extreme Pressure (EP) additive.

### Additives

In addition to the normal antifoaming and antioxidant additives, it is important to use lubricating oils with additives that provide EP (extremepressure) and antiwear properties, according to ISO 6743-6 L-CKC or DIN 51517-3 CLP. Therefore it will be necessary to find products with EP characteristics all the stronger (type MOBILGEAR SHC) the slower the gear unit speed. It should be remembered that the chemical compounds replacing hydrodynamic lubrication are formed to the detriment of the original EP load. Therefore, with very low speeds and high loads it is important to respect the maintenance periods so as not to excessively diminish the lubricating characteristics of the oil.

Besonders vorsichtig muss man bei Abtriebsstufen unter hohen Lasten und mit niedriger Drehzahl (<1 U/min) sein. In diesen Fällen muss immer Schmieröl mit hoher Viskosität und einer ausreichenden Menge an E.P. Additiven eingesetzt werden.

### Additive

Neben den normalen Entschäumern und Oxidationshemmern müssen Schmieröle E.P. Additive (Extrem-Pressure) und verschleißhemmende Wirkstoffe laut ISO 6743-6 L-CKC oder DIN 51517-3 CLP enthalten. Es ist offensichtlich, dass dabei Produkte mit E.P. Eigenschaften (Typ MOBILGEAR SHC) zu wählen sind, die um so ausgeprägter sein müssen, je langsamer die Getriebedrehzahl ist. Es wird daran erinnert, dass sich die chemischen Substitutionsverbindungen der hydrodynamischen Schmierung zu Lasten des ursprünglichen EP-Gehalts bilden. Es ist daher bei sehr niedrigen Drehzahlen und hohen Belastungen sehr wichtig, dass die Wartungszeiträume zur Vermeidung einer übermäßigen Verschlechterung der Schmieröleigenschaften genau eingehalten werden.

## 17. LUBRIFICATION

Les réducteurs Brevini sont livrés sans lubrifiant; Il incombe à l'utilisateur d'effectuer le remplissage correct avant la mise en service de la machine.

### Caractéristiques fondamentales des lubrifiants

Les paramètres importants à considérer lors du choix du type de lubrifiant sont:

- la viscosité aux conditions nominales de fonctionnement
- les additifs ou dopes

La même huile doit pouvoir correctement lubrifier tant les roulements et que les engrenages et tous les composants renfermés dans le carter dans des conditions d'emploi différentes. Considérons à présent chacun des facteurs intervenant ici.

### Viscosité

La viscosité nominale se rapporte à une température de 40 °C, mais elle diminue rapidement lorsque la température du réducteur s'élève. Si la température de fonctionnement est comprise entre 50 °C et 70 °C, il sera alors possible de choisir une viscosité nominale selon le tableau suivant, en choisissant la viscosité la plus élevée lorsque l'on prévoit la température d'emploi la plus élevée.

$n_2$ [rpm]	50° C	70° C
$n_2 > 20$	<b>VG 150</b>	<b>VG 220</b>
$20 > n_2 > 5$	<b>VG 220</b>	<b>VG 320</b>
$n_2 > 5$	<b>VG 320</b>	<b>VG 460</b>

Il faut prêter une attention particulière aux étages en sortie très chargés et avec des vitesses très basses (<1 tr/min). Dans ces cas, il faut toujours recourir à des huiles avec une viscosité élevée et dopées EP extrême pression.

### Additifs ou dopes

En plus des additifs antimousse et anti-corrosion normaux, il est important d'utiliser d'autres huiles activées ou dopées [EP (extreme-pressure) et antiusure], selon la classification ISO 6743-6 L-CKC ou DIN 51517-3 CLP. Il est donc évident qu'il faut rechercher des produits dont les caractéristiques EP seront d'autant plus fortes (type MOBILGEAR SHC) que la vitesse de rotation du réducteur sera lente. Il est opportun de rappeler que: les composés chimiques de remplacement de la lubrification hydrodynamique se forment au détriment de la charge EP originale. En conséquence, dans le cas de vitesses très basses et de charges élevées, il est important de respecter les intervalles d'entretien pour éviter que les propriétés lubrifiantes de l'huile dégénèrent.

## 17. LUBRICACIÓN

Los reductores Brevini se entregan sin lubricante; el usuario debe rellenar el reductor antes de ponerlo en funcionamiento.

### Características fundamentales de los aceites

Los parámetros importantes a la hora de elegir un aceite son:

- la viscosidad en condiciones nominales de funcionamiento
- los aditivos.

El mismo aceite debe lubricar a los cojinetes y a los engranajes. Estos componentes coexisten dentro de la misma carcasa en condiciones de funcionamiento diferentes. Examinemos cada factor por separado.

### Viscosidad

La viscosidad nominal se mide por convención a 40 °C pero baja rápidamente si aumenta la temperatura. Si la temperatura de funcionamiento está entre 50 y 70 °C se puede elegir una viscosidad nominal en la siguiente tabla. Si existe la posibilidad de que la temperatura suba hay que elegir una viscosidad más alta.

## 17. LUBRIFICAÇÃO

Os redutores Brevini são fornecidos sem lubrificante; o usuário deve efetuar o abastecimento correto antes da colocação da máquina em funcionamento.

### Características fundamentais dos óleos

Os parâmetros importantes a serem considerados ao escolher o tipo de óleo são:

- a viscosidade nas condições nominais de funcionamento
- os aditivos

O próprio óleo, que deve lubrificar seja os coxins, seja as engrenagens e todos os componentes que convivem dentro da mesma caixa, em condições de funcionamento diferentes. Consideremos os parâmetros individuais.

### Viscosidade

A viscosidade nominal refere-se a uma temperatura de 40 °C, mas diminui rapidamente com o aumento da temperatura. Se a temperatura de funcionamento estiver entre 50 °C e 70 °C, será possível escolher uma viscosidade nominal conforme a seguinte tabela indicativa, escolhendo-se a viscosidade mais elevada quando for prevista a temperatura mais elevada.

Cuando la velocidad de rotación de salida es muy baja (<1 rpm) y la carga es muy grande hay que prestar mucha atención. En estos casos se debe recurrir a aceites con alta viscosidad y alto contenido de aditivos Extreme Pressure (EP).

### Aditivos

Además de los agentes antiespuma y antioxidantes convencionales, es importante que los aditivos añadan al lubricante propiedades EP (presión extrema) y antidesgaste, con arreglo a las normas ISO 6743-6 L-CKC o DIN 51517-3 CLP. Las características EP deben ser más marcadas cuanto más lenta es la velocidad del reductor. Recuerde que: los compuestos químicos que reemplazan a la lubricación hidrodinámica se forman a expensas de la carga EP original. Por tanto, si las velocidades son muy bajas y las cargas muy altas hay que respetar el programa de mantenimiento para que el aceite no se degrade demasiado.

Deve-se prestar atenção especial aos estágios de saída muito carregados e com velocidades muito baixas (<1 rotação/min). Nesses casos será necessário recorrer sempre a óleos com viscosidade elevada e com uma boa carga de aditivos do tipo Extreme Pressure (EP).

### Aditivos

Além dos aditivos normais antiespuma e antioxidante, é importante utilizar óleos lubrificantes com aditivos capazes de conferir propriedades EP (extrema pressão) e anti-desgaste, conforme as normas ISO 6743-6 LCKC ou DIN 51517-3 CLP. É necessário, portanto, procurar produtos com características EP tanto mais fortes (tipo MOBILGEAR SHC) quanto mais lenta for a velocidade do reductor. É oportuno lembrar que os compostos químicos substitutivos da lubrificação hidrodinâmica formam-se em detrimento da carga EP original. Dessa forma, na presença de velocidades muito baixas e cargas elevadas, será importante respeitar os intervalos de manutenção para não deteriorar excessivamente as características lubrificantes do óleo.

### Tipi di oli

Gli oli disponibili appartengono generalmente a tre grandi famiglie.

- 1) Oli minerali
- 2) Oli sintetici Poli-Alfa-Olefine
- 3) Oli sintetici Poli-Glicole

La scelta più appropriata è generalmente legata alle condizioni di impiego.

I riduttori non particolarmente caricati e con un ciclo di impiego discontinuo senza escursioni termiche importanti, possono certamente essere lubrificati con olio minerale.

Nei casi di impiego gravoso, quando i riduttori saranno prevedibilmente caricati molto ed in modo continuativo, con conseguente prevedibile innalzamento della temperatura, è bene utilizzare lubrificanti sintetici tipo polialfaolefine (PAO).

Gli oli di tipo poliglicole (PG) sono da utilizzare strettamente nel caso di applicazioni con forti strisciamenti fra i contatti, ad esempio nelle viti senza fine. Debbono essere impiegati con grande attenzione poiché non sono compatibili con gli altri oli e sono invece completamente miscibili con l'acqua. Questo fenomeno è particolarmente pericoloso poiché non si nota, ma deprime velocemente le caratteristiche lubrificanti dell'olio.

Oltre a questi già menzionati, ricordiamo che esistono gli oli idraulici e gli oli per l'industria alimentare.

I primi vengono usati per il comando dei freni negativi. Per una maggiore tutela dell'ambiente sottolineiamo l'esistenza di alcuni tipi biodegradabili.

I secondi trovano specifico impiego nell'industria alimentare in quanto sono prodotti speciali non nocivi alla salute.

Vari produttori forniscono oli appartenenti a tutte le famiglie con caratteristiche molto simili. Più avanti proponiamo una tabella comparativa tra le marche più note.

### Types of oils

The oils available generally belong to three big families.

- 1) Mineral oils
- 2) Poly-Alpha-Olefin synthetic oils
- 3) Poly-Glycol synthetic oils

The most suitable choice is generally tied to the conditions of use.

Gear units that are not particularly loaded and with a discontinuous operating cycle, without considerable temperature ranges, can certainly be lubricated with mineral oil.

In cases of heavy use, when the gear units are very loaded and in a continuous way, with resultant temperature increase, it is best to use polyalphaolefin synthetic lubricants (PAO).

Polyglycol oils (PG) are to be used strictly in the case of applications with heavy sliding between contacts, e.g. in worms. They must be employed with great care since they are not compatible with the other oils but are completely mixable with water. This phenomenon is particularly dangerous, since it is not noticed, but rapidly diminishes the lubricating characteristics of the oil.

In addition to the above, there are also hydraulic oils and oils for the food industry.

The former are used for the command of negative brakes. For better environmental protection there are several biodegradable types.

The latter have a specific use in the food industry since they are special products that are not harmful to the health.

Various producers supply oils belonging to all the families with very similar characteristics. A comparison table of the best known brands is given later on.

### Schmierösorten

Die verfügbaren Ösorten gehören allgemein zu drei großen Familien

- 1) Mineralöle
- 2) Synthetische Poly-Alpha-Olefin-Öle
- 3) Synthetische Polyglykolöle

Die Auswahl hängt im Allgemeinen von den Einsatzbedingungen ab.

Getriebe, die nicht im Dauerbetrieb laufen und keinen großen Belastungen und großen Temperaturschwankungen ausgesetzt sind, können problemlos mit Mineralölen geschmiert werden.

Bei Einsatz unter erschwerten Bedingungen, bei denen die Getriebe voraussichtlich hohen Lasten im Dauerbetrieb mit der entsprechenden voraussehbaren Temperaturerhöhung ausgesetzt sind, ist es angebracht, synthetische Poly-Alpha-Olefin-Öle (PAO) zu verwenden.

Die Poly-Glykolöle (PG) werden in Anwendungen benutzt, in denen starke Gleitreibungen zwischen den Kontaktflächen auftreten, wie z. B. in Schnecken. Bei ihrer Anwendung ist sehr sorgfältig vorzugehen, da sie mit anderen Schmierölen unverträglich, aber voll mit Wasser vermischtbar sind. Das ist besonders gefährlich, weil es unbemerkt erfolgt und sehr schnell die Schmiereigenschaften des Öls verschlechtert.

Neben den erwähnten Ölen gibt es noch Hydrauliköl und Öle für die Lebensmittelindustrie.

Die ersteren werden auf Negativbremsen eingesetzt. Zum Umweltschutz weisen wir auf einige biologisch abbaubare Ösorten hin.

Die zweiten werden von der Lebensmittelindustrie verwendet, da sie nicht gesundheitsschädlich sind.

Einige Hersteller liefern Schmieröle, die allen Familien mit sehr ähnlichen Merkmalen angehören. An anderer Stelle finden Sie eine Vergleichstabelle der bekanntesten Ölmarken.

### Types des huiles

Les huiles disponibles appartiennent généralement à trois grandes familles.

- 1) Huiles minérales
  - 2) Huiles synthétiques polyalphaoléfinés (PAO)
  - 3) Huiles synthétiques polyglycoles (PG)
- Le choix le plus adapté est généralement lié aux conditions d'emploi.

Les réducteurs assez peu chargés et avec un cycle de fonctionnement discontinu, sans variations de température importantes, peuvent certainement être lubrifiés à l'huile minérale.

Dans des conditions d'utilisation sévères, à savoir lorsque les engrenages sont très chargés et de manière continue, avec comme probable conséquence l'élévation de température, il convient d'utiliser des lubrifiants synthétiques type polyalphaoléfine (PAO). Les huiles de type polyglycoles (PG) conviennent particulièrement aux applications présentant d'importants frottements aux points de contact, comme par exemple dans les vis sans fin. Elles doivent être employées avec beaucoup de précautions, puisqu'elles ne sont pas compatibles avec les autres huiles et sont par contre totalement miscibles avec l'eau. Ce phénomène est d'autant plus dangereux qu'il n'est pas visible et dégrade rapidement les qualités de l'huile.

En sus de ces types déjà mentionnés, il est bon de rappeler qu'il existe des huiles hydrauliques et des huiles pour l'industrie alimentaire.

Les premiers sont employés pour la commande des freins négatifs. Il est bon d'indiquer ici l'existence de certains types biodégradables qui préservent le milieu naturel.

Les seconds conviennent à l'industrie alimentaire, car il s'agit de produits spéciaux qui ne sont pas nuisibles à la santé.

Noter que différents fabricants fournissent des huiles appartenant à toutes les familles avec des caractéristiques très similaires. Plus en avant, vous trouverez un tableau de comparaison des marques les plus connues.

### Tipos de aceites

Los aceites se agrupan en tres grandes familias.

- 1) Aceites minerales
- 2) Aceites sintéticos polialfaolefinas
- 3) Aceites sintéticos poliglicoles

El criterio de selección más adecuado toma en cuenta las condiciones de empleo.

Los reductores que no soportan una carga particularmente grande y se someten a ciclos de trabajo discontinuos sin variaciones icas significativas pueden utilizar un aceite mineral.

La carga de los reductores para usos severos suele ser muy grande y continua, por lo que la temperatura tiende a subir. En estos casos se recomienda utilizar polialfaolefinas (PAO).

Los poliglicoles (PG) se deben utilizar solamente cuando el rozamiento es intenso, como por ejemplo en los tornillos sin fin. Hay que manejarlos con precaución porque son completamente solubles en agua pero también incompatibles con otros aceites. Este fenómeno es imperceptible pero muy peligroso porque degrada rápidamente al lubricante.

Además de los mencionados, existen aceites hidráulicos y aceites especiales para la industria alimentaria.

Los primeros se utilizan para los frenos negativos. Los biodegradables contribuyen a proteger el medioambiente.

Los segundos se emplean en la industria de la alimentación porque no son nocivos para la salud.

Existen varios fabricantes que disponen de aceites con características similares en cada una de las familias. Más adelante se incluye una tabla comparativa de las marcas más conocidas.

### Tipos de óleo

Os óleos disponíveis pertencem geralmente a três grandes famílias.

- 1) Óleos minerais
- 2) Óleos sintéticos polialfaolefinas
- 3) Óleos sintéticos poliglicóis

A escolha mais apropriada é geralmente ligada às condições de emprego.

Os redutores não particularmente sujeitos a cargas elevadas e com um ciclo de trabalho descontínuo sem amplitudes térmicas relevantes podem certamente ser lubrificados com óleo mineral.

Nos casos de emprego rigoroso, quando os redutores forem provavelmente sujeitos a cargas muito elevadas e de modo contínuo, com o consequente e previsível aumento da temperatura, será melhor utilizar lubrificantes sintéticos do tipo polialfaolefinas (PAO). Os óleos de tipo poliglicóis (PG) devem ser utilizados especificamente no caso de aplicações com forte atrito entre os contatos, por exemplo, nos parafusos sem fim. Devem ser empregados com muita atenção porque não são compatíveis com os outros óleos e são, ao contrário, completamente misturáveis com a água. Esse fenômeno é particularmente perigoso porque não é observado, mas reduz rapidamente as características lubrificantes do óleo.

Além desses já mencionados, lembramos que existem os óleos hidráulicos e os óleos para a indústria alimentícia.

Os primeiros são usados para o comando dos freios negativos. Para uma maior proteção do meio ambiente, ressaltamos a existência de alguns tipos biodegradáveis.

Os últimos encontram emprego específico na indústria alimentícia pois são produtos especiais não nocivos à saúde.

Vários produtores fornecem óleos pertencentes a todas as famílias com características muito semelhantes. Mais adiante propomos uma tabela comparativa entre as marcas mais conhecidas.

**Contaminazione**

Durante il normale funzionamento, a causa del rodaggio delle superfici, è inevitabile che si trasferiscano nell'olio delle microparticelle metalliche. Questa contaminazione, può accorciare la vita dei cuscinetti, mandando in avaria prematura il riduttore. Per limitare e controllare il fenomeno, senza ricorrere a frequenti e costosi cambi d'olio, occorre prevedere l'impiego di un opportuno sistema ausiliario di circolazione dell'olio.

Con questo sistema, si ottiene il doppio vantaggio di controllare il livello di contaminazione con l'impiego di appositi filtri e di stabilizzare la temperatura di funzionamento al livello più adeguato per garantire la viscosità voluta. Infatti, può succedere che la capacità termica specifica del riduttore è insufficiente a garantire un livello di temperatura di funzionamento corretto e stabile. Vedremo più avanti i sistemi ausiliari disponibili presso la Brevini Riduttori.

Per problemi di lubrificazione di riduttori destinati a impieghi particolari sia per la tipologia costruttiva, sia per i parametri di funzionamento, è consigliabile contattare il servizio Tecnico-Commerciale Brevini.

A questo proposito ricordiamo che la Brevini Riduttori si avvale di un accordo tecnico con la Exxon Mobil in base al quale si può avere sia una consulenza preventiva mirata all'applicazione, sia il monitoraggio di applicazioni lubrificate con prodotti MOBIL.

**Contamination**

During normal operation, due to running-in of the surfaces, metallic microparticles will inevitably form in the oil. This contamination can shorten the life of the bearings, resulting in early breakdown of the gear unit. To limit and control this phenomenon, without resorting to frequent and costly oil changes, a suitable auxiliary oil circulating system must be provided.

This system offers the dual advantage of controlling the level of contamination with the use of special filters and stabilizing the operating temperature at a level more suitable for guaranteeing the required viscosity. In fact, the specific thermal capacity of the gear unit is sometimes insufficient to ensure a correct and stable operating temperature level. The auxiliary systems available from Brevini Riduttori will be described later on.

For lubrication problems with gear units intended for particular uses, for construction type and operating parameters, it is advisable to contact the Brevini Technical Commercial service.

In this respect, Brevini Riduttori has a technical agreement with Exxon Mobil for having preventive advice for the specific application, and the monitoring of applications lubricated with MOBIL products.

**Verschmutzung**

Während des normalen Betriebs entstehen durch den Abrieb der Oberflächen Mikrometallpartikel im Öl. Diese Verschmutzung kann die Lebensdauer der Lager verkürzen und zu einem Ausfall des Getriebes führen. Zur Einschränkung dieser Erscheinung ohne häufigen und kostspieligen Ölwechsel ist der Einbau einer zusätzlichen Filteranlage des Schmieröls empfehlenswert.

Diese Anlage bietet den doppelten Vorteil, einerseits den Grad der Ölverschmutzung zu reduzieren und andererseits die Betriebstemperatur auf einer für die gewünschte Viskosität geeigneten Temperaturstufe zu stabilisieren. Es kann mitunter der Fall eintreten, dass die spezifische Wärmeleistung des Getriebes nicht ausreicht, eine korrekte und stabile Stufe der Betriebstemperatur zu gewährleisten. An anderer Stelle werden die bei Brevini Riduttori verfügbaren Hilfssysteme beschrieben.

Wenden Sie sich bei Schmierproblemen von Getrieben, die sowohl bauseitig wie auch aufgrund der Betriebsparameter für besondere Anwendungen vorgesehen sind, direkt an die technische Verkaufsbearbeitung Brevini.

In diesem Zusammenhang dürfen wir erwähnen, dass Brevini Riduttori eine technische Vereinbarung mit Exxon Mobil abgeschlossen hat, die Ihnen eine gezielte Anwendungsberatung wie auch die Überwachung von Schmieranwendungen mit Produkten MOBIL ermöglicht.

### Contamination

Pendant le fonctionnement normal, à cause du rodage des surfaces, il est inévitable que des microparticules métalliques se transfèrent dans l'huile. Cette contamination peut diminuer la durée de vie des roulements et entraîner la défaillance prématurée du réducteur. Pour limiter et contrôler le phénomène, sans toutefois recourir à des renouvellements d'huile fréquents et onéreux, il faut prévoir l'emploi d'un système auxiliaire de circulation de l'huile.

Ce système présente le double avantage de pouvoir contrôler le niveau de contamination à l'aide de filtres spécifiques et de pouvoir stabiliser la température de fonctionnement au niveau le plus adapté pour garantir la viscosité voulue. En fait, il se peut que la puissance thermique spécifique du réducteur soit insuffisante à garantir un degré de température de fonctionnement correct et stable. Nous donnerons plus en avant les systèmes auxiliaires disponibles chez Brevini Riduttori.

Pour les problèmes de lubrification des réducteurs destinés à des applications particulières, tant pour le type de construction que pour les paramètres de fonctionnement, il est préférable de prendre contact avec le service technico-commercial Brevini.

A ce propos, il est bon de rappeler que Brevini Riduttori a conclu un accord technique avec Exxon Mobil pour permettre d'offrir un service à la fois de consultation préventive visée à l'application et de suivi (monitorage) d'applications lubrifiées avec des produits MOBIL.

### Contaminación

El rodaje de las superficies durante el funcionamiento normal hace que las micropartículas metálicas migren inevitablemente hacia el aceite. Este tipo de contaminación acorta la vida de los rodamientos y puede determinar una avería prematura del reductor. Para limitar el fenómeno, en lugar de recurrir a frecuentes y costosos cambios de aceite hay que instalar un circuito auxiliar de circulación.

Esta solución tiene dos ventajas: los filtros reducen la contaminación y la temperatura de funcionamiento se estabiliza en un valor que asegura la viscosidad necesaria. Puede suceder que la capacidad térmica específica del reductor no alcance a garantizar una temperatura de funcionamiento adecuada y estable. Más adelante se suministra la lista de sistemas auxiliares de la gama Brevini Riduttori.

Para resolver cualquier problema relacionado con la lubricación de reductores para usos especiales (construcción del circuito, ajuste, etc.) se aconseja contactar con el servicio técnico de Brevini Riduttori.

Se recuerda que Brevini Riduttori ha estipulado un acuerdo técnico con Exxon Mobil en virtud del cual el cliente puede adquirir asesoramiento para la futura aplicación o bien un servicio de monitoreo de las aplicaciones lubricadas con productos Mobil.

### Contaminação

Durante a operação normal, em função da lapidação das superfícies, é inevitável a transferência de micropartículas metálicas para a água. Essa contaminação pode reduzir a vida útil dos coxins, provocando a avaria prematura do redutor. Para limitar e controlar o fenômeno, sem recorrer a frequentes e custosas trocas de óleo, é necessário prever o emprego de um sistema auxiliar apropriado de circulação do óleo.

Com esse sistema se obtém uma dupla vantagem, de controlar o nível de contaminação com o emprego de filtros apropriados e estabilizar a temperatura de funcionamento ao nível mais adequado para garantir a viscosidade desejada. Efetivamente, a capacidade térmica específica do redutor pode ser insuficiente para garantir um nível de temperatura de funcionamento correto e estável. Veremos mais adiante os sistemas auxiliares disponíveis junto à Brevini Riduttori.

Para problemas de lubrificação de reductores destinados a empregos particulares, seja pelo tipo construtivo, seja pelos parâmetros de funcionamento, é aconselhável entrar em contato com o Serviço Técnico Comercial da Brevini.

A esse propósito, lembramos que a Brevini Riduttori se vale de um acordo técnico com a Exxon Mobil com base no qual é possível haver uma consultoria preventiva dirigida à aplicação e o monitoramento de aplicações lubrificadas com produtos MOBIL.

**Tabella oli lubrificanti per uso generale**

**Table of lubricant oils for general use**

**Tabelle der allaemein verwendeten Schmierole**

**Tableau des lubrifiants pour emoloi general**

**Tabla de aceites lubricantes para todos los usos**

**Tabela de óleos lubrificantes para uso geral**

Produttore Manufacturer Hersteller Marque Fabricante Produtor	Oli Minerali Mineral oils Mineralöle Huiles minérales Aceites minerales Óleos minerais			Oli Sintetici Polialfaolefine (PAO) Poly-Alpha-Olefin synthetic oils (PAO) Synthetische Poly-Alpha-Olefin-Öle (PAO) Huiles synthétiques polialphaoléfinas (PAO) Aceites sintéticos polialfaolefinas (PAO) Óleos sintéticos polialfaolefinas (PAO)			Oli Sintetici Poliglicoli (PG) Polyglycol synthetic oils (PG) Synthetische Polyglykölöle (PG) Huiles synthétiques polyglycoles (PG) Aceites sintéticos poliglicoles (PG) Óleos sintéticos poliglicóis (PAO)		
	ISO VG 150	ISO VG 220	ISO VG 320	ISO VG 150	ISO VG 220	ISO VG 320	ISO VG 150	ISO VG 220	ISO VG 320
<b>ADDINOL</b>	Transmission Oil CLP 150	Transmission Oil CLP 220	Transmission Oil CLP 320	Eco Gear 150 S	Eco Gear 220 S	Eco Gear 320 S	Luboil RS 150	Luboil RS 220	-
<b>AGIP</b>	Blasia 150	Blasia 220	Blasia 320	-	Blasia SX 220	Blasia SX 320	Blasia S 150	Blasia S 220	Blasia S 320
<b>ARAL</b>	Degol BG 150 Plus	Degol BG 220 Plus	Degol BG 320 Plus	Degol PAS 150	Degol PAS 220	Degol PAS 320	Degol GS 150	Degol GS 220	Degol GS 320
<b>BP</b>	Energol GR-XP 150	Energol GR-XP 220	Energol GR-XP 320	Energol EPX 150	Energol EPX 220	Energol EPX 320	Energol SG 150	Energol SG-XP 220	Energol SG-XP 320
<b>CASTROL</b>	Alpha SP 150	Alpha SP 220	Alpha SP 320	Alphasyn EP 150	Alphasyn EP 220	Alphasyn EP 320	Alphasyn PG 150	Alphasyn PG 220	Alphasyn PG 320
<b>CEPSA</b>	Engranajes HP 150	Engranajes HP 220	Engranajes HP 320	Engranajes HPX 150	Engranajes HPX 220	Engranajes HPX 320	Engranajes HPS 150	Engranajes HPS 220	Engranajes HPS 320
<b>CHEVRON</b>	Ultra Gear 150	Ultra Gear 220	Ultra Gear 320	Tegra Synthetic Gear 150	Tegra Synthetic Gear 220	Tegra Synthetic Gear 320	HiPerSYN 150	HiPerSYN 220	HiPerSYN 320
<b>DEA</b>	Falcon 150	Falcon 220	Falcon 320	Intor 150	Intor 220	Intor 20	Polydea 150	Polydea 220	Polydea 320
<b>ERG</b>	Roxin S EP 150	Roxin S EP 220	Roxin S EP 320	-	-	-	-	-	-
<b>ESSO</b>	Spartan EP 150	Spartan EP 220	Spartan EP 320	Spartan S EP 150	Spartan S EP 220	Spartan S EP 320	Glycolube 150	Glycolube 220	Glycolube 320
<b>FUCHS</b>	Renolin CKC 150	Renolin CKC 220	Renolin CKC 320	Renolin Unisyn CKC 150	Renolin Unisyn CKC 220	Renolin Unisyn CKC 320	Renolin PG 150	Renolin PG 220	Renolin PG 320
<b>LUBRITECH</b>	Gearmaster CLP 150	Gearmaster CLP 220	Gearmaster CLP 320	Gearmaster SYN 150	Gearmaster SYN 220	Gearmaster SYN 320	Gearmaster PGP 150	Gearmaster PGP 220	Gearmaster PGP 320
<b>KLÜBER</b>	Klüberoil GEM 1-150	Klüberoil GEM 1-220	Klüberoil GEM 1-320	Klübersynth EG 4-150	Klübersynth EG 4-220	Klübersynth EG 4-320	Klübersynth GH 6-150	Klübersynth GH 6-220	Klübersynth GH 6-320
<b>LUBMARINE</b>	Epona Z 150	Epona Z 220	Epona Z 320	-	Epona SA 220	Epona SA 320	-	-	-
<b>MOBIL</b>	Mobilgear XMP 150	Mobilgear XMP 220	Mobilgear XMP 320	Mobilgear SHC XMP 150	Mobilgear SHC XMP 220	Mobilgear SHC XMP 320	Glygoyle 22	Glygoyle 30	Glygoyle HE320
<b>MOLIKOTE</b>	L-0115	L-0122	L-0132	L-1115	L-1122	L-1132	-	-	-
<b>NILS</b>	Ripress EP 150	Ripress EP 220	Ripress EP 320	Ripress Synt Food 150	Ripress Synt Food 220	Ripress Synt Food 320	Ripress Synt 150	Ripress Synt 220	Ripress Synt 320
<b>OMV</b>	Gear HST 150	Gear HST 220	Gear HST 320	-	Gear SHG 220	Gear SHG 320	Gear PG 150	Gear PG 220	Gear PG 320
<b>OPTIMOL</b>	Optigear BM 150	Optigear BM 220	Optigear BM 320	Optigear Synthetic A 150	Optigear Synthetic A 220	Optigear Synthetic A 320	Optiflex A 150	Optiflex A 220	Optiflex A 320
<b>PAKELO</b>	Erolube EP-C ISO 150	Erolube EP-C ISO 220	Erolube EP-C ISO 320	Gearsint EP ISO 150	Gearsint EP ISO 220	Gearsint EP ISO 320	Allsint EP-C ISO 150	Allsint EP-C ISO 220	Allsint EP-C ISO 320
<b>PENNZOIL</b>	Super Maxol EP 150	Super Maxol EP 220	Super Maxol EP 320	-	-	-	-	-	-
<b>Q8</b>	Goya 150	Goya 220	Goya 320	El Greco 150	El Greco 220	El Greco 320	Gade 150	Gade 220	Gade 320
<b>ROLOIL</b>	EP/150	EP/220	EP/320	-	-	-	Sincat 150	Sincat 220	Sincat 320
<b>ROYAL PURPLE</b>	-	-	-	Synergy 150	Synergy 220	Synergy 320	-	-	-
<b>SHELL</b>	Omala 150	Omala 220	Omala 320	Omala HD 150	Omala HD 220	Omala HD 320	Tivela S 150	Tivela S 220	Tivela S 320
<b>SINCLAIR</b>	Warrior EP/ NL 150	Warrior EP/ NL 220	Warrior EP/ NL 320	-	-	-	-	-	-
<b>SUNOCO</b>	Sun EP 150	Sun EP 220	Sun EP 320	Duragear 150	Duragear 220	Duragear 320	-	-	-
<b>TAMOIL</b>	Carter EP Lubricant 150	Carter EP Lubricant 220	Carter Ep Lubricant 320	-	-	-	-	-	-
<b>TEXACO</b>	Meropa 150	Meropa 220	Meropa 320	Pinnacle EP 150	Pinnacle EP 220	Pinnacle EP 320	-	Synlube CLP 220	Synlube CLP 320
<b>TOTAL</b>	Carter EP 150	Carter EP 220	Carter EP 320	Carter SH 150	Carter SH 220	Carter SH 320	Carter SY 150	Carter SY 220	Carter SY 320
<b>TRIBOL</b>	1100/150	1100/220	1100/320	1510/150	1510/220	1510/320	800/150	800/220	800/320

**Tabella lubrificanti adatti per uso alimentare**

(approvati secondo specifiche USDA-H1 e NSF-H1)

**Tabelle dafür den Lebensmittelbereich geeigneten Schmieröle**

(zugelassen laut Normen USDA-H1 und NSF-H1)

**Tabla de aceites lubricantes aprobados para usos alimentarios**

(según especificaciones USDA-H1 y NSF-H1)

**Table of lubricants suitable for food use**

(approved according to USDA-H1 and NSF-H1 specifications)

**Tableau des lubrifiants pour usage alimentaire**

(approuvés selon les spécifications USDA-H1 et NSF-H1)

**Tabela de lubrificantes adequados para uso alimentar**

(aprovados conforme as especificações USDA-H1 e NSF-H1)

Produttore Manufacturer Hersteller Marque Fabricante Produtor	Oli Idrraulici Hydraulic oils Hydrauliköle Huiles hydrauliques Aceites hidráulicos Óleos hidráulicos			Oli per ingranaggi Gear oils Getriebeöle Huiles pour engrenages Aceites para engranajes Óleos para engranagens		
	ISO VG 32	ISO VG 46	ISO VG 68	ISO VG 150	ISO VG 220	ISO VG 320
<b>AGIP</b>	Rocol Foodlube Hi Power 32	-	-	Rocol Foodlube Hi-Torque 150	-	Rocol Foodlube Hi-Torque 320
<b>ARAL</b>	Eural Hyd 32	Eural Hyd 46	Eural Hyd 68	Eural Gear 150	Eural Gear 220	-
<b>BEL-RAY</b>	No-Tox HD Hyd Oil 32	No-Tox HD Hyd Oil 46	No-Tox HD Hyd Oil 68	No-Tox Syn Gear Oil 150	No-Tox Syn Gear Oil 220	No-Tox Syn Gear Oil 320
<b>BP</b>	Enerpar M 32	Enerpar M 46	Enerpar M 68	-	-	-
<b>CHEVRON</b>	Lubricating Oil FM 32	Lubricating Oil FM 46	Lubricating Oil FM 68	-	Lubricating Oil FM 220	-
<b>ESSO</b>	Nuto FG 32	Nuto FG 46	Nuto FG 68	-	Gear Oil FM 220	-
<b>KEYSTONE</b>	Nevastane SL 32	Nevastane SL 46	Nevastane SL 68	Nevastane EP 150	Nevastane EP 220	Nevastane EP 320
<b>KLÜBER</b>	Summit Hysyn FG 32	Summit Hysyn FG 46	Summit Hysyn FG 68	Klüberoil 4 UH1 N 150	Klüberoil 4 UH1 N 220	Klüberoil 4 UH1 N 320
<b>MOBIL</b>	DTE FM 32	DTE FM 46	DTE FM 68	DTE FM 150	DTE FM 220	DTE FM 320
<b>NILS</b>	Mizar 32	Mizar 46	Mizar 68	Ripress Synt Food 150	Ripress Synt Food 220	Ripress Synt Food 320
<b>OPTIMOL</b>	Optileb HY 32	Optileb HY 46	Optileb HY 68	Optileb GT 150	Optileb GT 220	Optileb GT 320
<b>PAKELO</b>	Non-Tox Oil Hydraulic ISO 32	Non-Tox Oil Hydraulic ISO 46	Non-Tox Oil Hydraulic ISO 68	Non-Tox Oil Gear EP ISO 150	Non-Tox Oil Gear EP ISO 150	Non-Tox Oil Gear EP ISO 150
<b>ROYAL PURPLE</b>	Poly-Guard FDA 32	Poly-Guard FDA 46	Poly-Guard FDA 68	Poly-Guard FDA 150	Poly-Guard FDA 220	Poly-Guard FDA 320
<b>SHELL</b>	Cassida Fluid HF 32	Cassida Fluid HF 46	Cassida Fluid HF 68	Cassida Fluid GL 150	Cassida Fluid GL 220	Cassida Fluid GL 320
<b>TEXACO</b>	Cygnus Hydraulic Oil 32	Cygnus Hydraulic Oil 32	Cygnus Hydraulic Oil 32	Cygnus Gear PAO 150	Cygnus Gear PAO 220	-
<b>TRIBOL</b>	Food Proof 1840/32	Food Proof 1840/ 46	Food Proof 1840/68	-	Food Proof 1810/220	Food Proof 1810/320



## 18.INDICAZIONI CONTROLLO OLI CON LUBRIFICAZIONE NON FORZATA

### Montaggio orizzontale Posizione livelli

Nel caso di montaggio orizzontale del riduttore, il normale livello per garantire una corretta lubrificazione è posto sulla mezzeria, Fig. (7). Per applicazioni con velocità di rotazione in uscita molto bassa ( $n_2 \leq 5$  rpm) è consigliabile fissare il livello ad una quota superiore di 50-100 mm. Fig. (8).

E' possibile verificare con facilità il corretto livello utilizzando un tubo trasparente posizionato come da figura.

Nel caso in cui la velocità di uscita sia estremamente bassa ( $n_2 \leq 1$  rpm), oppure se sono prevedibili lunghi periodi di fermo del riduttore, è consigliabile riempire tutta la scatola. In questo caso occorre prevedere l'impiego di un apposito serbatoio ausiliario (vedere il capitolo seguente).

Volendo montare uno strumento che consenta la verifica visiva del livello (o tramite apposito segnale elettrico), occorre eseguire un montaggio secondo lo schema Fig.(9). Montare il tappo di sfiato al di sopra dell'indicatore di livello tramite un tubo abbastanza lungo, collegando la parte superiore (vuota) del riduttore appena sotto allo sfiato. In questo modo si eviterà la fuoriuscita di olio.

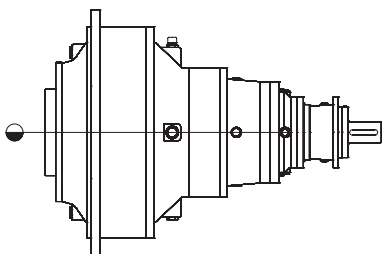

Fig. 7

## 18.INDICATIONS FOR OIL CONTROL DIAGRAMS WITHOUT AUXILIARY COOLING SYSTEM

### Horizontal mounting Position of levels

With horizontal mounting of the gear unit, the normal level for guaranteeing correct lubrication is located at the centre line. Fig. (7). For applications with very low output rotation speed ( $n_2 \leq 5$  rpm) it is advisable to fix the level at a value higher than 50-100 mm. Fig. (8).

The correct level can be easily checked using a transparent tube positioned as shown in the figure.

If the output speed is extremely low ( $n_2 \leq 1$  rpm), or if long gear unit downtimes are foreseen, it is advisable to fill the entire box. In this case a special auxiliary tank must be provided (see the next chapter).

To fit an instrument for visually checking the level (or by means of a special electric signal), assembly must be done according to the drawing in Fig. (9). Locate the breather plug over the instrument by mean of a long tube. Connect the upper (empty) part of the gearbox just under the breather by mean of a bleeding tube to prevent oil leakage.

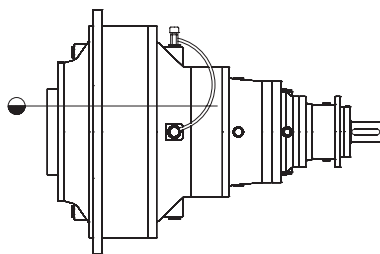

Fig. 8

## 18.HINWEISE FÜR DIE ÖLKONTROLLE OHNE DRUCKSCHMIERUNG

### Horizontale Einbaulage Füllstände

Bei horizontalem Getriebeeinbau liegt der normale Füllstand für eine störungsfreie Schmierung auf der Mittellinie, Abb. (7). Bei Anwendungen mit äußerst niedrigen Abtriebsdrehzahlen ( $n_2 \leq 5$  U/min) sollte der Füllstand um 50 - 100 mm höher liegen. Abb. (8).

Der vorschriftsmäßige Füllstand kann leicht mit einem durchsichtigen Schlauch kontrolliert werden (siehe Abbildung Bei extrem niedriger Abtriebsdrehzahl ( $n_2 \leq 1$  U/min) oder bei voraussichtlichen langen Stillstandzeiten des Getriebes ist es angebracht, das Gehäuse vollständig zu füllen. In diesem Fall ist ein besonderes Zusatzgefäß einzusetzen (siehe das folgende Kapitel).

Falls eine Sichtkontrolle des Ölstands (oder eine Kontrolle mittels eines elektrischen Signals) gewünscht wird, muss die Installation laut Schema der Abb. 9 vorgenommen werden. Die Entlüfterkappe auf dem Füllstandanzeiger mit einem ausreichend langen Schlauch montieren und den oberen (leeren) Teil des Getriebes knapp unter dem Entlüfter anschließen. Auf diese Weise wird das Austreten von Schmieröl verhindert.

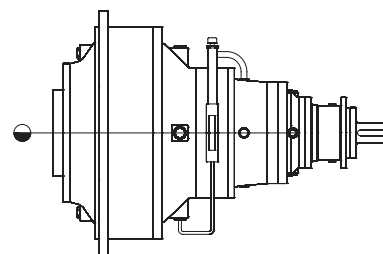

Fig. 9

## 18. INDICATIONS POUR LE CONTRÔLE DE L'HUILE AVEC UNE LUBRIFICATION PAR CIRCULATION NON FORCÉE

### Montage horizontal Position des niveaux

Dans le cas de montage du réducteur en position horizontale, le niveau d'huile pour une lubrification correcte doit se situer à mi-hauteur, Fig. (7). Pour les applications prévoyant une vitesse de rotation en sortie très basse ( $n_2 \leq 5$  tr/min), il est préférable de fixer le niveau à une cote supérieure à 50-100 mm. Fig. (8).

Pour vérifier facilement le niveau correct, utiliser un tube transparent positionné comme indiqué en figure.

Dans le cas de vitesse de sortie extrêmement basse ( $n_2 \leq 1$  tr/min) ou de longues périodes d'arrêt du réducteur, il est préférable de remplir tout le carter. Dans ce cas, il faut prévoir l'utilisation d'un réservoir auxiliaire prévu à cet effet (voir chapitre suivant).

Pour monter un indicateur permettant le contrôle visuel du niveau (ou par un signal électrique), il faut réaliser le montage selon le schéma Fig.(9).

Monter le bouchon reniflard au-dessus de l'indicateur de niveau en utilisant un tube assez long, en reliant la partie supérieure (vide) du réducteur juste en dessous du reniflard. Ceci pour éviter la sortie d'huile.

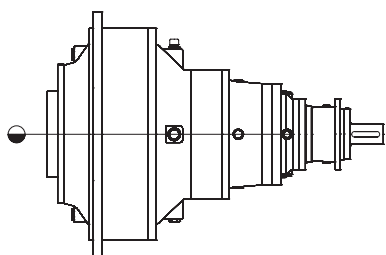

Fig. 7

## 18. INSPECCIÓN EN CASO DE LUBRICACIÓN NO FORZADA

### Montaje horizontal Posición de los niveles

En caso de montaje horizontal del reductor, el nivel indispensable para garantizar una buena lubricación coincide con la línea media, Fig. 7. En las aplicaciones en las que la velocidad de rotación de salida es muy baja ( $n_2 \leq 5$  rpm) el nivel se debe fijar 50 a 100 mm más arriba. Fig. (8).

El nivel se puede verificar fácilmente con la ayuda de un tubo transparente como se observa en la figura.

Si la velocidad de salida es extremadamente baja ( $n_2 \leq 1$  rpm) o el reductor debe atravesar largos periodos de inactividad, se aconseja llenar todo el depósito. Está prevista la instalación de un depósito auxiliar (véase el capítulo siguiente).

Si se desea montar un instrumento de verificación visual o eléctrica se aconseja aplicar el esquema de la Fig. 9. Colocar el tapón de purga por encima de la parte superior (vacía) del reductor inmediatamente debajo del orificio de purga. De esta forma se evitará que el aceite se derrame.

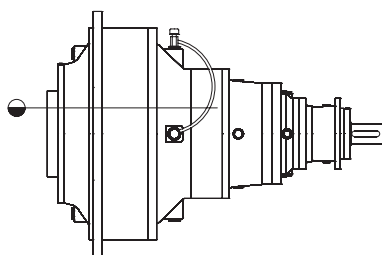

Fig. 8

## 18. INDICAÇÕES DE CONTROLE DE ÓLEO COM LUBRIFICAÇÃO NÃO FORÇADA

### Montagem horizontal Posição dos níveis

No caso de montagem horizontal do reductor, o nível normal para garantir uma lubrificação correta está colocado na linha central (fig. 7). Para aplicações com velocidades de rotação muito baixa na saída ( $n_2 \leq 5$  rpm) é aconselhável fixar o nível a uma quota superior de 50 a 100 mm. (Fig. 8).

É possível verificar com facilidade o nível correto utilizando um tubo transparente como mostrado na figura.

Caso a velocidade de saída seja extremamente baixa ( $n_2 \leq 1$  rpm), ou se forem previstos períodos longos de parada do reductor, será aconselhável encher toda a carcaça. Nesse caso, será necessário empregar um reservatório auxiliar apropriado (consultar o capítulo seguinte).

Desejando montar um instrumento que permita verificar visualmente o nível (ou através de um sinal elétrico apropriado), será necessário efetuar uma montagem segundo o esquema da fig. 9. Montar o bujão de respiro acima do indicador de nível através de um tubo comprido o suficiente, conectando a parte superior (vazia) do reductor imediatamente abaixo do respiro. Desse modo se evitará a saída de óleo.

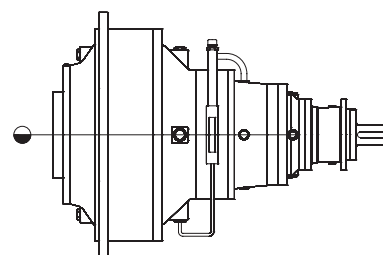

Fig. 9

**Vaso di espansione**

Nel caso di montaggio verticale e, comunque, ogni volta si renda necessario riempire completamente il riduttore, occorre rispettare alcune regole. All'atto del riempimento, nella parte superiore, in corrispondenza della tenuta rotante dell'albero di uscita, si può formare una bolla d'aria, che deve essere eliminata per evitare l'insufficiente lubrificazione della tenuta stessa. Inoltre sapendo che il volume dell'olio aumenta con la temperatura, occorre predisporre un serbatoio ausiliario che consenta all'olio di espandersi senza creare pericolose pressioni interne al riduttore.

**Expansion tank**

Several rules must be followed with vertical mounting, and in any case whenever the gear unit has to be completely filled. During filling, an air bubble can form in the upper part, at the output shaft revolving seal, and which must be eliminated in order to avoid insufficient lubrication of the seal. Also, since the volume of oil increases with the temperature, an auxiliary tank must be provided to allow the oil to expand without creating dangerous pressures inside the gear unit.

**Expansionsgefäß**

Bei vertikalem Einbau und in allen Fällen, in denen das Getriebe vollständig gefüllt werden muss, sind einige wichtige Regeln einzuhalten. Während des Füllens kann sich im oberen Teil in Höhe der Wellendichtung eine Luftblase bilden, die zur Vermeidung ungenügender Schmierung beseitigt werden muss. Da sich das Ölvolumen mit steigender Temperatur erhöht, muss ein Hilfsbehälter eingebaut werden, der die Ausdehnung des Öls ausgleicht und gefährliche Drücke im Inneren des Getriebes verhindert.

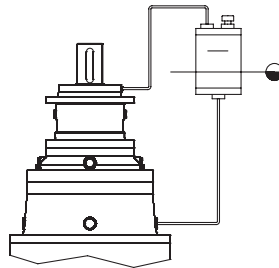

Fig. 10

Per il dimensionamento occorre determinare il volume (Ve) di espansione dell'olio alla temperatura di funzionamento:

For dimensioning, the oil expansion volume (Ve) at operating temperature must be determined:

Für die Bemessung des Behälters muss das Ausdehnungsvolumen (Ve) des Öls bei Betriebstemperatur berechnet werden:

$$V_e = V_t \times \Delta T / 1000$$

V<sub>t</sub> = volume totale dell'olio  
 ΔT = differenza tra temperatura di funzionamento e temperatura ambiente

V<sub>t</sub> = total volume of oil  
 ΔT = difference between operating temperature and ambient temperature

V<sub>t</sub> = Gesamte Ölmenge  
 ΔT = Unterschied zwischen Betriebs- und Umgebungstemperatur

La capacità (Vs) del vaso di espansione è:

The capacity (Vs) of the expansion tank is:

Das Aufnahmevermögen (Vs) des Expansionsbehälters ist:

$$V_s = 2 \times V_e$$

Per eliminare l'eventuale aria residua, devono essere collegati il foro presente nella zona più alta del riduttore e la parte superiore del vaso di espansione; quest'ultimo deve essere posto ad una altezza tale da garantire il pieno riempimento del riduttore al livello minimo. Si consiglia di realizzare il tubo di spurgo o lo stesso vaso di espansione con materiale trasparente, per poter verificare con facilità l'esatta posizione del livello del lubrificante.

To remove any residual air, the holes in the top part of the gear unit and the upper part of the expansion tank must be connected; the latter must be located at a height guaranteeing complete filling of the gear unit up to the minimum level. It is advisable to make the bleeding tube or the expansion tank with transparent material, to be able to easily check the exact position of the lubricant level.

Zur Entlüftung der Restluft ist die Bohrung im höchsten Teil des Getriebes mit dem Oberteil des Expansionsgefäßes zu verbinden; letzteres muss auf einer Höhe angeordnet werden, die gewährleistet, dass das Getriebe immer bis zum Mindeststand gefüllt ist. Es ist angebracht, einen Entlüftungsschlauch und ein Expansionsgefäß aus durchsichtigem Material zu verwenden, um jederzeit auf leichte Weise den Schmierölstand kontrollieren zu können.

### Vase d'expansion

Dans le cas de montage du réducteur en position verticale et, de toute façon, chaque fois qu'il est nécessaire de remplir complètement le réducteur, il faut respecter certaines règles.

Au moment du remplissage, dans la partie supérieure, au niveau du joint tournant de l'arbre de sortie, il peut se former une bulle d'air qui doit être éliminée pour éviter l'insuffisance de lubrification dudit joint. En outre, du fait que le volume de l'huile augmente avec la température, il faut prévoir un réservoir auxiliaire permettant à l'huile de se détendre sans créer des pressions dangereuses dans le réducteur.

### Depósito de expansión

En caso de montaje vertical y toda vez que se debe llenar el reductor, hay que respetar algunas reglas.

A la altura de la guarnición giratoria del eje de salida se puede formar al rellenar una burbuja de aire. Para que la guarnición quede bien lubricada hay que eliminarla. Como además el volumen del aceite aumenta con la temperatura, hay que instalar un depósito auxiliar para que la expansión del aceite no haga aumentar la presión dentro del reductor.

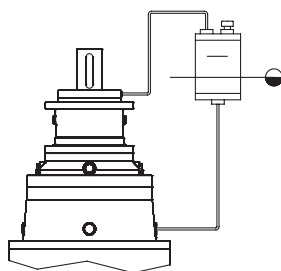

Fig. 10

### Vaso de expansão

No caso de montagem vertical e, de qualquer modo, toda vez que for necessário reabastecer completamente o reductor, será necessário respeitar algumas regras.

No ato do reabastecimento, na parte superior, em correspondência ao retentor giratório do eixo de saída, é possível a formação de uma bolha de ar, que deverá ser eliminada para evitar a lubrificação insuficiente do próprio retentor. Além disso, sabendo que o volume do óleo aumenta com a temperatura, será necessário colocar um reservatório auxiliar que permita a expansão do óleo sem criar pressões perigosas dentro do reductor.

Pour le dimensionnement, il faut déterminer le volume ( $V_e$ ) d'expansion de l'huile à la température de fonctionnement:

Para determinar el tamaño del depósito auxiliar hay que averiguar el volumen ( $V_e$ ) de expansión del aceite a la temperatura de funcionamiento:

Para o dimensionamento é necessário determinar o volume ( $V_e$ ) de expansão do óleo à temperatura de funcionamento:

$$V_e = V_t \times \Delta T / 1000$$

$V_t$  = volume total de l'huile

$\Delta T$  = différence ou écart température de fonctionnement et température ambiante

$V_t$  = volumen total de aceite

$\Delta T$  = diferencia entre la temperatura ambiente y la de funcionamiento

$V_t$  = volume total do óleo

$\Delta T$  = diferença entre a temperatura de funcionamento e a temperatura ambiente

La capacité ( $V_s$ ) du vase d'expansion est:

La capacidad ( $V_s$ ) del depósito de expansión es:

A capacidade ( $V_s$ ) do vaso de expansão é de:

$$V_s = 2 \times V_e$$

Pour éliminer l'air résiduel éventuel, l'orifice situé dans la partie la plus haute du réducteur et la partie supérieure du réservoir d'expansion doivent être reliés; ce dernier doit être situé à une hauteur suffisante pour garantir le remplissage du réducteur jusqu'au niveau minimum. Il est conseillé d'utiliser un tube de purge ou un vase d'expansion transparent, afin de faciliter l'examen visuel du niveau du lubrifiant.

Para eliminar el aire residual el agujero que está en la parte más alta del reductor se debe conectar con la parte superior del vaso de expansión, cuya altura debe a su vez permitir que el reductor se llene hasta el nivel mínimo. Se aconseja realizar el tubo de purga y el depósito de expansión en un material transparente para que sea más fácil inspeccionar el nivel.

Para eliminar o ar residual eventual, deverão ser conectados o furo presente na zona mais alta do reductor e a parte superior do vaso de expansão; este último deve ser colocado a uma altura tal que garanta o enchimento completo do reductor ao nível mínimo. É aconselhável realizar o tubo de expurgo ou o próprio vaso de expansão com material transparente, para poder verificar com facilidade a posição exata do nível do lubrificante.

### Montaggio verticale in linea e versioni ortogonali

I riduttori debbono essere completamente pieni, quindi occorre montare il vaso di espansione. Come detto in precedenza, è molto importante collegare lo sfiato superiore del riduttore al vaso di espansione per consentire all'olio di risalire fino all'anello di tenuta rotante dell'albero superiore del riduttore.

Volendo montare uno strumento che consenta la verifica visiva (o tramite apposito segnale elettrico), lo strumento sarà collocato sul fianco del serbatoio.

### Vertical mounting in-line and right-angle versions

The gear units must be completely full, then the expansion tank must be fitted. As already stated, it is very important to connect the top breather to the expansion tank in order to allow the oil to rise up to the rotating seal ring of the gear unit upper shaft.

To fit an instrument for visual checking (or by means of a special electric signal), the instrument must be placed on the side of the tank.

### Vertikaleinbau von In-Line- und Winkelgetrieben

Die Getriebe müssen vollständig gefüllt sein; daher ist immer ein Expansionsbehälter erforderlich. Wie bereits ausgeführt wurde, ist es sehr wichtig, dass die obere Entlüftung des Getriebes an das Expansionsgefäß angeschlossen wird, damit das Schmieröl die Wellendichtung der oberen Getriebewelle erreichen kann.

Falls eine Sichtkontrolle des Ölstands (oder eine Kontrolle mittels eines elektrischen Signals) gewünscht wird, muss das Gerät auf der Seite des Behälters angeordnet werden.

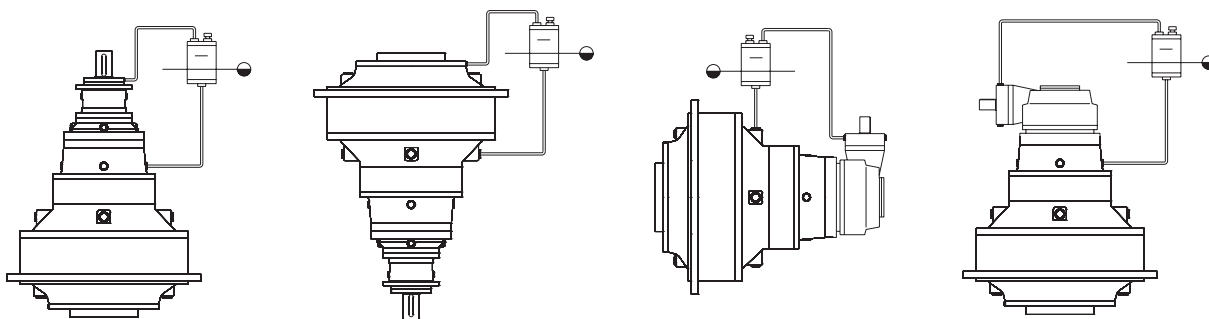

Fig. 11

### Sistemi ausiliari di raffreddamento e filtrazione

Nel caso la potenza trasmessa sia superiore alla potenza termica dissipabile dal riduttore, è necessario l'impiego di un sistema ausiliario di raffreddamento, in grado di smaltire la potenza termica in eccedenza e di mantenere anche un buon livello di pulizia dell'olio lubrificante, attraverso la filtrazione continua.

Per assolvere questa funzione, la Brevini Riduttori propone tre unità di raffreddamento in grado di dissipare rispettivamente 5, 10, 20 kW.

### Auxiliary cooling and filtering systems

If the power transmitted is higher than the thermal power that can be dissipated by the gear unit, an auxiliary cooling system able to dissipate the excess thermal power and also maintain a good level of cleaning of the lubricating oil through constant filtering, must be used.

To carry out this function, Brevini Riduttori proposes three cooling units able to dissipate 5, 10, 20 kW respectively.

### Zusätzliche kühl- und filteranlage

Falls die übertragene Leistung höher ist als die vom Getriebe abführbare Wärmeleistung muss ein zusätzliches Kühlsystem installiert werden, das in der Lage ist, die überschüssige Wärmeleistung abzuführen und durch Dauerfiltration das Schmieröl auf einem ausreichend sauberen Niveau zu halten.

Brevini Riduttori bietet zu diesem Zweck drei Kühleinheiten mit einer Wärmedissipation von jeweils 5, 10, 20 kW an.

### Montage vertical en ligne et versions orthogonales

Les réducteurs devant être complètement remplis, il faut donc monter le réservoir d'expansion. Ainsi qu'on l'a dit précédemment, il est très important de relier la purge supérieure du réducteur au vase d'expansion pour permettre à l'huile de remonter jusqu'au joint tournant de l'arbre supérieur du réducteur.

Si l'on veut monter un instrument permettant l'examen visuel (ou par signal électrique), celui-ci devra être placé à côté du réservoir.

### Montaje vertical en línea y versiones perpendiculares

Como los reductores deben estar completamente llenos, en ambos casos hay que montar el depósito de expansión. Es muy importante conectar la purga superior del reductor con el vaso de expansión para que el aceite suba hasta la guarnición giratoria del eje superior del reductor.

Si se desea montar un instrumento de verificación visual o eléctrica hay que colocarlo junto al depósito.

### Montagem vertical em linha e versões ortogonais

Os redutores devem ser completamente cheios e, assim, é necessário montar o vaso de expansão. Como mencionado anteriormente, é muito importante conectar o respiro superior do redutor no vaso de expansão para permitir a subida do óleo até o anel de retenção giratório do eixo superior do redutor.

Desejando montar um instrumento que permita uma verificação visual (ou através de um sinal elétrico apropriado), o instrumento será colocado ao lado do reservatório.

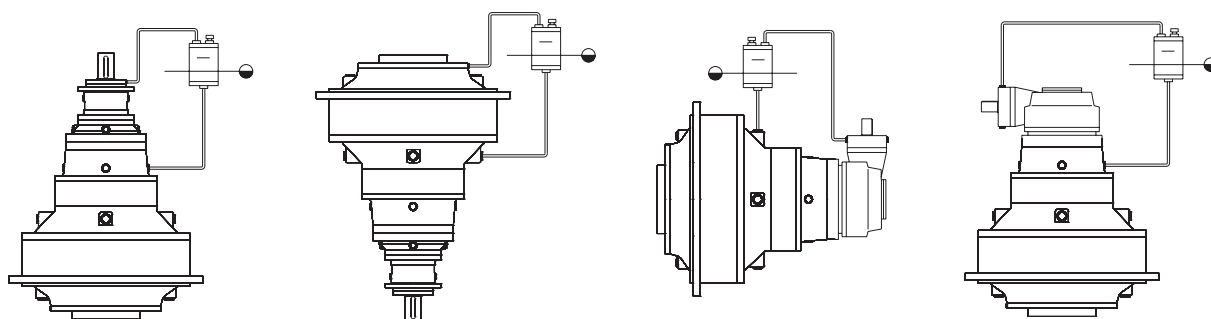

Fig. 11

### Systèmes auxiliaires de refroidissement et de filtration

Dans le cas où la puissance transmise est supérieure à la puissance thermique pouvant être dissipée par le réducteur, il faudra prévoir l'adoption d'un système auxiliaire de refroidissement capable d'évacuer la puissance thermique en excès et de maintenir également un bon degré de propreté du lubrifiant à travers une filtration continue.

Pour remplir cette fonction, Brevini Riduttori propose trois unités de refroidissement pouvant dissiper respectivement 5, 10, 20 kW.

### Sistemas auxiliares de enfriamiento y filtrado

Si la fuerza transmitida es mayor que la potencia térmica que puede disipar el reductor hay que instalar un sistema auxiliar de enfriamiento con filtrado continuo que elimine el exceso de temperatura y mantenga el aceite lubricante siempre limpio.

Brevini Riduttori fabrica tres unidades de enfriamiento opcionales que disipan 5, 10 y 20 kW respectivamente.

### Sistemas auxiliares de arrefecimento e filtragem

Caso a potência transmitida seja superior à potência térmica dissipável do reductor, será necessário empregar um sistema auxiliar de arrefecimento capaz de absorver a potência térmica em excesso e de também manter um bom nível de limpeza do óleo lubrificante através de uma filtragem contínua.

Para efetuar essa função, a Brevini Riduttori propõe três unidades de arrefecimento capazes de dissipar respectivamente 5, 10 e 20 kW.

19. Quantità olio [I]

19. Schmierung [I]

19. Volumen del aceite [I]

19. Oil quantity [I]

19. Quantité d'huile [I]

19. Quantidades de óleo [I]

Posizioni di montaggio / Mounting positions / Einbauposition / Positions de montage / Posiciones de montaje / Posições de montagem

1 B3  
B6  
B7  
B8

2 V5  
V6

3 V5A V6A B3D  
V5B V6B B6C  
V5C V6C B7A  
V5D V6D B8B

4 Type 1 2 3 4  
Type 1 2 3 4  
Type 1 2 3 4

Type	1	2	3	4
------	---	---	---	---

010

EM 1010	MN	0,5	1		
	MR	0,5	1		
	FE	0,5	1		
	FS	0,5	1		
ED 2010	MN	0,8	1,6		
	MR	0,8	1,6		
	FE	0,8	1,6		
	FS	0,8	1,6		
EC 2010	MN				
	MR				
	FE				
	FS				
ET 3010	MN	0,9	1,8		
	MR	0,9	1,8		
	FE	0,9	1,8		
	FS	0,9	1,8		
EC 3010	MN				
	MR				
	FE				
	FS				
EC 4010	MN				
	MR				
	FE				
	FS				
PD 1010	MR1	1,1	2		
PD 2010	MR1	1,3	2,3		
PD 3010	MR1	1,4	2,5		
PDA 2010	MR1				
PDA 3010	MR1				
PDA 4010	MR1				
<b>020</b>					
EM 1020	MR	1	2		
	FE	1,2	2,4		
	FS	1	2		
	FP				
ED 2020	MR	1,2	2,4		
	FE	1,5	3		
	FS	1,2	2,4		
	FP				
EC 2020	MR	2,2	4,4		
	FE	2,3	4,6		
	FS	2,2	4,4		
	FP				
ET 3020	MR	1,6	3,2		
	FE	1,7	3,4		
	FS	1,6	3,2		
	FP				

Type	1	2	3	4
------	---	---	---	---

020

EC 3020	MR				
	FE				
	FS				
	FP				
EQ 4020	MR	1,7	3,4		
	FE	1,8	3,6		
	FS	1,7	3,4		
	FP				
EC 4020	MR				
	FE				
	FS				
	FP				
PD 1020	MR1	3,6	6,8		
PD 2020	MR1	3,8	7,2		
PD 3020	MR1	4	7,5		
PD 4020	MR1	4,3	8		
PDA 2020	MR1				
PDA 3020	MR1				
<b>030</b>					
ED 2030	MR	1,3	2,6		
	FE	1,1	2,2		
	FS	1,3	2,6		
ET 3030	MR	1,6	3,2		
	FE	1,6	3,2		
	FS	1,6	3,2		
EC 3030	MR				
	FE				
	FS				
EQ 4030	MR	1,7	3,4		
	FE	1,7	3,4		
	FS	1,7	3,4		
EC 4030	MR				
	FE				
	FS				
PD 2030	MR1	3,6	6,8		
PD 3030	MR1	3,8	7,1		
PD 4030	MR1	4,1	7,6		
PDA 3030	MR1				
PDA 4030	MR1				
<b>040</b>					
ED 2040	MN	1,7	3,4		
ET 3040	MN	1,7	3,4		
EC 3040	MN				
EQ 4040	MN	1,8	3,6		
EC 4040	MN				

Type	1	2	3	4
------	---	---	---	---

045

EM 1045	MR	1	2		
	FE	1,1	2,2		
	FS	1	2		
	FP				
ED 2045	MR	1,6	3,2		
	FE	1,5	3		
	FS	1,6	3,2		
	FP				
EC 2045	MR	2	4		
	FE	2,1	4,2		
	FS	2	4		
	FP				
ET 3045	MR	1,6	3,2		
	FE	1,6	3,2		
	FS	1,6	3,2		
	FP				
EC 3045	MR	3	6		
	FE	3,2	6,4		
	FS	3	6		
	FP				
EQ 4045	MR	2,2	4,4		
	FE	2,5	5		
	FS	2,2	4,4		
	FP				
EC 4045	MR				
	FE				
	FS				
	FP				
PD 1045	MR1	3,4	6,5		
PD 2045	MR1	4	7,6	8,4	8,4
PD 3045	MR1	4,2	8	10,8	5,6
PD 4045	MR1	4,5	8,2		
PDA 2045	MR1	4	8	8,5	4,5
PDA 3045	MR1	5,5	7,5	11	6
PDA 4045	MR1				
<b>046</b>					
EM 1046	MN	1,2	2,4		
ED 2046	MN	2	4		
EC 2046	MN	2,5	5		
ET 3046	MN	1,8	3,6		
EC 3046	MN	3,3	6,6		
EQ 4046	MN	2,2	4,4		
EC 4046	MN				

Type ① ② ③ ④

065  
067

<b>EM 1065</b>	MN	1,6	3,2		
	FE	1,8	3,6		
	FS	1,6	3,2		
	FP				
<b>ED 2065</b>	MN	2,4	4,8		
	FE	2,6	5,2		
	FS	2,4	4,8		
	FP				
<b>EC 2065</b>	MN	2,7	5,4		
	FE	2,9	5,8		
	FS	2,7	5,4		
	FP				
<b>ET 3065</b>	MN	2,3	4,6		
	FE	2,5	5		
	FS	2,3	4,6		
	FP				
<b>EC 3065</b>	MN	3,7	7,4		
	FE	3,8	7,6		
	FS	3,7	7,4		
	FP				
<b>EQ 4065</b>	MN	2,5	5		
	FE	2,8	5,6		
	FS	2,5	5		
	FP				
<b>EC 4065</b>	MN				
	FE				
	FS				
	FP				
<b>PD 1065</b>	MR1	5	9		
<b>PD 2065</b>	MR1	5,8	10,5		
<b>PD 3065</b>	MR1	6	11		
<b>PD 4065</b>	MR1	6,4	11,8		
<b>PDA 2065</b>	MR1	6	11,4	12	6,5
<b>PDA 3065</b>	MR1	7	13,8	14	7,5
<b>PDA 4065</b>	MR1				

090  
091

<b>EM 1090</b>	MN	2,2	4,4		
	MR	3	6		
	FE	2,2	4,4		
	FS	2,2	4,4		
<b>ED 2090</b>	MN	2,2	4,4		
	MR	3,5	7		
	FE	3,2	6,4		
	FS	2,2	4,4		
<b>EC 2090</b>	MN	5	10		
	MR	6	12		
	FE	5,2	10,4		
	FS	5	10		
<b>ET 3090</b>	MN	3,3	6,6		
	MR	3,2	6,4		
	FE	3,2	6,4		
	FS	3,3	6,6		

Type ① ② ③ ④

090  
091

<b>EC 3090</b>	MN	5,2	10,4		
	MR	6,2	12,4		
	FE	5,5	11		
	FS	5,2	10,4		
	FP				
<b>EQ 4090</b>	MN	4	8		
	MR	5	10		
	FE	3,8	7,6		
	FS	4	8		
	FP				
<b>EC 4090</b>	MN	5,5	11		
	MR	6,5	13		
	FE	5,8	11,6		
	FS	5,5	11		
	FP				
<b>PD 1090</b>	MR1	5,2	9,5		
<b>PD 2090</b>	MR1	6	11		
<b>PD 3090</b>	MR1	6,3	11,6		
<b>PD 4090</b>	MR1	7	13		
<b>PDA 2090</b>	MR1	8,5	14,8	15	8
<b>PDA 3090</b>	MR1	9	15,4	15,5	8,5
<b>PDA 4090</b>	MR1	9,5	16	16	9

150  
155

<b>EM 1150</b>	MN	2,5	5		
	MR	4,5	9		
	FE	1,8	3,6		
	FS	2,5	5		
	FP				
<b>ED 2150</b>	MN	3,2	6,4		
	MR	5	10		
	FE	2,5	5		
	FS	3,2	6,4		
	FP				
<b>EC 2150</b>	MN	5	10		
	MR	7	14		
	FE	3	12		
	FS	5	10		
	FP				
<b>ET 3150</b>	MN	3,5	7		
	MR	5,3	10,6		
	FE	3	6		
	FS	3,5	7		
	FP				
<b>EC 3150</b>	MN	4,4	8,8		
	MR	6	12		
	FE	3,7	7,4		
	FS	4,4	8,8		
	FP				
<b>EQ 4150</b>	MN	3,7	7,4		
	MR	5,5	11		
	FE	3,5	7		
	FS	3,7	7,4		
	FP				
<b>EC 4150</b>	MN	5,5	11		
	MR	6	12		
	FE	3,5	7		
	FS	5,5	11		
	FP				

Type ① ② ③ ④

150  
155

<b>PD 1150</b>	MR1	5,5	10,2		
<b>PD 2150</b>	MR1	6,3	11,6		
<b>PD 3150</b>	MR1	6,5	12		
<b>PD 4150</b>	MR1	11	13,4		
<b>PDA 2150</b>	MR1	10	15,2	15,5	9
<b>PDA 3150</b>	MR1	9	15,7	16	9
<b>PDA 4150</b>	MR1	9	16,4	16,5	9,5

250  
255

<b>EM 1250</b>	MN	3,8	7		
	FE	2,5	5		
	FS	3,8	7		
	FP				
<b>ED 2250</b>	MN	4,5	9		
	FE	3,5	7		
	FS	4,5	9		
	FP				
<b>EC 2250</b>	MN	6,5	13		
	FE	5	10		
	FS	6,5	13		
	FP				
<b>ET 3250</b>	MN	5	10		
	FE	4,5	9		
	FS	5	10		
	FP				
<b>EC 3250</b>	MN	5,7	11,4		
	FE	6	12		
	FS	5,7	11,4		
	FP				
<b>EQ 4250</b>	MN	5,2	10,4		
	FE	4,8	9,6		
	FS	5,2	10,4		
	FP				
<b>EC 4250</b>	MN	7	14		
	FE	5,7	11,4		
	FS	7	14		
	FP				
<b>320</b>					
<b>ED 2320</b>	FE	3,5	7		
<b>ET 3320</b>	FE	4,5	9		



## 20.POSIZIONI DI MONTAGGIO

## 20.MOUNTING POSITIONS

## 20.EINBAUPOSITION

		Posizione orizzontale / Horizontal position / Waagerechte Stellung Position Horizontale / Posición Horizontal / Posição Horizontal		Posizione verticale / vertical position / Senkrechte Stellung Position Verticale / Posición Vertical / Posição Vertical	
		010-091	150-320	010-091	150-320
INLINE	MN-MR-MN1-MR1				
	FE				
	FS				

### RIGHT ANGLE

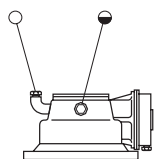

V5B

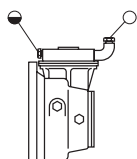

B3D

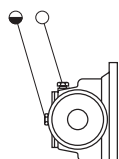

B3C

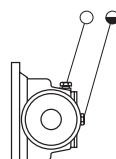

B3A

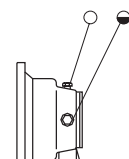

B3B

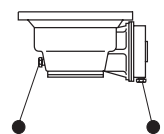

V6B

● Tappo scarico / Drain plug  
Bouchon de vidange de l'huile  
Ölablasstopfen  
Tapón vaciado aceite / Bujão de dreno

◐ Tappo livello / Oil level plug  
Bouchon de niveau de l'huile  
Ölstandsstopfen  
Tapón nivel aceite / Bujão de nível

○ Tappo carico e sfiato / Breather and filling plug  
Bouchon de remplissage de l'huile et reniflard  
Öleinfüll- und entlüftungstopfen  
Tapón llenado y presurizado  
Bujão de preenchimento e válvula de alívio

## 20.POSITIONS DE MONTAGE

## 20.POSICIONES DE MONTAJE

## 20.POSIÇÕES DE MONTAGEM

Posizione orizzontale / Horizontal position / Waagerechte Stellung  
Position Horizontale / Posición Horizontal / Posição Horizontal

Posizione verticale / vertical position  
Senkrechte Stellung / Position Verticale  
Posición Vertical / Posição Vertical

INLINE

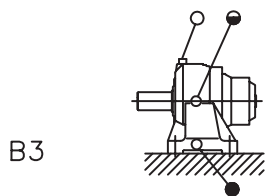

B3

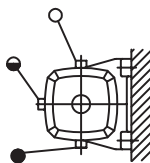

B7

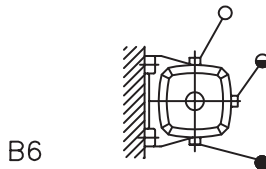

B6

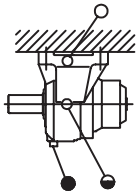

B8

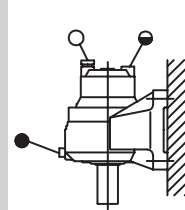

V5

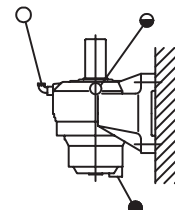

V6

RIGHT ANGLE

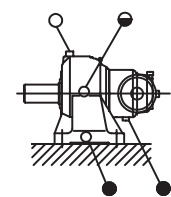

B3C

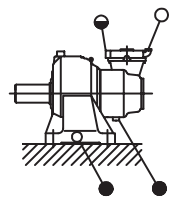

B3D

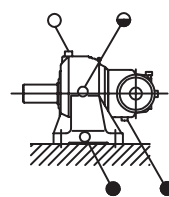

B3A

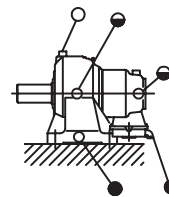

B3B

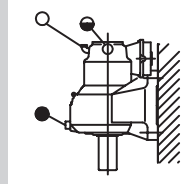

V5B

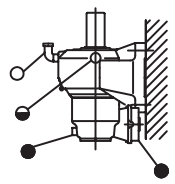

V6B

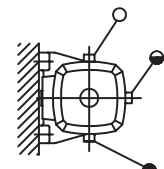

B6B

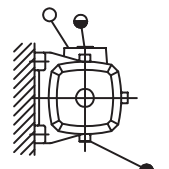

B6C

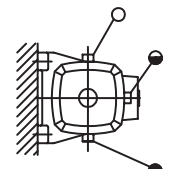

B6D

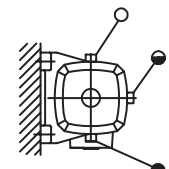

B6A

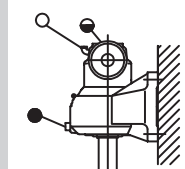

V5A

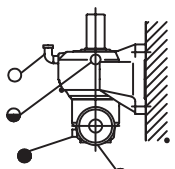

V6A

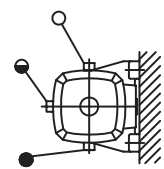

B7B

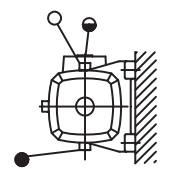

B7A

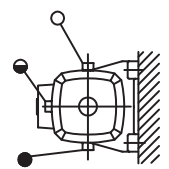

B7D

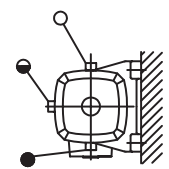

B7C

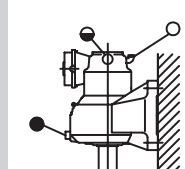

V5D

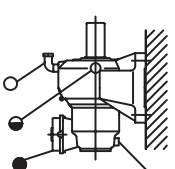

V6D

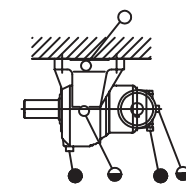

B8A

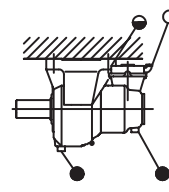

B8B

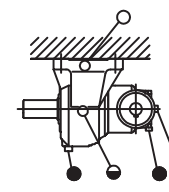

B8C

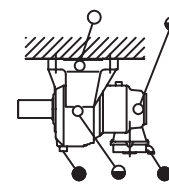

B8D

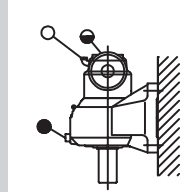

V5C

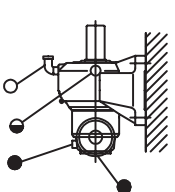

V6C